

International Energy Agency

Evaluation and Demonstration of Actual Energy Efficiency of Heat Pump Systems in Buildings (Annex 88)

State of the Art (Subtask A Report)

Energy in Buildings and Communities
Technology Collaboration Programme

October 2024

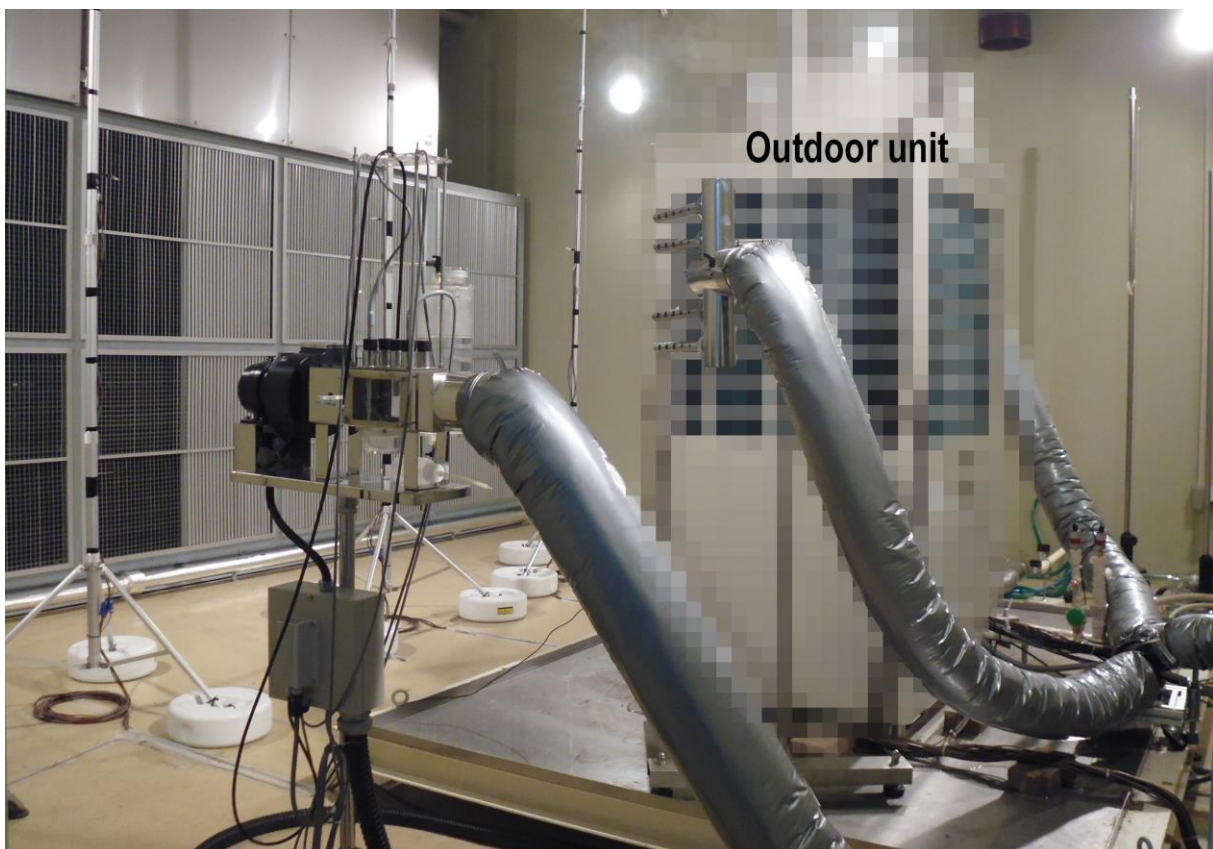

International Energy Agency

Evaluation and Demonstration of Actual Energy Efficiency of Heat Pump Systems in Buildings (Annex 88)

State of the Art (Subtask A Report)

Energy in Buildings and Communities
Technology Collaboration Programme

October 2024

Editors

Alberto Hernandez Neto, University of São Paulo, Brazil, (ahneto@usp.br)

Lu Aye, The University of Melbourne, Australia, (lua@unimelb.edu.au)

Takao Sawachi, Building Research Institute - National Research and Development Agency, Japan, (tsawachi@kenken.go.jp)

Main Authors

Akinori Hosoi, Japan Women's University, Japan, (hosoia@fc.jwu.ac.jp)

Alberto Hernandez Neto, University of São Paulo, Brazil, (ahneto@usp.br)

Alireza Afshari, Aalborg University, Denmark (aaf@build.aau.dk)

André Wachau, Federal Institute for Materials Research and Testing BAM, Germany, (andre.wachau@bam.de)

Baolong Wang, Tsinghua University, China, (wangbl@tsinghua.edu.cn)

Bruce Harley, Bruce Harley Energy Consulting LLC, United States, (bruce@bruceharleyenergy.com)

Christian Vering, RWTH Aachen University, Germany, (cvering@eonerc.rwth-aachen.de)

Dirk Müller, RWTH Aachen University, Germany, (dmueller@eonerc.rwth-aachen.de)

Jaap Hogeling, EPB Center, Netherlands, (jaap.hogeling@epb.center)

Jeremy Sager, Natural Resources Canada, Canada, (jeremy.sager@nrcan-rncan.gc.ca)

Kiyoshi Saito, Waseda University, Japan, (saito@waseda.jp)

Koji Kurotori, Tsukuba Building Research and Testing Laboratory, Center for Better Living, Japan, (kurotori@tbtl.org)

Laurent Social, Independent expert, Italy, (socal@iol.it)

Lu Aye, The University of Melbourne, Australia, (lua@unimelb.edu.au)

Napoleon Enteria, Mindanao State University, Philippines, (napoleon.enteria@g.msuiit.edu.ph)

Niccolo Giannetti, The University of Electro-Communications, Japan, (giannetti.n@gmail.com)

Shigeki Kametani, Osaka Metropolitan University, Japan, (kametani@omu.ac.jp)

Stephan Göbel, RWTH Aachen University, Germany, (stephan.goebel@eonerc.rwth-aachen.de)

Takao Sawachi, Building Research Institute - National Research and Development Agency, Japan, (tsawachi@kenken.go.jp)

Tetsutoshi Kan, Tsukuba Building Research and Testing Laboratory, Center for Better Living, Japan, (kan@tbtl.org)

Reviewers

Michele Zinzi, ENEA-TERIN-SEN, Italy

Søren Østergaard Jensen, Danish Energy Agency, Denmark

© Copyright Building Research Institute - National Research and Development Agency, Japan, 2024

All property rights, including copyright, are vested in Building Research Institute - National Research and Development Agency, Japan, Operating Agent for EBC Annex 88, on behalf of the Contracting Parties of the International Energy Agency (IEA) Implementing Agreement for a Programme of Research and Development on Energy in Buildings and Communities (EBC). In particular, no part of this publication may be reproduced, stored in a retrieval system or transmitted in any form or by any means, electronic, mechanical, photocopying, recording or otherwise, without the prior written permission of Building Research Institute - National Research and Development Agency, Japan.

Published by Building Research Institute - National Research and Development Agency, Japan, 1 Tachihara Tsukuba City, Ibaraki, Japan, 305-0802 as its Building Research Paper No. 152.

Disclaimer Notice: This publication has been compiled with reasonable skill and care. However, neither Building Research Institute - National Research and Development Agency, Japan], nor the Contracting Parties of the International Energy Agency's Implementing Agreement for a Programme of Research and Development on Energy in Buildings and Communities, nor their agents, make any representation as to the adequacy or accuracy of the information contained herein, or as to its suitability for any particular application, and accept no responsibility or liability arising out of the use of this publication. The information contained herein does not supersede the requirements given in any national codes, regulations or standards, and should not be regarded as a substitute for the need to obtain specific professional advice for any particular application. EBC is a Technology Collaboration Programme (TCP) of the IEA. Views, findings and publications of the EBC TCP do not necessarily represent the views or policies of the IEA Secretariat or of all its individual member countries.

The material described in Section 4.2.2.2 is reproduced from CSA Group standard CSA SPE-17:23, HVAC guide for Part 9 homes (CSA, 2023), clauses 0.1, 0.2, 0.3 and 1.0, with the permission of Canadian Standards Association, (operating as "CSA Group"),. This material is not the complete and official position of CSA Group on the referenced subject, which is represented solely by the Standard in its entirety. While use of the material has been authorised, CSA Group is not responsible for the way the data is presented, nor for any representations and interpretations. No further reproduction is permitted. For more information or to purchase standard(s) from CSA Group see (CSA, 2024b).

ISSN 0453-4972 (Building Research Paper, Building Research Institute – National Research and Development Agency, Japan)

Participating countries in the EBC TCP: Australia, Austria, Belgium, Brazil, Canada, P.R. China, Czech Republic, Denmark, Finland, France, Germany, Ireland, Italy, Japan, Republic of Korea, the Netherlands, New Zealand, Norway, Portugal, Singapore, Spain, Sweden, Switzerland, Turkey, United Kingdom and the United States of America.

Additional copies of this report may be obtained from: EBC Executive Committee Support Services Unit (ESSU), C/o AECOM Ltd, The Colmore Building, Colmore Circus Queensway, Birmingham B4 6AT, United Kingdom
www.iea-ebc.org
essu@iea-ebc.org

About IEA and Energy in Buildings and Communities Programme

The International Energy Agency

The International Energy Agency (IEA) was established in 1974 within the framework of the Organisation for Economic Co-operation and Development (OECD) to implement an international energy programme. A basic aim of the IEA is to foster international co-operation among the 31 IEA participating countries and to increase energy security through energy research, development and demonstration in the fields of technologies for energy efficiency and renewable energy sources.

The IEA Energy in Buildings and Communities Programme

The IEA co-ordinates international energy research and development (R&D) activities through a comprehensive portfolio of Technology Collaboration Programmes (TCPs). The mission of the IEA Energy in Buildings and Communities (IEA EBC) TCP is to support the acceleration of the transformation of the built environment towards more energy efficient and sustainable buildings and communities, by the development and dissemination of knowledge, technologies and processes and other solutions through international collaborative research and open innovation. (Until 2013, the IEA EBC Programme was known as the IEA Energy Conservation in Buildings and Community Systems Programme, ECBCS.)

The R&D strategy of the EBC TCP for the five-year period from 2024 to 2029 was derived from the IEA Future Building Forum Think Tank Workshop convened jointly with the other buildings-related IEA TCPs, as the members of the IEA Buildings Co-ordination Group and held in October 2022 in Gatineau, Canada, as well as the strategic planning workshop held at the EBC Executive Committee meeting in Istanbul, Türkiye in November 2022. To this end, four main themes form the basis of the EBC Strategic Plan 2024-2029, which are as follows:

- Collaboration with other related IEA TCPs
- Refreshing the priority research topics
- Achieving impact from EBC research activities
- Developing EBC governance

A series of actions have been agreed for each, as shown below.

Collaboration with Other Related IEA TCPs

- Introduce a process for evaluating, and if appropriate, proposing collaboration with other IEA TCPs as part of the review of proposals at the project concept stage to ensure early communication with other TCPs.
- Introduce a process by which Executive Committee members from the EBC TCP can work with Executive Committee members from other TCPs to propose fully collaborative projects.
- Introduce a process to scrutinise project concepts put forward to the Executive Committee to decide if they are more relevant to another TCP and should be directed accordingly.

Refreshing the Priority Research Topics

- The overall objective should follow the IEA 'Net Zero by 2050 – A Roadmap for the Global Energy Sector', with a demand-led approach that focuses on reduction in energy use and energy demand.
- Members countries should be asked to actively propose topics for research based on their priorities.
- In developed countries the overriding objective must be to address the retrofit of the existing building stock. Whilst in emerging economies more emphasis should be placed on delivering net-zero new buildings.
- Recognising the need to deliver energy security, avoid unnecessary infrastructure reinforcement, and alongside energy efficiency pay equal attention to demand management and flexibility to fully utilise fluctuating renewable energy supplies.
- Achieving performance in practice by closing the performance gap will be vital to delivering net zero greenhouse gas emissions by 2050.
- Ensuring that energy efficiency / decarbonisation measures in buildings are future-proof and ready for our 2050 climate.

Achieving impact from EBC research activities

- The main responsibility for delivering impact rests with each EBC project ('Annex').
- Encourage Annexes to engage early with stakeholders that facilitate the introduction of the developed technologies and processes to practising engineers, architects, designers and the market.

- During project planning, apply criteria for evaluating legal 'Annex Texts' that scrutinise their anticipated pathways to impact.
- Use 'theory of change' to identify relevant actors and their information needs for Annex outputs.
- Tailor outputs to the information needs and literacy of the relevant stakeholders, for example policy briefings should follow best practice guidance.
- Work with established channels for dissemination.

Developing EBC Governance

- Modernise the EBC Implementing Agreement (the overarching legal agreement), including introducing 'limited sponsors' with their benefits and obligations to be defined.
- Develop EBC policy on equality, diversity and inclusion.
- Reduce the number of running Annexes.
- Nominated Executive Committee members will review new project proposals and will be selective.
- Create platform for EBC Operating Agents (project managers for the Annexes) to share experience.
- Consider cost-shared proposals for funding Executive Committee agreed activities.

The Executive Committee

Overall control of the IEA EBC Programme is maintained by an Executive Committee, which not only monitors existing projects, but also identifies new strategic areas in which collaborative efforts may be beneficial. As the Programme is based on a contract with the IEA, the projects are legally established as Annexes to the IEA EBC Implementing Agreement. At the present time, the following projects have been initiated by the IEA EBC Executive Committee, with completed projects identified by (*) and joint projects with the IEA Solar Heating and Cooling Technology Collaboration Programme by (☼):

- Annex 1: Load Energy Determination of Buildings (*)
- Annex 2: Ekistics and Advanced Community Energy Systems (*)
- Annex 3: Energy Conservation in Residential Buildings (*)
- Annex 4: Glasgow Commercial Building Monitoring (*)
- Annex 5: Air Infiltration and Ventilation Centre
- Annex 6: Energy Systems and Design of Communities (*)
- Annex 7: Local Government Energy Planning (*)
- Annex 8: Inhabitants Behaviour with Regard to Ventilation (*)
- Annex 9: Minimum Ventilation Rates (*)
- Annex 10: Building HVAC System Simulation (*)
- Annex 11: Energy Auditing (*)
- Annex 12: Windows and Fenestration (*)
- Annex 13: Energy Management in Hospitals (*)
- Annex 14: Condensation and Energy (*)
- Annex 15: Energy Efficiency in Schools (*)
- Annex 16: BEMS 1- User Interfaces and System Integration (*)
- Annex 17: BEMS 2- Evaluation and Emulation Techniques (*)
- Annex 18: Demand Controlled Ventilation Systems (*)
- Annex 19: Low Slope Roof Systems (*)
- Annex 20: Air Flow Patterns within Buildings (*)
- Annex 21: Thermal Modelling (*)
- Annex 22: Energy Efficient Communities (*)
- Annex 23: Multi Zone Air Flow Modelling (COMIS) (*)
- Annex 24: Heat, Air and Moisture Transfer in Envelopes (*)
- Annex 25: Real time HVAC Simulation (*)
- Annex 26: Energy Efficient Ventilation of Large Enclosures (*)
- Annex 27: Evaluation and Demonstration of Domestic Ventilation Systems (*)
- Annex 28: Low Energy Cooling Systems (*)
- Annex 29: ☼ Daylight in Buildings (*)
- Annex 30: Bringing Simulation to Application (*)
- Annex 31: Energy-Related Environmental Impact of Buildings (*)
- Annex 32: Integral Building Envelope Performance Assessment (*)
- Annex 33: Advanced Local Energy Planning (*)
- Annex 34: Computer-Aided Evaluation of HVAC System Performance (*)
- Annex 35: Design of Energy Efficient Hybrid Ventilation (HYBVENT) (*)
- Annex 36: Retrofitting of Educational Buildings (*)

Annex 37: Low Exergy Systems for Heating and Cooling of Buildings (LowEx) (*)

Annex 38: ☼ Solar Sustainable Housing (*)

Annex 39: High Performance Insulation Systems (*)

Annex 40: Building Commissioning to Improve Energy Performance (*)

Annex 41: Whole Building Heat, Air and Moisture Response (MOIST-ENG) (*)

Annex 42: The Simulation of Building-Integrated Fuel Cell and Other Cogeneration Systems (FC+COGEN-SIM) (*)

Annex 43: ☼ Testing and Validation of Building Energy Simulation Tools (*)

Annex 44: Integrating Environmentally Responsive Elements in Buildings (*)

Annex 45: Energy Efficient Electric Lighting for Buildings (*)

Annex 46: Holistic Assessment Tool-kit on Energy Efficient Retrofit Measures for Government Buildings (EnERGo) (*)

Annex 47: Cost-Effective Commissioning for Existing and Low Energy Buildings (*)

Annex 48: Heat Pumping and Reversible Air Conditioning (*)

Annex 49: Low Exergy Systems for High Performance Buildings and Communities (*)

Annex 50: Prefabricated Systems for Low Energy Renovation of Residential Buildings (*)

Annex 51: Energy Efficient Communities (*)

Annex 52: ☼ Towards Net Zero Energy Solar Buildings (*)

Annex 53: Total Energy Use in Buildings: Analysis and Evaluation Methods (*)

Annex 54: Integration of Micro-Generation and Related Energy Technologies in Buildings (*)

Annex 55: Reliability of Energy Efficient Building Retrofitting - Probability Assessment of Performance and Cost (RAP-RETRO) (*)

Annex 56: Cost Effective Energy and CO₂ Emissions Optimization in Building Renovation (*)

Annex 57: Evaluation of Embodied Energy and CO₂ Equivalent Emissions for Building Construction (*)

Annex 58: Reliable Building Energy Performance Characterisation Based on Full Scale Dynamic Measurements (*)

Annex 59: High Temperature Cooling and Low Temperature Heating in Buildings (*)

Annex 60: New Generation Computational Tools for Building and Community Energy Systems (*)

Annex 61: Business and Technical Concepts for Deep Energy Retrofit of Public Buildings (*)

Annex 62: Ventilative Cooling (*)

Annex 63: Implementation of Energy Strategies in Communities (*)

Annex 64: LowEx Communities - Optimised Performance of Energy Supply Systems with Exergy Principles (*)

Annex 65: Long-Term Performance of Super-Insulating Materials in Building Components and Systems (*)

Annex 66: Definition and Simulation of Occupant Behavior in Buildings (*)

Annex 67: Energy Flexible Buildings (*)

Annex 68: Indoor Air Quality Design and Control in Low Energy Residential Buildings (*)

Annex 69: Strategy and Practice of Adaptive Thermal Comfort in Low Energy Buildings (*)

Annex 70: Energy Epidemiology: Analysis of Real Building Energy Use at Scale (*)

Annex 71: Building Energy Performance Assessment Based on In-situ Measurements (*)

Annex 72: Assessing Life Cycle Related Environmental Impacts Caused by Buildings (*)

Annex 73: Towards Net Zero Energy Resilient Public Communities (*)

Annex 74: Competition and Living Lab Platform (*)

Annex 75: Cost-effective Building Renovation at District Level Combining Energy Efficiency and Renewables (*)

Annex 76: ☼ Deep Renovation of Historic Buildings Towards Lowest Possible Energy Demand and CO₂ Emissions (*)

Annex 77: ☼ Integrated Solutions for Daylight and Electric Lighting (*)

Annex 78: Supplementing Ventilation with Gas-phase Air Cleaning, Implementation and Energy Implications

Annex 79: Occupant-Centric Building Design and Operation

Annex 80: Resilient Cooling (*)

Annex 81: Data-Driven Smart Buildings

Annex 82: Energy Flexible Buildings Towards Resilient Low Carbon Energy Systems

Annex 83: Positive Energy Districts

Annex 84: Demand Management of Buildings in Thermal Networks

Annex 85: Indirect Evaporative Cooling

Annex 86: Energy Efficient Indoor Air Quality Management in Residential Buildings

Annex 87: Energy and Indoor Environmental Quality Performance of Personalised Environmental Control Systems

Annex 88: Evaluation and Demonstration of Actual Energy Efficiency of Heat Pump Systems in Buildings

Annex 89: Ways to Implement Net-zero Whole Life Carbon Buildings

Annex 90: ☼ EBC Annex 90 / SHC Task 70 Low Carbon, High Comfort Integrated Lighting

Annex 91: Open BIM for Energy Efficient Buildings

Annex 92: Smart Materials for Energy-efficient Heating, Cooling and IAQ Control in Residential Buildings

Annex 93: Energy Resilience of the Buildings in Remote Cold Regions

Annex 94: Validation and Verification of In-situ Building Energy Performance Measurement Techniques

Annex 95: Human-centric Building Design and Operation for a Changing Climate

Annex 96: Grid Integrated Control of Buildings

Working Group - Energy Efficiency in Educational Buildings (*)

Working Group - Indicators of Energy Efficiency in Cold Climate Buildings (*)

Working Group - Annex 36 Extension: The Energy Concept Adviser (*)

Working Group - HVAC Energy Calculation Methodologies for Non-residential Buildings (*)

Working Group - Cities and Communities (*)

Working Group - Building Energy Codes

Preface

This report has two objectives. One is to share the recognition of the state-of-the-art of current practices for heat pump systems among participating experts in the IEA EBC Annex 88 project 'Evaluation and Demonstration of Actual Energy Efficiency of Heat Pump Systems in Buildings', of which main activity will continue until June 2027. Another objective is to share the state-of-the-art with international, national, and industrial policymakers regarding the decarbonisation of buildings.

As many know, the heat pump is one of the most promising technologies for reducing energy use for space heating/cooling and domestic hot water and efficiently utilising renewable energies. However, inappropriate design and the installation of heat pumps (e.g., capacity determined without sizing procedure, inappropriate operating temperatures, etc.) might negatively affect the energy consumption of this technology and the system payback period might become longer than its lifetime.

Transparent technological information on the heat pump should be exchanged between HVAC designers/building owners and heat pump manufacturers. However, different viewpoints and technical approaches have resulted in inconsistencies that represent an unresolved gap in product and building performance analyses that has limited the potential of the heat pump technology as an integrated part of efficient buildings. It can be said the problem may not be purely technological but a sort of blind spot in existing standards and regulations. Heat pump performance depends highly on the several parameters that define operating conditions. It is difficult to identify and foresee their influences with simple tests and calculation methods. For example, energy efficiency of heat pumps under low partial load conditions (i.e., heat pumps operated inevitably much below their maximum capacity) is not appropriately represented by existing testing standards and calculation methods for building energy codes.

The IEA EBC¹ Annex 88 is a five-year R&D project between July 2022 and June 2027, and comprises the following five subtasks:

- State-of-the-art for testing methods, monitoring methods and database, energy calculation methods and design guidelines
- Testing methods for heat pump products
- Monitoring methods and database
- Calculation methods of energy use by heat pump systems
- Design guidelines for HVAC system designers

¹ IEA EBC is the abbreviation of the International Energy Agency, Energy in Buildings and Communities Program. See <https://iea-ebc.org/>.

Executive Summary

1. Findings in the State-of-the-art

Chapter 1: testing methodologies and performance rating standards for heat pump systems

- In currently used testing methodologies (referred to in this report as Category A standards), heat pumps are tested in steady state conditions that are obtained by deactivating the built-in control of the tested unit and fixing the compressor speed with proprietary test modes at defined load conditions. The impacts of decreased performance during part-load operation (equipment on/off cycling) as well as defrost cycles are not directly accounted for in such test procedures. This can lead to seasonal performance values that do not fully account for the drop in performance experienced during these non-steady-state operating modes.
- It has been increasingly recognised that energy performance at lower partial load conditions cannot be neglected when estimating the actual energy performance of heat pumps in buildings and test conditions should cover such operating modes (particularly because the actual part-load ratio can be much smaller in practice than that expected by the developers of such testing standards). In fact, HVAC designers who are engaged in sizing heat pumps may often use a “safety margin” and over-size equipment to avoid a risk of complaints from their customers due to the perceived risk of shortage of capacity.
- In response to the need to compensate for the above shortfall of current testing standards, there are ongoing projects to develop load-based testing standards (referred to in Category B standards). In the load-based testing standards, the actual operation of variable-speed heat pumps and air conditioning units are tested with the same control as operated in buildings (i.e., “native controls”). Four projects that have developed such load-based test standards are reviewed in this report: three for air-to-air heat pumps (Waseda University, Canadian Standard Association and BRI/Better Living) and one for air-to-water heat pumps (BAM/RWTH).
- These newly developed load-based test methodologies and standards aim to replace current fixed-speed test standards. They may also help to inform building-level simulation and policy objectives by providing more representative data for energy calculation methodologies, equipment sizing, and design guidelines, internationally or nationally. Indeed, the extent to which these newly developed load-based test methodologies may support the needs of building-level simulation is a subject of the next phase of work in this Annex.
- The repeatability, reproducibility, and representativeness (3Rs) of the results of these newly developed load-based test methodologies and standards must be assured through ongoing R&D projects (this work is underway and will be evaluated during the next phase of work in this Annex).
- A project to develop the new ISO 21280 standard by adopting a load-based testing methodology for air-to-air products has already been launched within ISO/TC86/SC6/WG15, with the engagement of Annex 88 experts. Similarly, for hydronic heat pumps, CEN/TC113/WG8 has worked on a load-based test with Annex 88 experts involved.

Chapter 2: monitoring methods and database for actual energy efficiency of heat pump systems

- By overcoming obstacles to installing sensors in occupied buildings, the most realistic phenomena for heat pump systems can be monitored. Plenty of informative monitoring results already confirm the non-steady state condition of heat pumps, how low the partial load ratio is, the discrepancy between efficiency values based on current testing standards and actual energy efficiency, etc.
- Methods for monitoring are grouped into those for air conditioners (e.g., VRF, room air conditioner) and hydronic heat pump systems transporting heat by water. For air conditioners, 1) indoor side air enthalpy difference methods, 2) outdoor side air enthalpy methods, and 3) refrigerant specific enthalpy

difference methods exist. For hydronic heat pump systems, the water side method is available when the water side is accessible besides 2) and 3) as for air conditioners.

- Standards for the monitoring method exist, such as T/CAS 305-208 and ASHRAE Standard 221-2020. An ISO project is also developing a new standard to prescribe a monitoring method.
- Eight monitoring projects are reviewed in this report.

Chapter 3: energy use calculation methods for heat pump systems

- Building energy policies emerged in the 1970s, triggered by the 1973 oil crisis, and evolved in the 1980s. In the 1990s, they integrated the energy efficiency of building technical systems (e.g., heating systems, lighting, etc.), and they continued evolving in each nation, reflecting local traditions of relevant industries. A variety of methods flourished, especially for technical systems and their calculation of energy consumption. This variety of methods is even more evident for new technologies like heat pumps, and there is an urgent and obvious need for reliable heat pump energy calculation methods.
- Current challenges for energy calculation methods are 1) reasonable accuracy, 2) comprehensiveness (i.e., coverage of all major types), 3) availability of input data based on product testing standards, 4) easily understood by practitioners, 5) objectivity and unbiasedness, and 6) proof of energy calculation methods.
- Specific challenges for calculating heat pump energy consumption include the sensitive dependency of energy efficiency on operating conditions (e.g., part load ratio, outdoor temperature, supply hot water temperature), and control options. Adequate information (i.e. test data) is required to be the input to reliable energy calculation methods.
- Existing energy calculation methods for heat pumps are reviewed in Chapter 3. They are 1) European standards based on EN 15316-4-2 and EN 16798-13, 2) EnergyPlus, 3) NECB (National Energy Code of Canada for buildings), 4) Building Energy Conservation Standard of Japan, 5) UNI-TS 11300-4 of Italy, 6) DIN V 18955 of Germany, 7) SBEM (for non-residential buildings) of UK, and 8) SAP (for residential buildings) of UK.

Chapter 4: design guidelines for heat pump systems in buildings

- Existing installation and design guidelines for heat pump systems that are reviewed in Chapter 4 included:
 1. European standard EN 15450 is being revised. It is a design standard for hydronic (water based) heating systems with heat pumps for residential buildings. The ongoing revision will introduce a comprehensive approach to all design issues of a heat pump system, focusing specially on renovation, also extended to cooling and non-residential buildings. Reference is made to EN 15316-4-2, revised in parallel, to determine the resulting seasonal efficiency and evaluate the design choices. Several influence factors are considered, and various design techniques and computations are proposed to limit the cyclic operation during part load conditions and achieve appropriate operating conditions. Several sizing techniques are suggested to prevent oversizing, making use of historical energy consumption data when available. Guidance is included on the sizing of the volume of hot water storage, on the design of hydraulic circuits, and the way to estimate costs. A German standard as guidelines for heating systems with heat pumps in single and multi-family houses and Danish guidelines are also reviewed as examples of European guidelines for heat pumps.
 2. The ASHP (Air Source Heat Pump) Sizing and Selection Toolkit has been developed by NRCan (Natural Resources Canada). The Toolkit It is intended for use by mechanical system designers and renovation contractors and provides a step-by-step sizing and selection procedure and an Excel-based and online tool. CSA (Canadian Standards Association) published an 'HVAC guide for Part 9 homes' as CSA SPE-17:23, in which technical information on various HVAC systems, not only for heat pumps systems, is provided for housing and small buildings defined in Part 9 of National Building Code of Canada. In the US, ACCA (the Air Conditioning Contractors of America), which is an HVAC industry association, has published several relevant design manuals, ANSI/ACCA 3 Manual S (2014) - Residential Equipment Selection and ANSI/ACCA 1 Manual D

(2016) – Residential Duct Systems. NEEP (the Northeast Energy Efficiency Partnership) has produced two guides for sizing, selecting and installing ASHP for residential buildings in cold climates with support from the US DOE, including an online sizing tool.

3. ISO 13153:2013 Framework of the design process for energy-saving single-family residential and small commercial buildings prescribes how to integrate quantitative information on energy use reduction by applying technologies, including heat pumps, and their specifications, such as the rated energy efficiency of heat sources. According to the ISO, the Building Research Institute has published design guidelines.
- The design guidelines to be developed by Annex 88 should be focused on 1) the sizing procedure of heat pumps, 2) countermeasures to avoid operation under low partial load conditions and to improve energy efficiency under the low partial load condition by selecting products (referring to the load-based test methods and provided performance indices), 3) emphasising the critical role of controlling the systems together with a transparent specification of the control logics, 4) quantitative information on the energy use by different specifications and product selections in coordination with energy use calculation methods to be tackled in Subtask C (Subtask for energy calculation). Examples of monitoring results in fields shall be introduced based on the deliverable from Subtask B2 (Subtask for monitoring). Limiting the scope to a few major types of heat pump systems (e.g., air-to-air system and air-to-water hydronic system) is also necessary.

2. Message to policy makers related to heat pump products' evaluation and to building energy codes and performance certification schemes

- Policymakers already know the importance and potential of promoting the heat pump market. It is absolutely a correct judgment. However, one-sided promotion is not enough, and it is indispensable to support the provision of transparent technical information to practitioners by reorganising and strengthening industrial standards and guidelines so that the potential of heat pumps is fully achieved.
- Good players (e.g., the manufacturing industry of heat pumps) already exist. Still, without good referees and rules, they are not good enough to fully use the potential of heat pumps to save much energy use. There is a recognition that industries take care of themselves for product standardisation and producing practical guidelines for their business, even though it seems almost impossible to depend on different players to make rules, or it will take much time to see the ideal situation.
- The connection between product data and energy performance calculations is not yet well established, making it difficult to produce reliable and easy-to-use energy performance calculations.
- Policy makers are requested to refer to the situation of existing testing standards for heat pumps (Chapter 1), information on their actual energy efficiency (Chapter 2), how relevant engineers engaged in international and national energy use calculation are struggling (Chapter 3), and the present situation of guidelines for practitioners (Chapter 4).

3. Prioritised R&D targets for the working phase of IEA EBC Annex 88

- Validation of proposals for the load-based test methods for heat pump systems.
- Exploration of ways in which load-based test methods could be leveraged to inform building energy simulation needs and inform building-level policy (e.g., generating performance map data using load-based testing).
- Preparation of standard proposals for monitoring methods and collecting monitoring results to be published in a deliverable.
- Development of more reliable energy calculation methods for heat pump systems with examples.
- Development of a design guideline for heat pump systems with quantitative information on energy saving by different designs and specifications.

Table of content

- Preface 10
- Executive Summary..... 11
- Acronyms and Abbreviations..... 17
- Explanations of technical terms..... 18
- 1. State of the art of testing methodologies and performance rating standards for evaluating the actual energy efficiency of heat pumps and air conditioners 23
 - 1.1 Categories of testing standards and their backgrounds..... 23
 - 1.2 Current testing methodologies and performance rating standards for heat pump systems (Category A Standards)..... 25
 - 1.2.1 Targeted heat pump systems and scope 25
 - 1.2.2 Test methods..... 26
 - 1.2.3 Control of test specimens during tests 26
 - 1.2.4 Performance indices and requirements for part load tests 26
 - 1.2.5 Tolerance of measurement uncertainty..... 27
 - 1.2.6 Other issues 27
 - 1.3 New type testing standards for heat pump systems (Category B Standards) 27
 - 1.3.1 Overview of load-based testing methodologies 27
 - 1.3.2 Emulator-type load-based testing methodology for air conditioners by Waseda University .. 32
 - 1.3.3 CSA SPE-07:23 Load-based and climate-specific testing and rating procedures for heat pumps and air conditioners 36
 - 1.3.4 Load-based test to obtain relationships between partial load ratio and energy efficiency of VRF systems by Better Living 40
 - 1.3.5 Load-based testing of hydronic heat pumps - load-based method (by BAM) and hardware-in-the-loop testing (by RWTH) 46
 - 1.4 Perspectives of load-based test standards and R&D plans in Annex 88..... 51
 - 1.4.1 Perspective of load-based tests and considerations on methods of utilization of the results 51
 - 1.4.2 Perspective within Subtask B1 of Annex 88 Perspective of load-based tests and considerations on methods of utilization of the results..... 54
 - 1.5 References for testing methods 55
- 2. State of the art for field monitoring methods and database for actual energy efficiency of heat pump systems 58
 - 2.1 Background 58
 - 2.2 Current field monitoring methods 59
 - 2.2.1 Air-air heat pump systems..... 59
 - 2.2.2 Air-water (hydronic) heat pumps 64
 - 2.3 Existing standards and protocols for monitoring methods for heat pump systems 65

2.3.1	China's specifications and standards	65
2.3.2	Canada's specifications	67
2.3.3	US's specifications	68
2.3.4	Europe's specifications	69
2.4	Existing data on monitored energy efficiency of heat pump systems and comparison with laboratory test results	70
2.4.1	Case 1 (VRF).....	70
2.4.2	Case 2 (VRF).....	72
2.4.3	Case 3 (RAC)	74
2.4.4	Case 4 (Water-water HP)	76
2.4.5	Case 5 (Water-water HP)	79
2.4.6	Case 6 monitoring projects for air-to-water heat pumps by Fraunhofer ISE	80
2.4.7	Case 7 monitoring projects for air-to-water heat pumps by Eastern Swiss University of Applied Sciences	81
2.4.8	Case 8 IEA Heat Pumping Technologies TCP projects and SEPOMO-Build	81
2.5	Perspectives of monitoring of actual energy efficiency of heat pump systems and R&D plans in Annex 88	82
2.6	References for monitoring methods and database	83
3.	State of the art for energy use calculation methods for heat pump systems	86
3.1	Introduction (context of energy performance calculation methods and standards)	86
3.1.1	Context/Background	86
3.1.2	Challenges	88
3.2	Heat pump energy performance basics	91
3.2.1	Definition of energy performance indicators and common parameters	91
3.2.2	Influence factors	94
3.2.3	Connection with the overall building energy performance calculation	99
3.3	Current methods.....	99
3.3.1	EN standards.....	99
3.3.2	EnergyPlus	114
3.3.3	National energy code of Canada for buildings	118
3.3.4	Japanese standard, BECS	120
3.3.5	Italy UNI-TS 11300-4.....	127
3.3.6	UK SAP 10.2	130
3.3.7	Germany DIN V 18599	132
3.3.8	France RE 2020	134
3.3.9	UK SBEM for non-residential buildings	137
3.4	Discussion	139
3.5	Perspectives of the future development of energy calculation methods for heat pump systems and harmonization with their testing methods.....	143
3.6	References	144
4.	State of the art on design guidelines for heat pump systems in buildings	147
4.1	Background	147
4.2	Existing guidelines for designers and installers of heat pump systems in buildings.....	148
4.2.1	European guidelines.....	148

4.2.2	Canadian codes and practices	160
4.2.3	US.....	166
4.2.4	ISO 13153:2012 and Japanese design guidelines for low energy housing with validated effectiveness.....	171
4.3	Perspectives of developing design guidelines for heat pump systems in Annex 88	177
4.4	References	181

Acronyms

Acronyms	Meaning
AA, A/A	Air to air
AE	Air specific enthalpy
APF	Annual performance factor
ASHP	Air source heat pump
AW, A/W	Air to water
BES	Building Energy Systems
CEC	Compressor energy conservation
COP	Coefficient of performance
CSEC	Compressor set energy conservation
CT	Cooling tower
CVE	Compressor volumetric efficiency
DBT	Dry-bulb temperature
EER	Energy efficiency ratio
EPBD	Energy Performance of buildings directive
GSHP	Ground source heat pump
HiL	Hardware-in-the-Loop
HP	Heat pump
HX	Heat exchanger
IC	Indoor conditions
KPI	Key performance indicator
MPC	Model predictive controller
MQTT	Message Queuing Telemetry Transport
nZEB	Nearly zero-energy building
OC	Outdoor conditions
PLR	Partial load ratio
PV	Photovoltaic
RAC	Room air conditioner
RE	Refrigerant specific enthalpy
RH	Relative humidity
RRT	Round robin tests
SCOP	Seasonal coefficient of performance
SEER	Seasonal energy efficiency ratio
TC	Technical Committee (e.g., ISO TC163, CEN TC371)
TES	Thermal energy storages
VRF	Variable refrigerant flow
VRV	Variable refrigerant volume
WA, W/A	Water to air
WBT	Wet-bulb temperature
WW, W/W	Water to water
3Rs	Repeatability, reproducibility, and representativeness

Abbreviations

Abbreviations	Meaning
AHRI	Air-Conditioning, Heating, and Refrigeration Institute
ANSI	American National Standards Institute
ASHRAE	American Society of Heating, Refrigerating and Air conditioning Engineers
CEN	Comité Européen de Normalisation
CSA	Canadian Standards Association
EN	Europäische Norm (European Norm)
ISO	International Organization for Standardization
JIS	Japanese Industrial Standards
NEEP	Northeast Energy Efficiency Partnership
NT VVS	Nordtest Värme, Ventilation, och Sanitet (Heating, Ventilation, and Sanitation)
T/CAS	China Association for Standardization
T/CECS	China Association for Engineering Construction Standardization
UNI	Ente Italiano di Normazione (Italian Standardization Body)
VDI	Verein Deutscher Ingenieure (Association of German Engineers)

Explanations of technical terms

The following explanations of key technical terms, which appear in this report, are intended to provide reference information for broader experts, practitioners and policy makers to understand the state-of-the-art (problems and possible solutions) for heat pump systems in buildings. More detailed and accurate definitions should be found in relevant standards for terminology, and the definitions of new technical terms and concepts shall be determined in the working/reporting phase of Annex 88 during 2024 and 2027.

Adiabatic compression: an ideal thermodynamic process where the pressure of a gas/vapour increases without any heat transfer to or from the system.

Air specific enthalpy (AE) method: methods to obtain cooling or heating capacity of heat pumps by measuring air volume and air enthalpy difference of the air flowing through indoor unit or outdoor unit.

Air-to-air (air-air) heat pumps: heat pumps with outdoor air as heat source and indoor air as heat sink.

Air-to-water (air-water) heat pumps: heat pumps with outdoor air as heat source and water as heat sink.

Annual average efficiency: average energy efficiency throughout whole year.

Auxiliaries: components attached to the main part of heat pump systems.

Back-up generator (heater): electric heater or boiler, which compensates for the shortage of the capacity of heat pumps, especially when outdoor temperature is very low.

BIN method: a simplified calculation method of heating need, cooling need and energy use for heating and cooling by using numbers of hours in each range of outdoor temperature for each month for a location.

Bivalent operation: simultaneous operation of heat pump and back-up heater to compensate for the shortage of the heat pump capacity at outdoor temperature lower than a set-point outdoor temperature.

Bivalent temperature: a temperature, below which a back-up heater is needed.

Buffer storage: hot or cold water storage to be prepared for thermal need larger than heat or cold production by heat generators (heat pumps).

Built-in control: control built-in to the heat pump equipment at the time of factory shipment.

Capacity: amount of output by heat pump systems.

Category A standards: current test standards for heat pumps, which apply proprietary control in order to maintain the steady state of the heat pumps and their continuous operation.

Category B standards: load-base test standards, which apply built-in (native) control of heat pumps. During the test, according to Category B standards, heat pumps may operate intermittently.

Carnot efficiency: theoretical maximum efficiency that a heat engine can achieve when operating between two temperatures: a hot reservoir (source) and a cold reservoir (sink). It is defined as the ratio of the work output of the engine to the heat input from the hot reservoir. The Carnot efficiency depends solely on the temperatures of these two reservoirs.

Compressor: device for increasing the pressure of a gas/vapour by mechanically decreasing its volume.

Continuous operation: operation of heat pumps at constant input and output.

Cooling need (cooling load, energy need for cooling): heat to be extracted from a thermally conditioned space to maintain the intended space temperature and humidity conditions during a period.

Defrost operation: operation of heat pumps to remove frost on coils of outdoor units. During the defrost operation, compressed refrigerant is supplied to the coils of the outdoor units to be heated.

Degradation coefficient (C_D): reduction rate of energy efficiency to apply to estimate energy efficiency under intermittent operation of heat pumps.

Emulator: a control method of temperature of return air (or water) to indoor unit (or to heat pump) in order to consider the influence of the thermal inertia of the buildings and the heat transport systems on the temperature.

EN (CEN) Standards: European standards developed by Technical Committees of the European Committee for Standardisation.

EN-EPB standards: a set of EN standards and accompanying technical reports to support EPBD.

Energy calculation method: a method to calculate energy use (consumption) of a building or a component of the building such as its HVAC system, its domestic hot water system. National building energy codes and standards have their own energy calculation methods to quantify the energy performance of buildings.

Energy Efficiency Ratio (EER): energy efficiency of heat pumps when they operate for space cooling. However, in some countries and regions, EER is not used, and COP is used for both space heating and cooling.

Energy use (energy consumption): energy input to systems (e.g., heating, cooling and domestic hot water systems).

EPBD (Energy Performance of Buildings Directive): An EU directive is a legal act adopted by the EU institutions addressed to the EU Member States. It sets out an objective to be achieved but leaves it to individual countries to implement it in their own way. EPBD is the EU directive aims to achieve a fully decarbonized building stock by 2050.

Equipment sizing: an important process of the design of building services, in which the capacity of equipment is decided.

Expansion Valve: valve reducing the pressure of the liquid refrigerant to allow expansion or change of state from a liquid to a vapor in the evaporator.

Fixed-compressor speed test: performance test of heat pumps by fixing the rotation speed of the compressor to maintain stable condition.

Hardware-in-the-loop testing: test method for heat sources (e.g., heat pumps) connected with the hardware comprising secondary water circuit and thermal load simulator where the loads are based on simulations.

Heat need: amount of heat to be provided or extracted by space heating system or space cooling system, respectively, to maintain indoor thermal condition. It can be the amount of heat to be provided to supply hot water at a certain temperature and amount.

Heat pump: a device to move heat from air or liquid of lower temperature to that of higher temperature. It is used for space heating and cooling as well as for domestic hot water in buildings as a promising energy saving measure.

Heat sink, sink: substance, to which heat is dissipated by heat pump systems (e.g., indoor air or hot water for heating operation of heat pumps)

Heat source, source: substance, from which heat is extracted by heat pump systems (e.g., outdoor air or groundwater for heating operation of heat pumps).

Heating need (heating load, energy need for heating): heat to be delivered to a thermally conditioned space to maintain the intended space temperature conditions during a period.

Hydronic heat pumps: heat pumps with water circuits to provide space heating or cooling as well as domestic hot water.

Input (energy input): energy supplied to equipment such as electricity supplied to a heat pump.

Intermittent operation: operation of heat pumps cyclically raising and reducing their input and output.

Inverter (inverter technology): a power electronic device or circuitry to convert DC to AC electricity.

ISO Standards: International Standards developed by Technical Committees of the International Organization for Standardization.

Legionella disease: a form of atypical pneumonia (severe lung inflammation) caused by any species of Legionella bacteria. The bacteria can contaminate hot water in tanks and pipes.

Load-based test: test method imposing thermal load on heat sources (e.g., heat pumps) without using proprietary control for the heat sources.

Multi-split system: air conditioning system with at least one outdoor unit and multiple indoor units.

Native control: the same as built-in control.

nZEB (Nearly Zero Energy Building): buildings with a high energy performance and very low-energy needs, covered largely by onsite and nearby renewable energy sources.

On-board control: the same as built-in control.

On-off cycling: operation of heat pumps cyclically changing their status (switched on and off) to adjust output to heating or cooling need.

Output (energy output): energy generated by equipment such as thermal energy generated by a heat pump.

Part load: heating or cooling load, which is less than the maximum heating or cooling capacity of the heat pump systems dealing with the load.

Part load condition: condition in which heat pumps are operated at capacity lower than maximum.

Part load ratio, Partial load ratio: the ratio of the actual capacity of a heat source to its rated capacity.

Part load factor (LR): the ratio of the actual required power output in the calculation interval to the maximum power output in the given operating conditions for source and sink temperature.

Performance curves: curves (functions) representing the influence of heat source and sink temperatures on full capacity of heat pumps and the influence of part load operation on COP and EER.

Performance map: data set representing the influence of heat source and sink temperatures on the capacity of heat pumps and the influence of part load operation on COP and EER.

Performance mapping (performance map): multiple dimensional table(s) containing performance data of heat pumps. The values represent performance of heat pumps at different operating conditions such as for source temperature, sink temperature and part load ratio.

Performance monitoring: collection of data for status of targeted equipment or system.

Performance rating method (performance rating methodology): a method to calculate a single or only a few indices, which represent energy performance of heat pumps, based on parameters obtained through test methods.

Primary circuit: a hot or cold water circuit between heat generators (heat pumps) and tanks or headers.

Product data: data describing performance of a product. For heat pump products, rated capacity, COP, EER, SCOP, SEER, HSPF, APF, etc.

Proprietary control (proprietary mode): control, which is implemented only for test and of which algorithm is different from that of the built-in control.

Psychometric chamber: chamber, of which dry-bulb temperature and humidity can be controlled by its own air conditioning system.

Reconditioning equipment: equipment for conditioning air from the unit under test at set point dry-bulb temperature and humidity.

Refrigerant specific enthalpy (RE) method: methods to obtain cooling or heating capacity of heat pumps by quantifying the refrigerant mass flow rate and by calculating the enthalpy difference between the refrigerant at inlet and outlet of the indoor heat exchanger.

Room air conditioner (RAC): relatively small capacity air conditioner, which comprises a refrigerator and fans.

Seasonal average efficiency: energy efficiency of heat pumps is affected by outdoor climate conditions, such as dry-bulb temperature, and the specific heating demand they handle at any given time. Seasonal average efficiency of heat pumps is average of energy efficiency during heating season or cooling season, which is calculated taking outdoor climatic conditions and heat need throughout each season.

Seasonal Coefficient of Performance (SCOP): average of energy efficiency of heat pumps for heating season.

Seasonal Energy Efficiency Ratio (SEER): average of energy efficiency of heat pumps for cooling season.

Sink temperature: temperature of a sink, to which a heat pump transfers heat extracted from a source. The sink is at a higher temperature than the source.

Source temperature: temperature of a source, from which a heat pump extracts heat and transfer it to a sink. The source is at a lower temperature than the sink.

Testing method (testing methodology): a method to measure the capacity and the energy consumption of heat pumps at conditions for temperatures of heat source and heat sink.

Tolerance: allowable errors of mean values or individual readings from specified test conditions.

Uncertainty (of measurement): an estimate characterising the range of the values within which the true value of the measurement lies based on a specific confidence interval.

Variable Refrigerant Flow (VRF) system, Variable Refrigerant Volume (VRV) system: heat pump system using refrigerant, of which flow rate is variable according to thermal load, to transport heat or cold between outdoor unit and indoor unit.

Variable speed system: system which can change rotational speed of the electric motor driving the compressor.

1. State of the art of testing methodologies and performance rating standards for evaluating the actual energy efficiency of heat pumps and air conditioners

Statement of purpose

The following objectives summarise the main purpose of the present subtask (The term “heat pump” includes both air-to-air and hydronic heat pumps.):

- to review presently adopted testing methodologies and performance rating standards for air conditioners and heat pumps,
- to review newly proposed testing methodologies and performance rating standards for air conditioners and heat pumps,
- to define the requirements and tolerance for the testing equipment, instrumentation, and auxiliaries, the system operation and setpoints during the test, as well as performance indices for evaluating the actual system efficiency,
- to consider possible improvements of existing and new testing methodologies for assessing the performance of heat pumps and air conditioners when operated under the same control as operated in buildings,
- to consider methods of utilisation of the test results for performance rating, performance mapping, and energy calculation methods (Subtask C), provide evidence for efficient equipment sizing (Subtasks C and D), system design and control (Subtask D), as well as support for the development of performance monitoring techniques (Subtask B2).

1.1 Categories of testing standards and their backgrounds

Using the inverter technology for variable speed systems has enhanced the system’s adaptability in managing thermal loads with potentially high efficiency in a broad range of operating conditions. During field operation heat pumps and air conditioners respond to specific building loads and indoor temperature variations with dynamic modulations of the compressor speed and expansion valve opening defined by their built-in (or “on-board”) control system, which is referred to as “native control” and is opposed to proprietary modes used only during current rating tests. The control mode adopted during tests is at the essence of the definition of the following two categories of testing methodologies and rating standards. In fact, current testing procedures are experimental tests at fixed compressor speed conducted while deactivating the native control system of the unit.

Therefore, rating procedures based on such a simplified testing method yield results that may deviate significantly from the actual operating performance. This underlying gap between the actual and rated performances has been recognised as a major challenge for effectively driving energy conservation of heat pump installations, besides improving system design and quality of installation.

In the attempt to guide the development of new standards that can cover such performance gap and represent the system field efficiency more realistically, this subtask reviews two categories of testing methodologies and corresponding performance rating standards:

- (Category A) Current testing methodologies and performance rating standards conducted at fixed compressor speed (fixed capacity ratio) while deactivating the native control system.
- (Category B) Newly proposed testing methodologies for evaluating the performance of heat pumps

and air conditioners under the same control as operated in buildings (active native control).

Table 1.1-1 compares Category A standards and Category B standards for heat pumps. The operation mode of the unit defined by the testing methods differentiates the two categories.

Performance rating standards are intended as product-level policies, which provide values representing products' energy efficiency and are referred by users to compare different products of the same kind. However, it should be noted that new testing methods for evaluating heat pumps operated under their native control can also apply to building-level evaluation, extract performance maps, and to support energy calculations.

Table 1.1-1. Comparison of Category A standards and Category B standards.

	Category A standards: Development in HP industry	Category B standards: Being developed by independent research entities
(1) Operation mode during tests for energy efficiency	<p>Native control is overridden by proprietary control as required for testing. Generally, the tested unit <u>is forced in steady state condition by fixing the compressor speed (with proprietary controls)</u>.</p> <p>Generally, provides reliable hardware testing, but excludes evaluation of performance in all modes of operation across the operating temperature range.</p> <p>This way of testing is often considered indispensable to maintain a high accuracy and reproducibility, but this comes at the expense of comprehensive performance evaluation of the unit under test.</p> <p>Note that native control testing, cycling mode and defrost mode operation may be tested at discrete conditions, but are not tested across the full operating range of the equipment.</p>	<p><u>HP is operated under the same control as operated in the building (native controls)</u>.</p> <p>Tests are conducted with generally equivalent equipment and instrumentation as in Category A standards. Repeatability, reproducibility and representativeness studies are ongoing. However, evidence of the level of repeatability and reproducibility similar to Category A standards have been presented in recent literature. Recent studies of Representativeness suggest an improvement over Category A standards (i.e., that seasonal performance results using Category B standards are more representative of in-field test results than those produced by Category A standards)</p> <p>Note that Category B standards testing may require specialized test apparatus and/or capabilities (while instrumentation remains generally equivalent).</p>
(2) Seasonal or annual average efficiencies	<p>Necessary for regulating the energy efficiency level of each product category.</p> <p>The choice of test conditions required to extract these seasonal performance indexes is based on:</p> <p><u>-Assumption of the relationship between heat needs imposed on HP and the maximum capacity of the HP:</u> fixed ratios are applied, such as 1.0 for cooling in JIS C 9612.</p> <p><u>-Assumption on the relationship between the heat needs and outdoor temperature:</u> a linear relationship is assumed.</p> <p>*(for Category B standards) Assumption of reference building thermal and moisture characteristics are required and affect the time dependent system response captured.</p>	

1.2 Current testing methodologies and performance rating standards for heat pump systems (Category A Standards)

Current performance rating standards are reviewed for the following aspects:

- 1) Targeted heat pump systems and the scope,
- 2) Test methods,
- 3) Temperature conditions,
- 4) Control of test specimens during tests,
- 5) Performance indices and requirements for part load tests,
- 6) Tolerance of measurement uncertainty,
- 7) Other issues.

The current standards reviewed are listed in Table 1.2-1.

Table 1.2-1. List of the current testing and rating standards reviewed

No.	Title of standard	Year
1	ISO 5151. Non-ducted air conditioners and heat pumps – Testing and rating for performance	2017
2	ISO 13253. Ducted air-conditioners and air-to-air heat pumps – Testing and rating for performance	2017
3	ISO 15042. Multiple split-system air-conditioners and air-to-air heat pumps – Testing and rating for performance	2017
4	ISO 16358. Air-cooled air conditioners and air-to-air heat pumps – Testing and calculating methods for seasonal performance factors – Part 1: Cooling seasonal performance factor, Part 2: Heating seasonal performance factor, Part 3: Annual performance factor	2013
5	EN 14511-1, 2, 3. Air conditioners, liquid chilling packages and heat pumps for space heating and cooling and process chillers, with electrically driven compressors	2022
6	EN 14825. Air conditioners, liquid chilling packages and heat pumps, with electrically driven compressors, for space heating and cooling - Testing and rating at part load conditions and calculation of seasonal performance	2022
7	AHRI 210/240. Performance Rating of Unitary Air-conditioning & Air-source Heat Pump Equipment	2020
8	AHRI 340/360. Performance Rating of Commercial and Industrial Unitary Air-conditioning and Heat Pump Equipment	2022
9	AHRI 310/380. CSA-C744-17. Packaged Terminal Air-conditioners and Heat Pumps	2017
10	AHRI 550/590. Performance Rating of Water-chilling and Heat Pump Water-heating Packages Using the Vapor Compression Cycle	2023
11	AHRI 1230. Performance Rating of Variable Refrigerant Flow (VRF) Multi-Split Air-conditioning and Heat Pump Equipment	2023
12	ANSI/ASHRAE Standard 37-2009 (RA 2019). Methods of testing for rating electrically driven unitary air-conditioning and heat-pump equipment	2019
13	ANSI/ASHRAE 206-2013 (R2017). Method of Testing for Rating of Multipurpose Heat Pumps for Residential Space Conditioning and Water Heating	2017
14	JIS B 8616. Package Air Conditioners	2015
15	JIS B 8627. Gas Engine Driven Heat Pump Air Conditioners	2015

1.2.1 Targeted heat pump systems and scope

Targeted heat pump systems can be categorised according to a) heat source (air or water) and secondary medium for heating and cooling supply to emitters, b) configuration of the heat pump systems, e.g.,

'packaged', 'unitary', 'multi-split', 'ducted', 'non-ducted', c) drive of the compressor (e.g., electrically-driven, gas engine driven), and d) capacity (e.g., 19 kW or greater).

1.2.2 Test methods

This aspect is well categorised in ANSI/ASHRAE Standard 37(ANSI/ASHRAE, 2019) and ISO 5151 (ISO, 2017a). According to the former standard, there are five test methods:

- a. indoor air enthalpy method,
- b. outdoor air-enthalpy method,
- c. compressor calibration method,
- d. refrigerant enthalpy method,
- e. outdoor liquid coil method.

For the indoor and outdoor enthalpy methods, only the nozzle airflow measuring apparatus, which needs a tunnel (duct) to allow rectifying the airflow before the nozzle and to compensate the pressure loss due to the nozzle and other parts of the tunnel by using a fan, is specified. The tunnel is also used for measuring dry-bulb and wet-bulb temperatures of well-mixed air from the unit.

Besides the five test methods above mentioned, ISO 5151 prescribes calorimeter test methods. According to ISO 5151, capacity tests shall be conducted using either the calorimeter test method or the indoor air enthalpy test method.

1.2.3 Control of test specimens during tests

Most current standards only deal with stable conditions for test specimens. The necessity of manufacture instructions to achieve the stable condition is clearly prescribed by standards. It is well recognised that the intermittent operation of test specimens reduces their energy efficiency compared with continuous and stable operation, and the difference is represented in plural standards by the degradation coefficient (C_D). For the test to quantify the C_D , the cycle test is prescribed by some standards, besides the test under stable conditions. In most standards specifying seasonal average efficiencies, a default value of the C_D is specified, such as 0.25.

In JIS B 8616 (JIS, 2015a), JIS B 8627 (JIS, 2015b), and AHRI 1230 (AHRI,2010), a control verification procedure has been added to verify that the minimum compressor speed for the part-load test can occur without overriding control settings. However, in current testing standards for heat pump systems, including those three standards, overriding control of the specimen during the tests is officially permitted.

1.2.4 Performance indices and requirements for part load tests

For the energy performance rating, EER (Energy Efficiency Ratio) and COP (Coefficient of Performance) are the common basic indices. The unit of the indices varies, but the meaning of the indices does not change, namely the ratio of the capacity to the input energy.

In various standards, integrated indices are provided, of which roles represent seasonal average energy efficiencies. For that purpose, the measurement of energy efficiencies under part load conditions by the tests or the calculation of the energy efficiencies under the part load conditions by using measured values such as for full load and conversion factors is specified in those standards. Instructions and support by manufacturers are necessary to achieve stable operation in part load conditions. As for the part load conditions, in some standards, tests for 75%, 50%, and 25% of full capacity are required, while estimating energy efficiency under lower part load conditions is done using the C_D .

1.2.5 Tolerance of measurement uncertainty

Because of the accuracy limit of measurement devices, standards specify tolerances. Among parameters, measuring airflow rate and temperature may be the most difficult, partly because of their spatial distribution, even if the specimens are in steady operations. If the measurement is conducted under possibly unsteady operation, such as in load-based tests, measurement uncertainty probably becomes larger, and the requirement for the tolerance of measurement uncertainty should be an important issue for their standardization.

1.2.6 Other issues

To express capacities of the specimen under tests, various terminologies are used. They include 'full capacity', 'rated capacity', 'nominal capacity', 'extended capacity', etc. Sometimes, the full capacity is the same as the rated capacity. In the definition of part-load ratio, the ratio's denominator can be different, and the definition resultantly becomes unclear. When analysing energy performance under the part load condition, defining the part load ratio by using the maximum capacity at a certain temperature condition is best. However, there is still an open question on the issue.

1.3 New type testing standards for heat pump systems (Category B Standards)

1.3.1 Overview of load-based testing methodologies

The actual operation of variable-speed heat pumps and air conditioning units may respond with variable or cyclic modulations of the compressor speed and expansion valve opening even to constant thermal loads according to their native control system. Therefore, the corresponding field efficiency of the system may be significantly affected by the control strategy developed and implemented in operating units. Contrary to steady-state operation, the dynamic operation of the system involves a time-dependent thermal interaction between the building thermal characteristics and the capacity supplied by the unit, whereby cooling/heating capacity and the building load are not necessarily and continuously balanced. The magnitude of the unbalance drives a variation of the room temperature and, for a unbalance, the rate of change is related to the equivalent heat capacity of the room. Similar observations apply to the moisture balance, which defines the response of the room condition to a given latent load scenario. Therefore, when dynamic operation is accounted for, the test conditions and the building structural features affect the room thermal response and, in turn, the air conditioner/heat pump performance (Mehrfeld, 2022).

Conventional lab tests for residential heat pumps and air conditioners (such as AHRI 210/240 (AHRI, 2023), JIS B 8615 (JIS, 2015c), or EN 14511 (BSI, 2018)) use fixed compressor speed and expansion valve opening conditions (and hereinafter will be referred to as "fixed condition" tests). In load-based tests, the tested unit is installed following the manufacturer's instructions as it would be done by a qualified field technician, and during the test the system meets heating and cooling loads that are typical for residential applications, using its own thermostat and internal control logic to respond to changes in the room temperature, in case of air-to-air units, or the water inlet temperature in the case of hydronic heat pumps. In this way, the lab environment during the test process emulates a real-life installation, while allowing for consistent control and measurement so that each test can be consistent in its results and provide fair performance comparisons between different models. In the following paragraphs, the principle of a load-based test is explained using the example of air-to-air units. However, the same concept applies to hydronic heat pumps using air, brine or water on the source side and water on the sink side.

In the load-based test, as in a fixed-condition rating test, the process is conducted using two psychrometric chambers, with one of these chambers called the "outdoor room" where the outdoor unit is placed, with carefully controlled temperature and humidity that represent the various outdoor conditions at which the

unit is tested. The laboratory setup of the outdoor room uses reconditioning equipment controlled by computer software to maintain those conditions for the duration of a test condition, before moving on to the next condition.

In both load-based and fixed-compressor speed testing, the second psychrometric chamber, called the “indoor room” is where the indoor unit is installed. Understanding the different control strategies for the indoor room is the key to understanding the load-based test. In a fixed-condition lab test, the tested unit will run in a steady-state mode that is defined by the particular test condition and typically uses a proprietary “test mode” that overrides the unit’s normal control sequences. The indoor room reconditioning system maintains the indoor room temperature and humidity in a steady-state manner for the duration of the test. The computer software controlling the test measures how much heat the tested unit is producing (in heating mode) or removing (in cooling mode), as well as the energy input and other key parameters (such as air flow).

By comparison, in a load-based test, the indoor room condition mimics (or “emulates”) the condition of a room or space that would be heated (and cooled) by the tested unit in response to a heating or cooling load. The loads are carefully chosen to represent a typical house or indoor space, based on the rated heating or cooling capacity (the size) of the heat pump. The lab software controlling the reconditioning equipment is programmed with the indoor room “load” to be imposed, and it continuously senses the amount of heat the tested unit delivers (or removes) from the indoor test room. Based on these values, it updates the actual indoor room temperature every few seconds to simulate an actual load. The tested unit then responds to changes in the indoor room temperature by turning on or off, or changing its output to match the load, according to its own internal logic (using the same control logic it would use in a typical field installation). This is best understood graphically, as follows:

- Figure 1.3.1-1 shows a simplified example of what would happen in the indoor room during a virtual heating load if the tested unit was not running. The test control software senses the output of the unit, and it causes the room to cool off. In this theoretical example, it loses 50 °F over an hour’s time.
- In Figure 1.3.1-2, imagine that the tested unit is continuously producing half of the needed heat. The room temperature drops at half the rate of that in Figure 1.3.1-1, losing only 25 °F in an hour. (In reality, the temperature drop is not a straight line, but it is simplified here for illustrative purposes).
- Figure 1.3.1-3 shows the temperature of the indoor room if the tested unit continuously generates exactly the amount of heat needed to keep up with the simulated heating load: the temperature stays constant throughout. The controls of a variable-speed heat pump should operate this way, if the virtual load is within the range at which that the unit can operate (i.e., between its maximum and minimum capacity), at the outdoor temperature condition in the outdoor room; but a small amount of variation in indoor temperature will always occur in order for the unit to respond accordingly.



Figure 1.3.1-1. No heat added (Time in minutes)

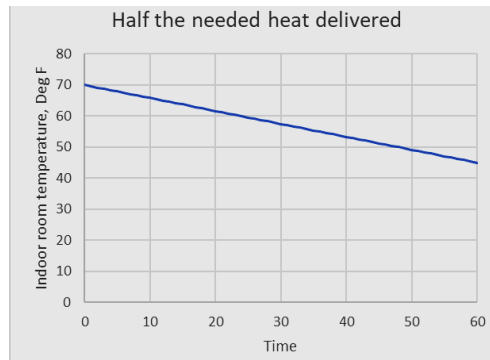

Figure 1.3.1-2. Half the needed heat, temperature drops more slowly (Time in minutes)

Figure 1.3.1-4 is more typical of a real modulation of a tested unit. Imagine at time = 0, the thermostat is turned on at 70 °F, just as the indoor temperature begins at 70 °F, simulating a heating condition in cold weather. As the unit comes on and produces more heat than is needed, the room temperature will increase based on the test control programming. Then, at some point, the internal controls of the tested unit sense that the room is too warm, at which point it will reduce its output (in this example, at minute 8). The lab control software senses the unit having reduced output, and causes the room temperature to drop again, as it would under a real heating load. At some point (in this case, below 69 °F) the internal controls of the tested unit turn the unit back to a higher heating output (in this example, at minute 10), and the cycle continues.

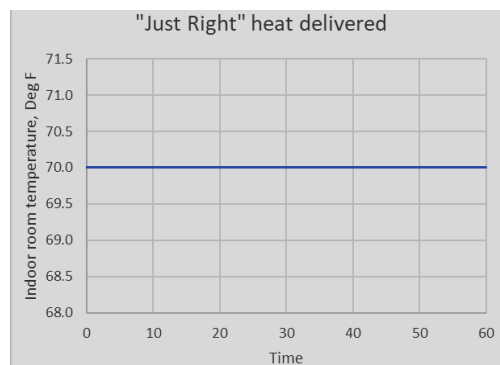

Figure 1.3.1-3. Heat added is correct, stable temperature (Time in minutes)

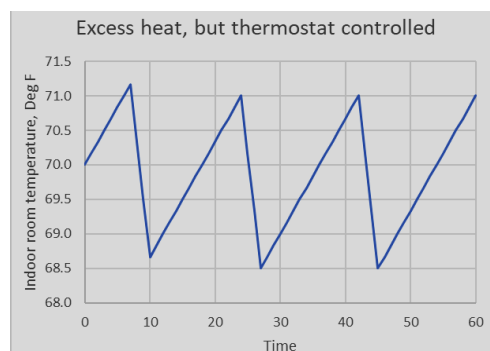

Figure 1.3.1-4. Heat modulates, temperature controlled by thermostat of tested unit (Time in minutes)

Thus, the tested unit is responding to an indoor condition that simulates a heating (or cooling) load that would be found in a house or room that is exposed to the same conditions as the outdoor room where the outdoor unit is located. Although the lab control software and reconditioning equipment is literally controlling the indoor room temperature, the temperature is based on the response of the tested unit just as if it was in a space that was heating up or cooling off in response to a real load.

In an actual test, the behaviour of the lab and the system being tested is, of course, more complicated than what is shown in Figures 1.3.1-4. In some cases, variable speed systems can match the heating or cooling

requirement closely (such as in Figure 1.3.1-3) with natural variations based on the unit's internal controls, as it responds to the virtual load.

However, variable speed systems cannot ramp "down" continuously, all the way to "off"; they always have a lower limit of heating or cooling output. When the load is smaller than that minimum, the unit will have to cycle on and off, which affects the operating efficiency. In the highest load conditions (when outdoor temperatures are also the most extreme), it is expected that tested units will typically lack the heating or cooling output needed to maintain the steady state indoor temperature target. For those test conditions, the unit is set instead to run at full capacity (but still under its normal controls), and the rest of the test is completed while the reconditioning equipment keeps the indoor room under steady state conditions.

In each test condition, the lab software collects data to verify both the heating or cooling output of the tested unit in real time, and to measure the electricity input (power). Sometimes this "steady state" operation over time occurs naturally (as typified by Figure 1.3.1-3). However, during the load-based test, the indoor room conditions vary over time, causing the heating or cooling output to also vary in more complex ways. This may be due to the need to cycle off during low-load conditions because the variable-speed controls are "searching" for the right output to best match the load; the need for defrost cycles in some heating conditions; or for other reasons dictated by the internal control logic of the tested unit.

These general considerations exemplify how the control system and its interaction with the building features and thermal loads define a broad spectrum of possible operating performance.

Load-based tests respond to the necessity of capturing the main characteristics of actual operating performance during laboratory tests while minimising additional effort and cost when compared to current standards.

Newly proposed testing methodologies (Category B) aim to reflect the following aspects:

- Unit performance when operated under its native control and using its own thermostat.
- Characterise efficiency losses or gains of variable speed units (inefficiency of cycling operation and assess the efficiency of the control method).
- Integrate all cycles within a test bin such that defrost cycles, on/off cycles, etc. are directly measured within each temperature bin.
- Capture the interaction of the system operation with the actual load scenario and the thermal features of a representative building.
- Prevent the manufacturer from artificially inflating the unit efficiency during performance rating tests.

The characterisation of these aspects should drive positive developments in the design of efficient control strategies for variable speed units and maximise efficiency during the field operation of heat pump installations.

The proposals developed by 4 independent institutes are reviewed with reference to the following aspects:

- Scope of the test. Including target equipment type and capacity.
- Test conditions.
- Building-side thermal emulation method.
- Analysis of repeatability, reproducibility, and representativeness (3Rs).

Table 1.3-1 provides a first summary of the testing methodologies.

Table 1.3-1. Summary of the reviewed test procedures for the development of Category B Standards

Test method (institution)	Test scope	Heating conditions	Cooling conditions	Building thermal inertia	3Rs analysis
Waseda University	Emulator-type load-based test for air-to-air units	2 tests defined consistently with JIS B 8515 for heating operation *partial-load at 25% of max capacity **(tentative)	3 tests defined consistently with JIS B 8515 for heating operation *partial-load at 25% of max capacity **(tentative)	Defined within the lumped parameter emulator by the values of thermal and moisture inertia	Repeatability (completed) Reproducibility (Cooling tests completed, Heating tests ongoing) Representativeness (ongoing)
CSA	SPE-07:23 load-based and climate-specific test for air-to-air units (using emulator)	5 temperatures (-15 to 12.2C) plus one additional test for marine climate zone as well as optional test at lowest operating temp	4 temperatures (25 to 40C) plus one additional test for hot, dry climate zone	Simulated thermal capacitance (sensible and latent) of building interior included in load calculation	Repeatability (completed) Reproducibility (ongoing) Representativeness (completed)
BRI / Better Living	Load-based test for VRF air-to-air units	OC: 7C (DBT) 6C (WBT) IC: 20C (DBT) 15C (WBT)	OC: 35C (DBT) 24C (WBT) IC: 27C (DBT) 19C (WBT)	Artificial thermal capacitance (sensible and latent)	Repeatability (ongoing) Reproducibility (ongoing) Representativeness (ongoing)
BAM and RWTH	Load-based test for hydronic heat pumps	5 or 6 outdoor temperatures in accordance with EN 14825:2022	Not applied yet (ongoing)	Defined within a simplified building model	Repeatability (completed) Reproducibility (ongoing) Representativeness (ongoing)
RWTH	Hardware in the Loop (HiL) for building energy systems with hydronic heat pumps	Outdoor conditions defined by weather data. Use reference days (~4 days) representing a whole year for a specific geographical location	See heating conditions. Depending on location, some days have cooling demand	Simulated by detailed Modelica model of a specific building and transfer system to be studied	Repeatability (completed) Reproducibility (completed) Representativeness (ongoing)

1.3.2 Emulator-type load-based testing method for air conditioners by Waseda University

This section describes a testing method for residential and commercial air conditioners that can reproducibly assess the energy efficiency of variable speed units and characterise their controllability when operated according to their native control under load scenarios representative of in-field installations. The proposed method essentially relies on a standard air-enthalpy testing facility used for more conventional testing and does not require additional instrumentation and testing time requirements, but only the bidirectional inter-connection of a simple simulation software, which acquire the real-time measurement of the supplied capacity from the instrumentation of the tested unit, and also controls the reconditioning unit of the indoor psychrometric room.

1.3.2.1 Overview

The research efforts of Waseda University in the development and evaluation of optimal control strategies for air-to-air vapor compression systems led to a first national project conducted between 2014-2016 for the development of a new testing method able to reproducibly capture the control response of variable speed drive units and correspondingly assess their performance.

This pioneering project resulted in the design, construction, and operation of a first prototype (Ban et al., 2016, 2017). These preliminary results were critical for recognising the main challenges related to the hardware and instrumentation of current air-enthalpy testing facilities in the real-time measurement and dynamic control of the reconditioning unit during dynamic system operation. The necessity of high-accuracy instrumentation and appropriate controllability of the reconditioning unit was recognised and dealt with for developing the testing method reported in Giannetti et al. (Giannetti et al., 2022a,b).

1.3.2.2 Conceptual description of the testing method

As reviewed in Section 1.2, current rating standards rely on forcibly achieved steady-state tests where the native control of the system is deactivated. To assess the energy efficiency of variable speed units when operated according to their native control under load scenarios representative of in-field installations, the emulator-type load-based testing method combines numerical software (room emulator) with the hardware of a conventional testing facility used for category A standards. The software and hardware are interfaced through the reconditioning unit (or “condition generator”), which recreates the modulations of the room conditions as calculated by the emulator, and the “measuring chamber”, which feeds real-time measurements of the cooling capacity supplied by the indoor unit as a digital signal to the emulator, as described in Clause 1.3.1. A schematic representation of this testing method is illustrated in Figure 1.3.2-1.

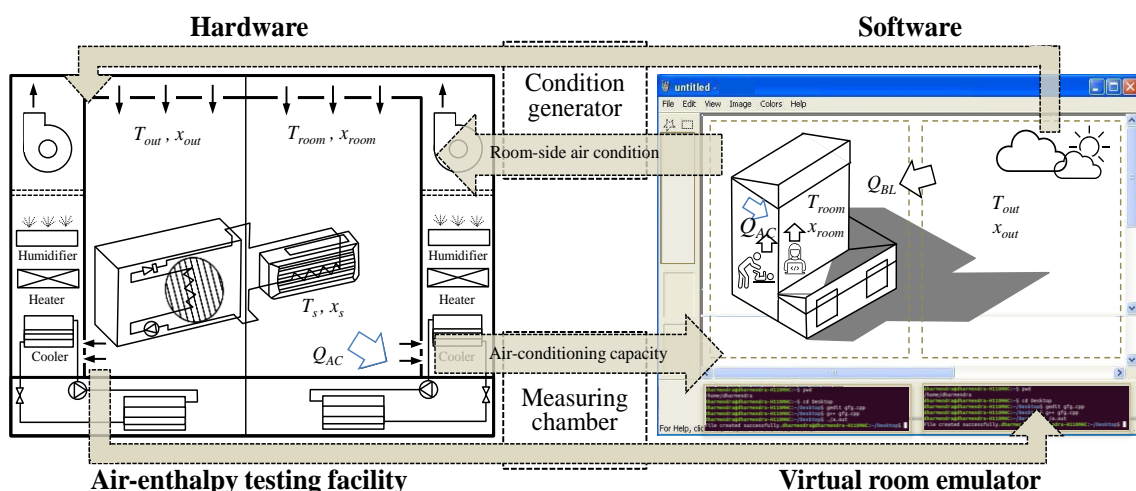

Figure 1.3.2-1. representation of the emulator-type load-based testing methodology (Giannetti et al, 2024)

1.3.2.3 How the tested system is operated

As explained in Section 1.3.1, load-based emulator-type tests are conducted while installing indoor and outdoor units in two separate psychrometric chambers and allowing the system to operate in accordance with its native control. The emulator software calculates the modulations of the indoor air condition while accounting for the dynamic response of the tested system. Complementarily, the reconditioning unit of the psychrometric chamber is controlled to replicate such numerical results in terms of temperature and humidity of the return air to the indoor unit. The system attempts achieving the indoor set temperature for the simulated load scenario and may experience indoor temperature and humidity modulations of the return air to the indoor unit due to variable-speed or on/off cycling operation.

In practice, the use of the emulator software can dynamically generate reproducible testing conditions by controlling the reconditioning unit to make the test independent of the specific thermal features of the testing facility. Meanwhile, temperature and humidity conditions in the outdoor psychrometric room are held constant.

Given the dynamic characteristics of emulator-type load-based tests, a preliminary investigation of the factors affecting measurement error and delay, such as the computational time delay of the emulator, trackability of temperature and humidity in the condition generator and in the measuring chamber, and time delay of the sensors, was carried out (Giannetti et al., 2022b) and represents the basis for reliably defining the level of reproducibility of such tests. Additionally, to minimise the loss of information between software and hardware sections, a tuneable feed-forward compensation module (FFC) was developed using a transfer function system identification approach (Figure 1.3.2-2). This software module may be used to restrain the delay in the reconditioning within the allowable range for enhancing the reproducibility of the test results across different testing facilities (Giannetti et al., 2024).

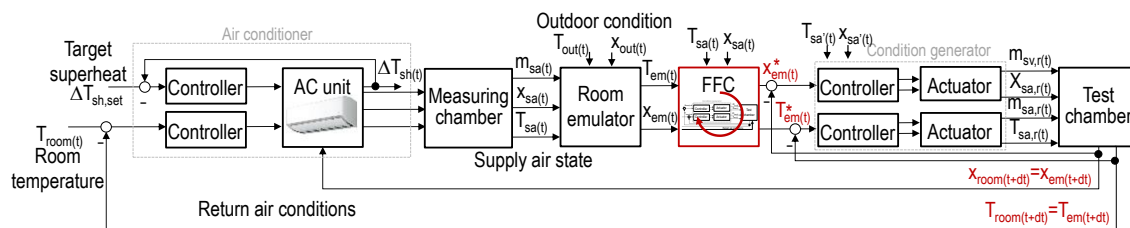

Figure 1.3.2-2. Schematic block-diagram of the emulator-type load-based testing methodology (Giannetti et al., 2024)

1.3.2.4 Illustrative test results

Tests were conducted at corresponding ambient and partial load conditions with the same unit operating according to the current JIS standard [JIS B 8616 (2015a)] and with the emulator-type load-based testing method to characterise the gap between actual system performance and performance recorded with current testing standards. Fig. 1.3.2.3 exemplifies the results obtained at a partial load ratio of 25%. In this case, the air conditioner functions in a cyclic on-off operation when operated with its own native control and exhibits a COP of 5.58, while the fixed-compressor-speed test indicates a COP of 7.13.

Consequently, when testing the system with the emulator-type load-based testing method and setting the building load above 50% of the rated system capacity, the native control could achieve steady-state operation for a virtual room size of 147 m³. However, minor dynamic modulations of the compressor speed were observed because of oil recirculation manoeuvres (Miyaoaka et al., 2023). Conversely, under lower building load conditions, the system responded with on-off cyclic and variable-speed operations. Figures 1.3.2-4 (i)-(ii) illustrate the operation encountered when the building load was set to 30%. The lumped heat capacity of the virtual room was changed according to the size of the room (Togasi&Tanabe, 2009), and the on-off cycling operation of the air conditioner showed different cycling intervals. These results provided evidence for the significance of the building thermal inertia on the system controllability and corresponding performance, and for the necessity of a virtual room emulator for fairly assessing the dynamic performance of air conditioners while equivalently reproducing the “room-side air condition” in different testing facilities. Smaller size

rooms correspond to faster cycling and larger efficiency losses, while a larger room thermal inertia allows the control system to operate with longer cycling and reach pseudo-steady operating intervals with lower cycling losses.

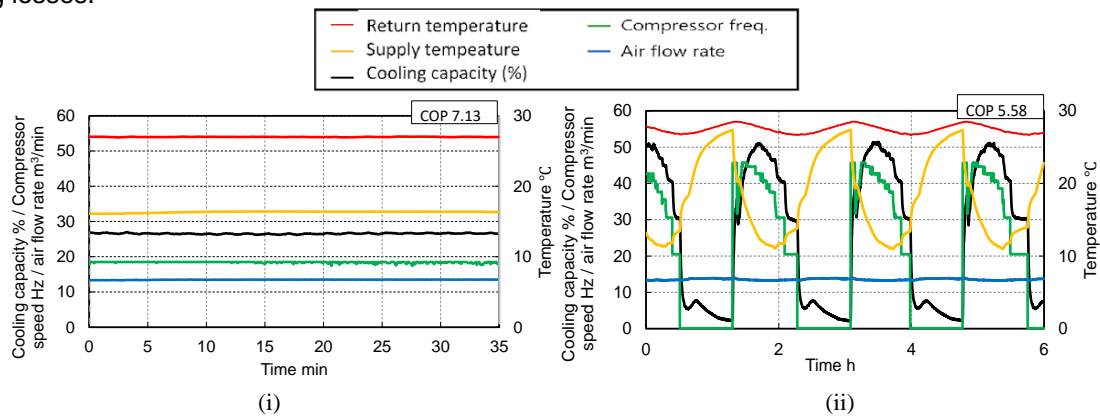

Fig. 1.3.2-3. 25% Partial load performance (i) JIS standard test (ii) emulator-type load-based test (Giannetti et al, 2022b)

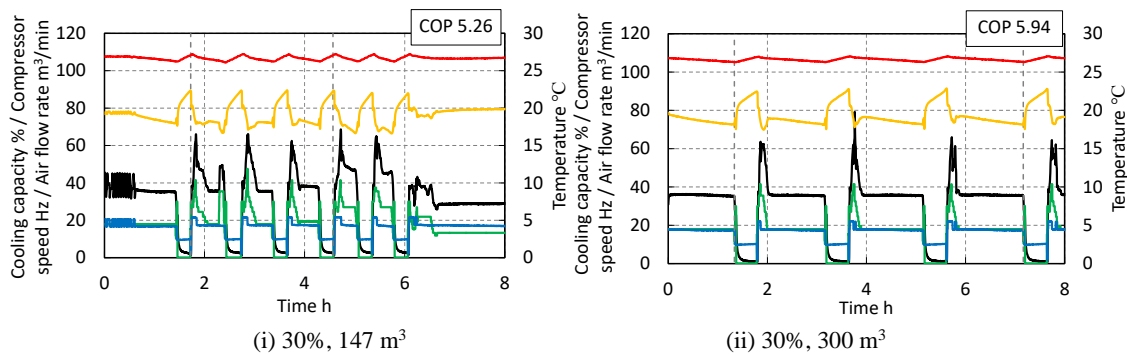

Figure 1.3.2-4. 30% Partial load tests with (i) 147 m³ (ii) 300 m³ virtual room size (Giannetti et al, 2022b)

1.3.2.5 Selection of set of test conditions

Full load and part load operating conditions presently refer to JIS B 8615 (JIS, 2015c); including 3 operating points for cooling and 2 for heating operation. Adjustments of the selected tested conditions are presently under consideration to capture cycling operation (part-load condition at 25% of maximum capacity) and minimise extrapolation in energy calculation procedures, effectively capture control characteristics, and harmonise test requirements along with test condition for maximising comparability and minimising testing burden. Additionally, pre-defined continuous load patterns are under consideration for test automation.

1.3.2.6 Assessment of repeatability, reproducibility, and representativeness of the test results

Evidence for repeatability and reproducibility properties of the emulator-type load-based tests are essential for defining new standards for performance ratings. Dedicated investigations with multiple tests repeated within the same testing facility (Miyaoaka et al., 2023) and expanded to four different testing facilities (Dondini et al, 2024), demonstrated results repeatability within 1.5% and reproducibility within 3% standard deviation, respectively.

Table 1.3.2-1. Test conditions of round robin tests from Dondini et al. (Dondini et al, 2024).

Conditions	Indoor dry-bulb temp. (°C)	Outdoor dry-bulb temp. (°C)	Outdoor wet-bulb temp. (°C)	Load Ratio (%)	Simulated room size (m³)
Low load virtual room 1	27	29	19	25	147
Low load virtual room 2	27	29	19	25	75
Mid load virtual room 1	27	29	19	50	147

Specifically, the performance and control response (such as those illustrated in Figure 1.3.2-5) of a 10-kW R32 ceiling-type unit, operated in cooling mode within the four facilities at the test conditions reported in Table 1.3-1, were analysed to provide a first assessment of the level of reproducibility of the proposed testing method and suggest challenges and possible improvements. The results from all testing facilities demonstrated consistent performance and control responses (as summarised in Table 1.3.2-2).

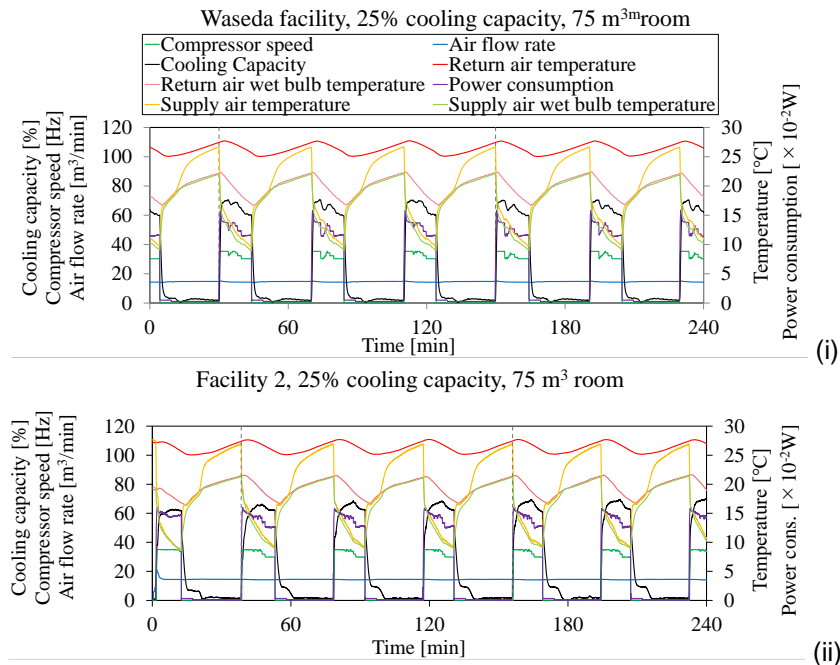

Figure 1.3.2-5. Test results for “Low load virtual room 2” at 25% load, 27°C indoor set temperature, and 75 m³ for: (i) Waseda, (ii) Facility 2 (Dondini et al, 2024)

Table 1.3.2-2. Summary of Round robin test results (Dondini et al, 2024)

Conditions	COP Waseda	COP Facility 2	COP Facility 3	COP Facility 4	Deviation from average
Low load virtual room 1	5.34	5.57	5.39	5.33	3.01 %
Low load virtual room 2	5.37	5.22	5.23	5.30	1.70 %
Mid load virtual room 1	6.24	6.10	6.04	6.03	2.25 %

1.3.2.7 Definition of seasonal or annual performance indices, and system performance metrics

Seasonal efficiency calculation presently refers to JIS C 9612 (JIS, 2013), which combines the hourly distribution of ambient temperature, regional heating and cooling loads to calculate the APF index. As emulator-type load-based tests characterise the system performance and controllability when operated according to their native control, such seasonal index may provide closer representations of the actual field performance of air conditioners and may drive virtuous developments of efficient control, as well as a method to verify control strategy improvements. Additionally, the performance characterisation extracted through this testing method is being used to construct performance curves and maps for performing seasonal energy calculations.

1.3.3 CSA SPE-07:23 Load-based and climate-specific testing and rating procedures for heat pumps and air conditioners

1.3.3.1 Background

In 2015, the Canadian Standards Association (CSA) began work on a test and rating procedure that would better represent installed performance of variable capacity heat pumps (VCHPs) in a range of climates. In 2019, the Canadian Standards Association (CSA) published a technical review version called EXP-07:19, *Load-based and climate-specific testing and rating procedures for heat pumps and air conditioners*, (referred to as EXP07).⁹ After conducting numerous additional lab tests using EXP07 and soliciting public comments, a final revision was made and published as SPE-07:23 (CSA, 2023a) using the same title (hereafter SPE07). SPE07 uses load-based tests at a range of conditions of both heating and cooling operation in order to create a performance profile, which is then used to calculate a set of Seasonal Coefficient of Performance (SCOP) values. These SCOPs are reported separately for heating and cooling for seven different North American climates and represent an estimate of net seasonal efficiency of heat pumps in typical residential applications for each of those climates.

The scope of SPE07 applies to residential, single-zone air-to-air heat pumps and air conditioners less than 65k Btu/h (19 kW) in capacity.

This section provides an overview of how SPE07 works and generally explains the concepts behind the SPE07 rating procedure. It is adapted from the *EXP07 Plain Language Guide* (CSA, 2023b).

1.3.3.2 Load-based Testing

Most fundamental to SPE07 is its approach to testing using a "virtual" or simulated building load, managed by test room system software (sometimes referred to as an "emulator"). As described in Section 1.3.1, SPE07 uses a dynamically-controlled, load-based approach that measures heat pump performance across a wide range of outdoor temperatures, while the system meets heating and cooling loads that are typical for residential applications, using its own thermostat and internal control logic to respond to changes in the room temperature.

The approach taken in SPE07 is very similar to that outlined in Clauses 1.3.2 and 1.3.4, and to a lesser extent 1.3.5 (although all four methods have the same intent to emulate operation of the heat pump under its native control system rather than operation in a special test mode). However, SPE07 differs from the others because it is a published test method that includes both test procedures and performance rating calculations.

To account for the natural variation in the unit operation, the test procedure includes detailed instructions so that the lab can determine at what point during a particular test condition the test may be considered "complete". This process is defined by a set of rules that require monitoring the heating or cooling output and electric input over time, searching for a during which these measurements are steady, or repeating over time in such a way that additional measurements will not likely change the result in a meaningful way. This is referred to as "convergence", and once convergence (or a test period time limit) is reached, the test condition is considered complete and the test procedure moves to the next condition, until all tests are completed.

1.3.3.3 The Load Line

During SPE-07 lab testing, two series of heating tests (Continental and Marine), and two series of cooling tests (Humid and Dry) are conducted (as described below). Each climate-based rating is derived from those test results using the appropriate set of heating and cooling tests, mapped into that climate data. For heating, SPE-07 uses a single, linear relationship between outdoor temperature and load, based on the rated capacity of the tested equipment (referred to as a "load line"). The load line is a typical generalised building load profile, and the concept is common to other heat pump rating systems such as AHRI 210/240 (AHRI, 2023) and CSA C656 (CSA, 2014). A single load line is used for the heating load in SPE-07 (CSA, 2023a); this is based on the rated cooling capacity at 95F. The load increases with decreasing

outdoor temperature, and the no-load point (intersection with the x-axis) occurs at 60F by definition. The Marine climate zone heating test conditions vary only by the outdoor unit humidity that is used. For cooling, separate load lines are defined for dry and humid conditions, which are then used to generate the cooling SCOP ratings.

Each chosen load line implies an assumed relationship between the size of the equipment and the magnitude of the building load – that is, an implied “equipment sizing”. Defining the “right” load line is a challenge because home efficiency levels vary dramatically, and the relative sizes of a home’s heating and cooling design loads can vary significantly. Even within a given building, loads can vary significantly off of the “average” load line due to transient events, such as changes in solar gain. The SPE-07 (CSA, 2023a) heating load line is used for all the heating climate seasonal ratings. Even though heating design temperatures vary significantly from mild to cold climates, the chosen load line is a compromise that reduces the number of required lab tests while remaining broadly relevant across a range of climates. It generally results in the testing of heat pumps under the full range of operating modes, including cycling, modulating, and full-load, which is an objective of the test procedure.

An analysis of alternative load lines to that used in SPE-07 (CSA, 2023a) was conducted and it concluded that the SPE-07 load line remained robust under a variety of circumstances, except for the extreme case of sizing a heat pump for full-load heating in the Subarctic and Very Cold climate zones. In this case, it was suggested that some additional metric such as cold-ambient capacity maintenance would also be required – especially if the objective is to reduce reliance on auxiliary heat sources (and such a metric has indeed been used in incentive and manufacturer challenge programs in Canada and the United States²).

Learning Test Cycle

Before proceeding with the cooling and heating rating test series, a learning test series is conducted. The learning test series allows the equipment to run under its own controls and acts as a “break-in” period.

1.3.3.4 Test Conditions

The SPE07 test procedure uses 6 heating conditions and 10 cooling conditions. The tests are run at each condition until the system achieves convergence, as outlined above. At each outdoor temperature, the amount of heating or cooling load that is dynamically simulated in the indoor room (see “the load line” above) is appropriate for the outdoor temperature at which the equipment is tested and is also scaled to the capacity of the tested unit, so that each unit is tested based on its rated capacity.

The heating conditions are divided into two general climate areas, Continental and Marine, each with its own sequence of outdoor temperatures and corresponding loads. The cooling test conditions are divided into humid and dry climate areas, each with its own sequence. In addition, in the humid cooling tests, a dynamic moisture load is applied by monitoring the removal of humidity by the equipment under test, and then updating the indoor humidity in the test room programming. This works in very much the same way that the dynamic heating and cooling loads are applied to indoor temperature for all the tests, and it allows the test to measure how well the units remove moisture in the humid cooling tests. (By contrast, in a conventional test the reconditioning equipment maintains a constant humidity level in the indoor room). Table 1.3.3-1 summarises the four test sequences:

² In Canada, the Canada Greener Homes Grant Initiative, as a condition of eligibility for its cold climate heat pump grant amount, required an equipment capacity maintenance (Max -15 ° C (5 ° F)/Rated 8.3 ° C (47 ° F)) ≥ 70% (with a COP ≥ 1.8). In the US Department of Energy Cold Climate Heat Pump Challenge, the performance requirement at 5F (-15C) was to maintain 100% of the nominal capacity of the system as tested at the AHRI 210/240 Appendix M1 A2 test point for heating/cooling heat pumps (with a COP ≥ 2.4 for equipment up to 4 tons and ≥ 2.1 for equipment > 4 tons).

Table 1.3.3-1. Summary of the four test sequences.

Heating	Outdoor Conditions	Indoor Conditions
Continental	5 temperatures from 5 to 54 °F (-15 to 12.2 °C) , plus optional test at lowest operating temp, per manufacturer	70 °F (21.1 °C) 56% RH max
Marine	One additional at 34°F (1.1°C)	
Cooling	Outdoor Conditions	Indoor Conditions
Dry	5 from 77 to 113 °F (25 to 45 °C)	79 °F (26.1 °C) 21% RH max
Humid	4 from 77 to 104 °F (25 to 40 °C)	74 °F (23.3 °C) 55% RH max

Wherever possible, test procedures, such as measurement techniques, are harmonised with AHRI 210/240. Although the indoor unit air flows during SPE07 tests may vary based on the internal controls of the tested unit, the initial setup to define and measure full-load air flows, and to establish static pressures for ducted systems, are harmonised with conventional test methods.

1.3.3.5 Efficiency Metrics

Once the test results have been measured and recorded, seasonal efficiency values are calculated. The result is a heating and a cooling Seasonal Coefficient of Performance (SCOP) for each climate zone – SCOP_h and SCOP_c. (Except that there is no cooling SCOP for the Subarctic zone.) The basic method to calculate seasonal efficiencies is called a bin model, consistent with other rating and common HVAC engineering analyses. For each climate, the analysis uses a specific number of hours that represent the number of heating or cooling hours at each temperature “bin” throughout the heating and cooling seasons. The temperature “bins” are divided into increments of 5 °F (2.8 °C), and the unit’s heating or cooling efficiency, as determined in the lab, is applied to each bin based on the number of hours within that bin. The size of the heating and cooling loads used for the rating calculation are the same as those used during the tests. For heating, at any outdoor temperatures for which the tested unit does not have enough heating capacity to meet the full heating load, it is assumed that the difference is made up with electric resistance supplemental heaters with a COP of 1.

For each climate, the total delivered output for the season is divided by the total electrical input to determine the Seasonal Coefficient of Performance (SCOP) for that unit in that climate. The SCOP is a simple ratio, so a COP of 1.0 represents 100% efficiency (such as electric resistance heat). Heating SCOPs are generally higher in warmer climates and lower in colder climates, and cooling SCOPs are generally lower in the hottest climates and increase as summer climates get cooler. The eight representative climate zones are shown in Figure 1.3.3-1.

There is a provision that the lab tests the energy input during “standby” modes of operation (when the unit is not heating or cooling), as a separate procedure. The results are used in the analysis for seasonal COP, which may be reported separately with and without the standby power. The standby power is added for hours (based on each climate), during heating or cooling seasons, for temperatures at which there is no heating or cooling requirement but when the HVAC system unit thermostat is likely to remain in “heat” or “cool” mode. Also, standby power is applied to shoulder periods when there is no heating or cooling demand, and the unit controls are likely to be turned “off,” but the system is still powered on at the circuit panel. Standby energy makes a more significant impact on annual efficiency ratings in climates with long shoulder periods that require no heating or cooling, and of course, for equipment that has higher standby electric energy input.

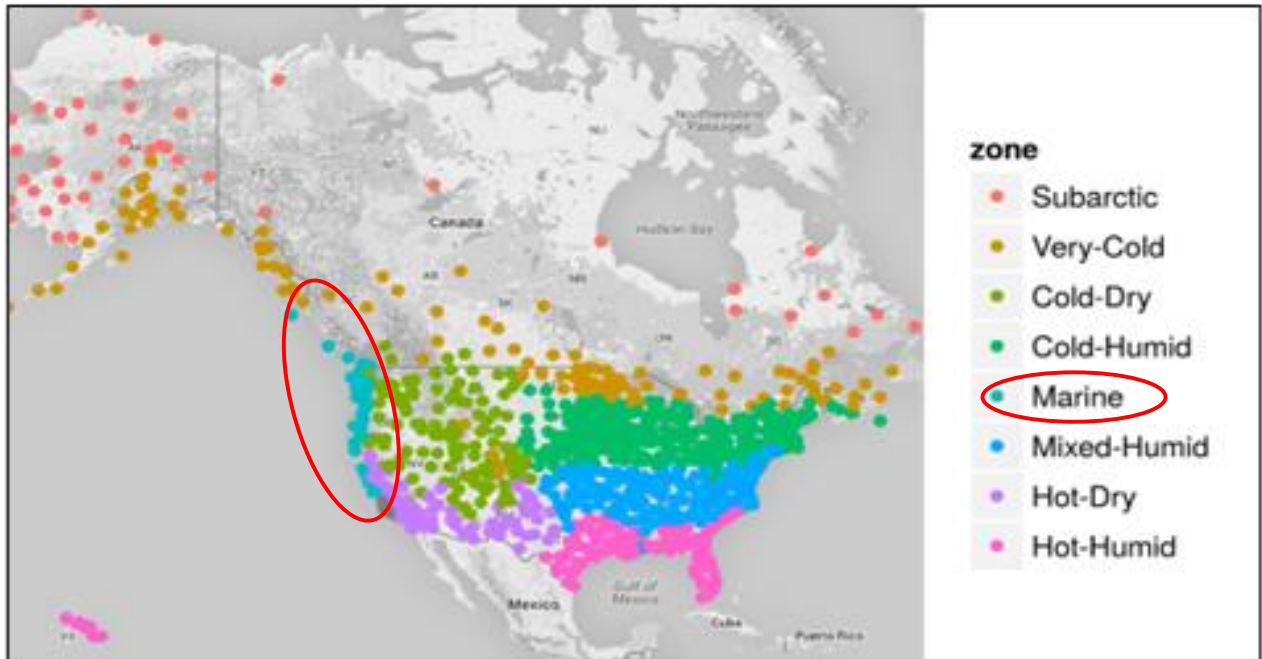

Figure 1.3.3-1. SPE07 Representative Climates ³

1.3.3.6 Application Ratings

Besides the standard climates and heating and cooling load conditions, Annex F of SPE07 provides alternative rating calculation methods called “Application ratings” so that users can vary the conditions used in the model in a predictable, standardised manner. This allows a designer or analyst to use a specific climate rather than one of the eight prototype climates. It also allows for equipment loads (heating and/or cooling) that vary from the ones used in the test, and for specification of auxiliary heat sources that have a fixed heating output, whether electric or some other fuel. For an application rating, details are provided on how such a result needs to be reported so that the application-specific conditions are properly disclosed.

1.3.3.7 System Performance Metrics

Improved climate-specific metrics such as SCOP provide a mechanism for energy efficiency incentive programs to estimate savings for specific heat pump models appropriate for various climates. Better predictions of performance, using SCOP values based on tests conducted with native controls, will allow programs to more accurately attribute value for incentives and other support, to better match targets for savings to the systems with the highest efficiencies. Load-based test procedures and ratings such as SPE07 should also improve understanding by designers and consumers about the value of various products.

1.3.3.8 Repeatability, Representativeness and Reproducibility

In 2022-2023, a research project organised by the Northeast Energy Efficiency Partnerships (NEEP) and sponsored by many US and Canadian organisations has measured performance of six heat pumps in the field and also in the lab, using both AHRI 210/240 (category A) and SPE07 (Category B) methods, with the purpose of assessing the representativeness of “real” field operation of each laboratory test method. The six heat pumps were installed in three identical (unoccupied), calibrated manufactured homes in Nebraska (US). They were monitored in cooling and heating operation from Aug 2022 to March 2023. The details of the field phase are published in (NEEP, 2023a) and summarised in Harley et al. (Harley et al., 2023) After the field data collection, the six units were tested by a lab that has much experience using SPE07, to compare the field performance with the reported efficiency metrics from the two test methods. The conclusion is that SPE07 is more representative, although there was more low bias in the cooling rating using

³ The Marine climate is circled for clarity to differentiate it from climates shown in similar colors.

SPE07 than expected. A summary of the results is shown in Table 1.3.3-2 and Figure 1.3.3-2. In all cases, the field data and the M1 (which is related to the conditions of AHRI210/240 results) are both normalised to the same climate used in SPE07 to ensure they are comparable. This is explained in the cited papers.

Table 1.3.3-2. The root mean squared errors (RMSE) and mean absolute percent errors (MAPE) for SPE-07 and M1, using field SCOP as a reference.

	Cooling RMSE		Heating RMSE		Cooling MAPE		Heating MAPE	
	SPE07	M1	SPE07	M1	SPE07	M1	SPE07	M1
Ducted	0.74	0.45	0.26	0.40	13%	9%	11%	17%
Ductless	0.92	2.14	0.20	1.39	13%	43%	10%	64%
Combined	0.82	1.40	0.24	0.93	13%	22%	10%	36%

In the end, there were only five units with valid data for the comparison, three ducted and two ductless. In all cases for the entire group, the SPE07 errors are smaller, although when looking at the ducted and ductless subgroups, the errors were larger for SPE07 in the ducted group for cooling. The sample size is tiny, however, to generalise the results to ducted and ductless units.

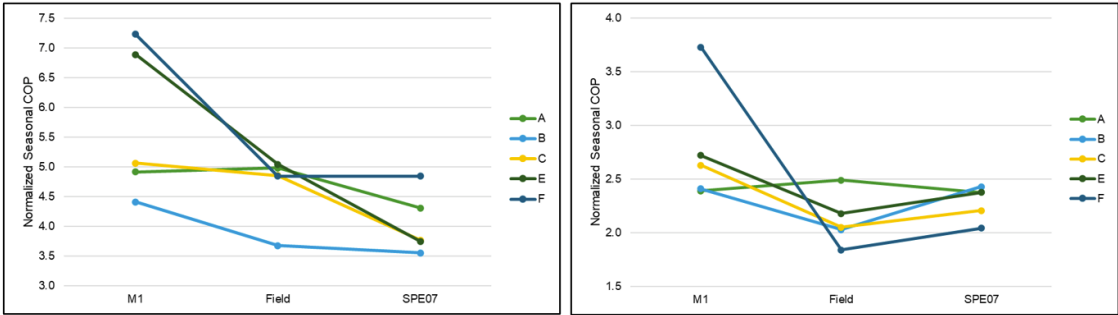

Figure 1.3.3-2. Normalized seasonal COP for M1, field, and SPE07 for cooling (left) and heating (right)

Figure 1.3.3-2 shows a visual representation of the normalised results. Here, the low bias of SPE07 in cooling is apparent (4 of the 5 units), and the more extreme over-statement of efficiency of M1 (AHRI 210/240) for some units in both cooling and heating can be seen. Further details of this study are awaiting publication but should be found in NEEP (NEEP, 2023b) and Harley et al.(Harely et al., 2024) .

In addition, during the lab tests of this study, two of the heat pumps have been re-tested to assess repeatability. Along with a previous study on EXP07 by AHRI and Purdue University (Dhilon et al., 2022), this small sample suggests repeatability is within $\pm 3\%$ at a 95% confidence interval. Although in the AHRI assessment, reproducibility was not very good for EXP07, it is expected that it will be improved for SPE07, and a second lab will begin testing two of the units from the NEEP representativeness study shortly after this writing.

1.3.4 Load-based test to obtain relationships between partial load ratio and energy efficiency of VRF systems by Better Living

The purpose of this proposed test protocol is to improve the testing and evaluation of variable refrigerant flow (VRF) systems.

The testing and evaluation of the multi-split system air conditioner and air-to-air heat pump, according to ISO 15042 (ISO, 2017b) and/or JIS B 8615-3 (JIS, 2015c) requires fixing the compressor speed, opening the electronic expansion valves (EEV), and adjusting the unit's set-point to the lowest temperature during cooling or the highest temperature during heating. Currently available products automatically control the compressor speed and electronic expansion valve to maintain a comfortable temperature. This proposed

test protocol evaluates the VRF system by analysing automatic control of compressor speed and electronic expansion valve at different thermal loading.

This proposed test protocol shall be used in conjunction with existing testing and evaluation standards, such as ISO 15042 (ISO, 2017b), JIS B 8615-5 (JIS, 2015c), and BS EN 14511-3:2018 (BSI, 2018), to enhance the realism of testing and evaluation. ISO 15042 (ISO, 2017b), for instance, outlines specific conditions in Section 12.2 of this standard that, when followed, can result in different ratings. Annex F of ISO 15042 (ISO, 2017b) displays the part-load capacity test, and Annex G describes the individual indoor unit capacity tests. To apply this proposed test protocol as additional tests for the VRF system, it is necessary to follow the standards mentioned in (ISO, 2017b), (JIS, 2015c), (BSI, 2018). These standards cover the preparation of the VRF system, the arrangement of the testing facility, the selection and installation of sensors and measuring instruments, and the choice of methods used to measure the parameters needed for data analysis.

1.3.4.1 Terms and Definitions

This proposed test protocol uses the terms and definitions provided in ISO 15042 (ISO, 2017b) and/or JIS B 8615-3 (JIS, 2015c). Additional terms and definitions are introduced based on testing and measurement evaluations conducted by Building Research Institute (BRI) and National Institute for Land and Infrastructure Management (NILIM) (Enteria et al., 2015, 2016, 2017).

- **Thermal capacity** of the indoor unit(s) is measured using the air enthalpy method. The difference lies in the total enthalpy of the supply and return air, which is then multiplied by the mass airflow rate.
- **Balanced thermal capacity ratio** means that each indoor unit has the same thermal capacity.
- **Unbalanced thermal capacity ratio** means that each indoor unit does not have the same thermal capacity.
- **Rated thermal capacity** test measures the heating or cooling capacity of indoor units based on ISO 15042 (ISO, 2017b) and/or JIS B 8615-3 (JIS, 2015c).
- **Real operational control** refers to the control logic of both marketed and installed VRF air-conditioning and heat pump systems.
- **Real thermal capacity test** measures the heating or cooling capacity of indoor units based on the system's operational control.
- **Partial thermal capacity test** measures the capacity at a lower value than the real thermal capacity test.
- **Cyclic operation** happens when the compressor turns on and off, especially when the thermal loading for cooling and heating modes is low. In the case of multi-compressors, one compressor may operate while the other(s) is/are off.
- **Heating-defrosting operation** is melting ice accumulation from the outdoor unit's heat exchanger in a heating-and-defrosting cycle.

1.3.4.2 Responsible Persons

Engineers who test and evaluate VRF systems using the methods described in ISO 15042 (ISO, 2017b) and/or JIS B 8615-3 (JIS, 2015c) shall also use the protocol proposed in this document to test and evaluate these systems. By incorporating the evaluation method mentioned in this test protocol, test engineers shall have less difficulty in testing products than they currently have when using ISO 15042 (ISO, 2017b), JIS B 8615-3 (JIS, 2015c) and/or BS EN 14511-3:2018 (BSI, 2018) This will also ensure that the person testing the VRF system, based on the existing standards and the proposed test protocol mentioned in this document, can easily differentiate, determine commonalities or similarities in the results, and make a final report on the product being tested. Hence, this proposed testing method will evaluate the VRF system based on its actual operational control strategy, not on the manipulated control strategy used in existing testing standards.

1.3.4.3 Capabilities and Description

1.3.4.3.1 Description

The VRF system shall be tested and evaluated according to the procedure outlined in this proposed test protocol. The test protocol tests the VRF system based on the actual product - the operating logic of the compressor and electronic expansion valves are the same as those found in the commercial marketplace. Prior to this, it shall be tested under the rating conditions specified in ISO 15042 (ISO,2017b), JIS B 8615-3 (JIS, 2015c), BS EN 14511-3:2018 (BSI, 2018), or other relevant national standards. The preliminary test based on standards aims to confirm that the new VRF system adheres to the agreed-upon rules and regulations for its development, creation, and performance. The results of the ISO 15042 (ISO,2017b) and JIS B 8615-3 (JIS, 2015c) standards mentioned in the text can be compared with the results of the proposed test protocol described in this document.

A manufacturer of VRF systems or a third party shall test and measure the performance of the VRF systems based on the test and measurement method described in this proposed test protocol. The test can be performed after the completion of testing and performance measurements recommended by ISO 15042 (ISO,2017b), JIS B 8615-3 (JIS, 2015c) and/or other standards. By incorporating the test and measurement procedure described in this proposed test protocol, more information about the actual performance of VRF systems can be gathered and evaluated than can be gathered using existing protocols alone.

1.3.4.3.2 Testing Facility

A company that manufactures VRF systems or a third party is expected to have a facility designated for testing and evaluating the VRF systems, as shown in Figure 1.3.4-1. The design, construction, maintenance and operation of the test facility are expected to follow ISO 15042 (ISO,2017b), JIS B 8615-3 (JIS, 2015c) and other standards. In a test facility, a VRF system shall be tested and evaluated based on the procedures mentioned in this proposed test protocol, with the proper installation of the required sensors that measure the actual performance of the system, as shown in Figure 1.3.4-2.

1.3.4.3.3 Data Measurement

To ensure that the compressor operates continuously and predictably, data for analysis shall be collected at least 20 minutes after observing stability in the VRF system's operation, as outlined in ISO 15042 (ISO,2017b) and/or JIS B 8615-3 (JIS, 2015c). To analyse cyclic compressor operation, data is collected for three cycles (when the compressor is on and off for cooling, heating, and defrosting) after monitoring the stability of the VRF system operation, as outlined in ISO 15042 (ISO,2017b) and/or JIS B 8615-3 (JIS, 2015c).

1.3.4.3.4 Test Conditions

To test a VRF system using the proposed test protocol, the same control strategy currently in use shall be employed. Prior to testing with the proposed test protocol, the system shall be tested according to the rating conditions outlined in ISO 15042 (ISO,2017b) and/or JIS B 8615-3 (JIS, 2015c).

1.3.4.3.5 Thermal Capacities

The thermal capacities of the VRF system are determined using standardised testing and performance evaluation methods outlined in ISO 15042 (ISO,2017b) and/or JIS B 8615-3 (JIS, 2015c). This ensures that the thermal capacities are rated accurately and consistently. The results of the proposed test protocol shall be compared against the testing results based on ISO 15042 (ISO,2017b) and/or JIS B 8615-3 (JIS, 2015c) as a reference.

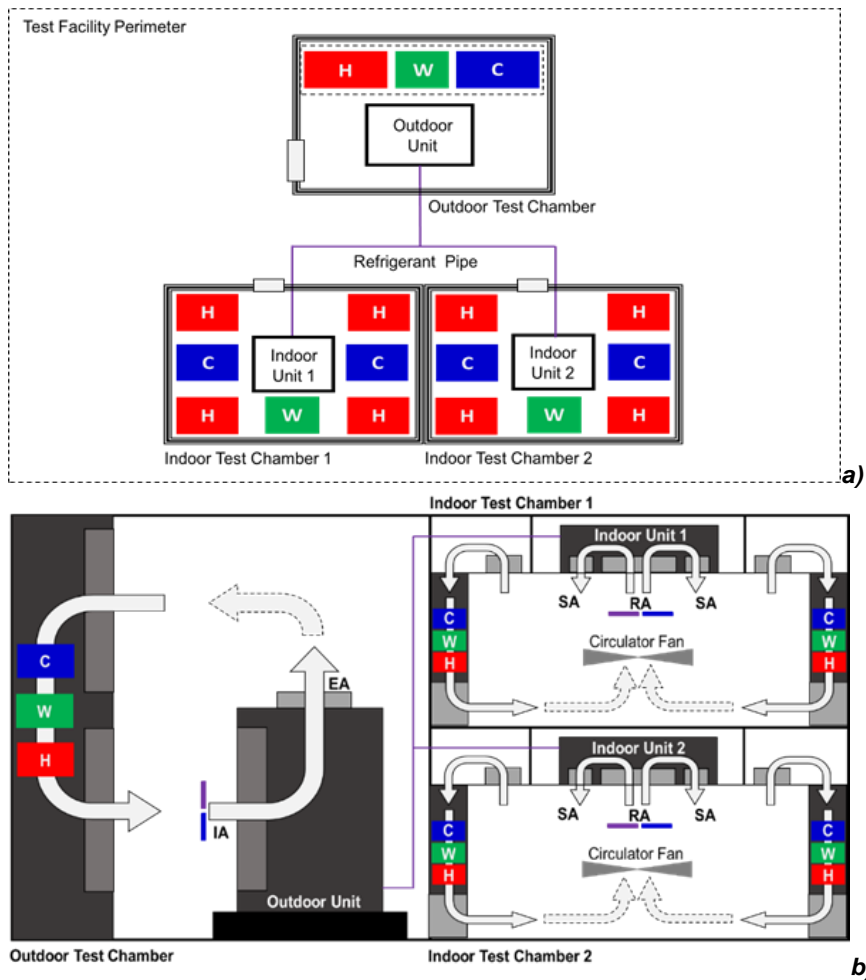

Figure 1.3.4-1. Test facility with one outdoor chamber and two indoor chambers: a) General diagram, and b) Specific diagram. Where H=Heater, C=Cooler, W=Humidifier, SA= Supply air, RA= Return air, IA=Inlet air, EA= Exit air.

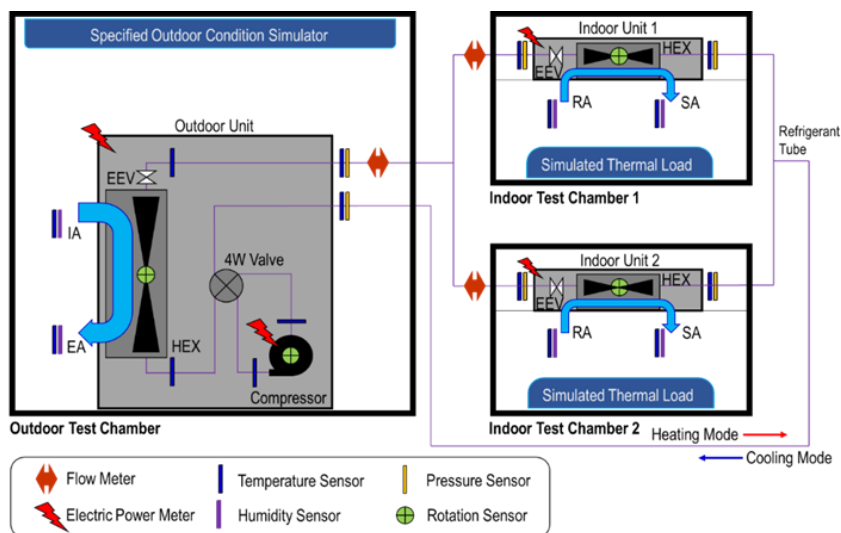

Figure 1.3.4-2. Representational one outdoor unit and two indoor units VRF system with installation and location of important sensors. Where, HEX=Heat exchanger, SA= Supply air, RA= Return air, IA=Inlet air, EA= Exit air.

1.3.4.4 Real Performance Testing

1.3.4.4.1 Outdoor unit

The air flow measurement procedure shall follow the standards set out in ISO 15042 (ISO, 2017b) and/or JIS B 8615-3 (JIS, 2015c). Other standards, such as ISO 5167-1 (ISO, 2022) and ISO 5151 (ISO, 2017a) shall also be consulted when making air flow measurements. In addition, as mentioned in ISO 15042 (ISO, 2017b) and/or JIS B 8615-3 (JIS, 2015c), the instructions given by the manufacturer of the VRF system shall be followed when making air flow measurements.

1.3.4.4.2 Indoor unit

The air flow measurement method used for each indoor unit shall follow the standard method discussed in ISO 15042 (ISO, 2017b) and/or JIS B 8615-3 (JIS, 2015c). Other standards, such as ISO 5167-1 (ISO, 2022), ISO 5151 (ISO, 2017a) and ISO 3966 (ISO, 2020) shall also be consulted. In addition, as mentioned in ISO 15042 (ISO, 2017b) and/or JIS B 8615-3 (JIS, 2015c), the instructions of the manufacturer of the VRF system shall be followed. The air flow rate and noise level suggested by the manufacturer shall be used for testing. This information shall be available in the product catalogue. In addition, the suggested air flow rate shall be an available option for the actual operation of the VRF system. In addition, an actual airflow measurement shall be performed on the installed VRF system to determine the actual airflow of the indoor units of the VRF system (Enteria et al., 2023). The airflow measurement used a device that measures the actual airflow of the installed indoor unit of the VRF system in the actual building. The actual air flow measurement shall be used in the thermal capacity.

1.3.4.5 Cooling Tests Real Performance Testing

The actual cooling capacity test referred to in this test report shall be performed with all indoor units operating under the air conditions specified in T1 of Table 2 of ISO 15042 (ISO, 2017b) and/or JIS B 8615-3 (JIS, 2015c).

Table 1.3.4-1. Comparison of system performance at cooling mode.

	Cooling mode	
	Cooling capacity, kW	Power consumption, kW
Catalogue value (rated)	22.40	6.61
Measured value (real)	21.41	6.65

The standard capacity test value based on ISO 15042 (ISO, 2017b) and/or JIS B 8615-3 (JIS, 2015c) shall be referred to when measuring the actual capacity. The results of the two tests shall be compared and made available as shown in sample Table 1.3.4-1. The measurement of the cooling capacity shall be derived from the air enthalpy method, the calculations of which are specified in ISO 15042 (ISO, 2017b) and/or JIS B 8615-3 (JIS, 2015c).

The appropriate conditioning of the air to stabilise the VRF system mentioned in ISO 15042 (ISO, 2017b) and/or JIS B 8615-3 (JIS, 2015c) shall be adopted to ensure the reliability of the data obtained. The data collection and analysis procedures shall follow the standards mentioned in ISO 15042 (ISO, 2017b) and/or JIS B 8615-3 (JIS, 2015c). In particular, the sample data evaluation and analysis shown in Figure 1.3.4-3 shall be considered. The adjustment period is to evaluate the thermal capacity setting of the chambers. The stabilisation period is to make sure that the thermal capacity reading is already the stable target reading.

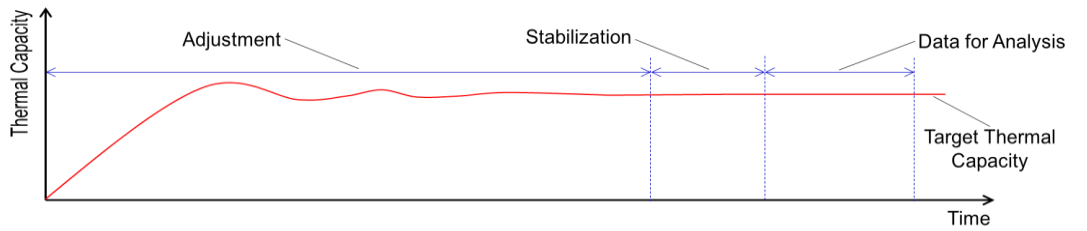

a)

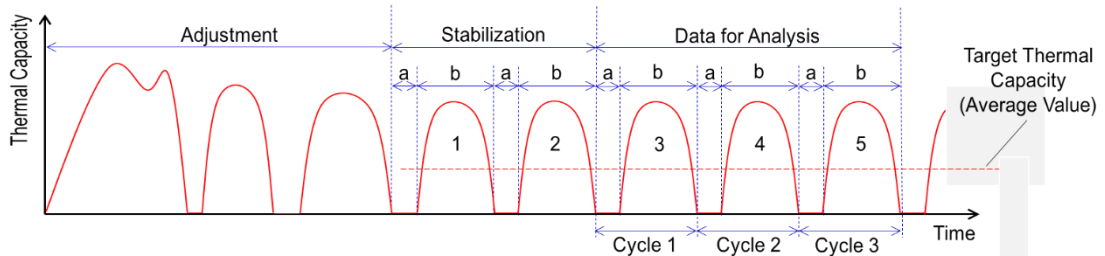

b)

Figure 1.3.4-3. Raw data observation and data for analysis: a) Steady compressor operation, and b) On and off compressor operation.

1.3.4.6 Partial Cooling Capacity Test

As part of the evaluation of a system, a partial cooling capacity test with a balanced thermal capacity ratio shall be conducted. During this test, the total indoor capacity of all units is reduced from the actual cooling capacity to the minimum possible cooling capacity of the VRF system, as shown in Figure 1.3.4-4. In addition, the air conditions specified in T1 of Table 2 in ISO 15042 (ISO, 2017b) and/or JIS B 8615-3 (JIS, 2015c) shall be used. In addition, the appropriate air conditioning conditions for the stabilisation of the VRF system mentioned in ISO 15042 (ISO, 2017b) and/or JIS B 8615-3 (JIS, 2015c) shall be followed. Data collection and analysis shall also follow the standards mentioned in ISO 15042 (ISO, 2017b) and/or JIS B 8615-3 (JIS, 2015c). The sample data evaluation and analysis shown in Figure 1.3.4-4 shall be considered, especially during cyclic operation (Figure 1.3.4-4b).

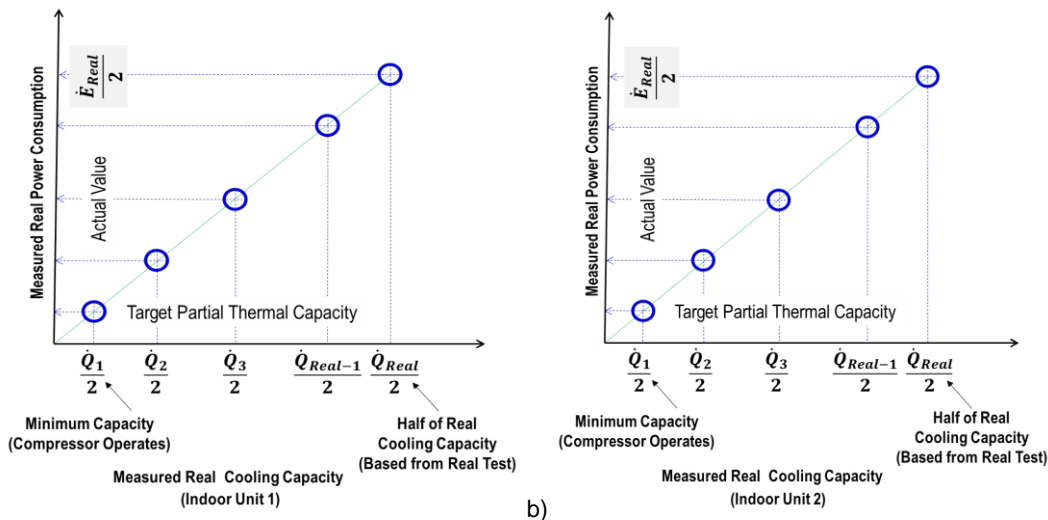

a)

b)

Figure 1.3.4-4. Power consumption at partial thermal capacity with balanced cooling capacity: a) indoor unit 1, b) indoor unit 2. Where E_{Real} = Measured power consumption, Q_t = Thermal capacity.

1.3.4.7 Heating Tests

1.3.4.7.1 Real Heating Capacity Test

The actual capacity test referred to in this test report shall be performed when all indoor units are operating at the outdoor and indoor air conditions specified in H1 of Table 7 of ISO 15042 (ISO, 2017b) and/or JIS B

8615-3 (JIS, 2015c). The catalogue capacity test based on ISO 15042 (ISO, 2017b) and/or JIS B 8615-3 (JIS, 2015c) shall be used as a reference when measuring the actual capacity test and the results shall be compared as shown in Table 1.3.4-2. Heating capacity measurements shall be based on the air enthalpy method with calculations taken from ISO 15042 (ISO, 2017b) and/or JIS B 8615-3 (JIS, 2015c).

Table 1.3.4-2. Comparison of system performance at heating mode.

	Heating mode	
	Heating capacity, kW	Power consumption, kW
Catalogue value (rated)	25.00	6.43
Measured value (real)	23.88	6.48

The conditioning of the air required to stabilise the VRF system as specified in ISO 15042 (ISO, 2017b) and/or JIS B 8615-3 (JIS, 2015c) shall be followed. Data collection and analysis shall follow the standards mentioned in ISO 15042 (ISO, 2017b) and/or JIS B 8615-3 (JIS, 2015c). The sample data evaluation and analysis shown in Figure 1.3.4.3 shall be consulted.

1.3.4.7.2 Partial Heating Capacity Test

The partial heating capacity test shall be performed with a balanced thermal capacity ratio. In this test, the total capacity of all indoor units is reduced from the capacity of the real heating capacity test to the minimum possible heating capacity at which the compressor of the VRF system can operate (Figure 1.3.4.5). The air conditions recommended in H1 of Table 7 ISO 15042 (ISO, 2017b) and/or JIS B 8615-3 (JIS, 2015c) shall be used. The air conditioning required to stabilise the VRF system according to ISO 15042 (ISO, 2017b) and/or JIS B 8615-3 (JIS, 2015c) shall be maintained. The data collection and analysis procedures shall adopt the standards mentioned in ISO 15042 (ISO, 2017b) and/or JIS B 8615-3 (JIS, 2015c). The sample data evaluation and analysis shown in Figure 1.3.4.5 shall be considered, especially during cyclic operation (Figure 1.3.4-5b).

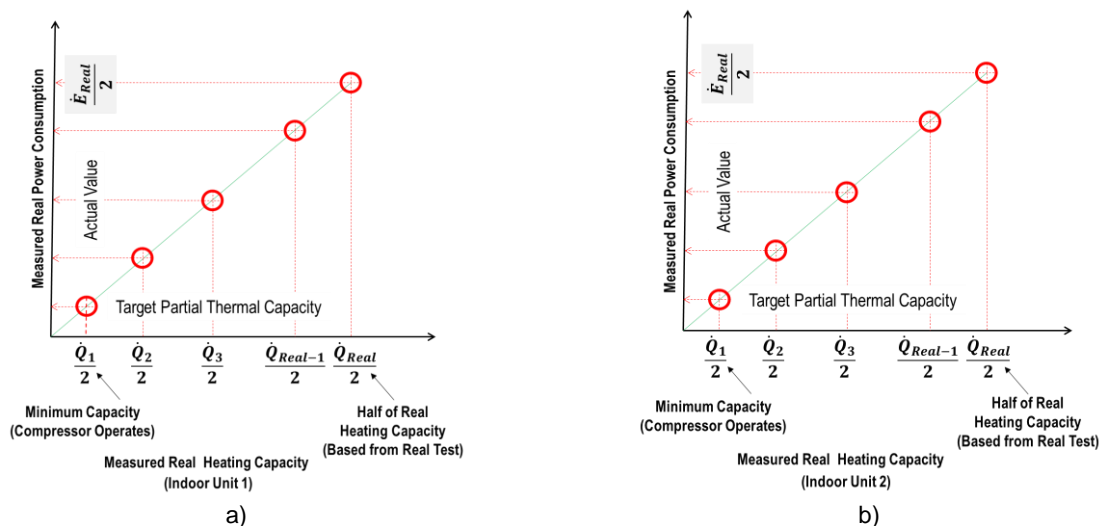

Figure 1.3.4-5. System power consumption at partial thermal capacity with balanced heating capacity: a) indoor unit 1, b) indoor unit 2. Where E_{Real} = Measured power consumption, \dot{Q}_i = Thermal capacity.

1.3.5 Load-based testing of hydronic heat pumps - load-based method (by BAM) and hardware-in-the-loop testing (by RWTH)

This section describes load-based test methodologies for hydronic heat pumps that are connected to a water-based heating system on the sink side. The source side can be air, brine, or water. The main section deals with a load-based test which aims to compare products under standardised yet representative test

conditions, whereas the final section gives a brief overview of hardware-in-the-loop testing as a holistic evaluating method.

The Federal Institute for Materials Research and Testing (BAM) assessed the current standards EN 14511 (BSI, 2018) and EN 14825 (BSI, 2022) within a research project ("Support for market surveillance – NAPE" (2015-2022)). To solve multiple issues arising from fixing the compressor speed and overriding the heat pump controller during the standard test, BAM developed the load-based test to measure units with active control under normal operation mode. This yields representative operation behaviour (on-off cycling under part-load), ensures that different appliances are tested under the same conditions (no individual increase of supply temperature/heating capacity under part-load conditions) and enables testing independent from the manufacturer. In 2019, BAM submitted a proposal in the review process of the EU ecodesign and energy labelling regulations for space heating appliances to revise the current EN-standards summarising the shortcomings of the current standard and the benefits of the load-based method (Simo et al., 2019). To validate the new method, repeatability and reproducibility were investigated in two round-robin tests (Wachau et al., 2023a). It was found that the inertia of the test stand impacts the operating behaviour under part-load conditions (Göbel et al., 2022). Therefore, the method was refined by introducing a simplified building model (emulator), which ensures the same response of different test stands (aligned inertia) and ensures the test stand responds like a real building (increased representativeness). The method is described in a test guideline published by BAM (BAM, 2023a) and an example of the building model is available in the form of a Python script on GitHub (BAM, 2023b). The proof-of-concept was successfully demonstrated in 2023 (Wachau et al., 2023b) and is followed by further round-robin tests. The following sections describe the emulator approach as of January 2024, including the two-mass building model.

1.3.5.1 Conceptual description of the testing methodology

As mentioned before, conventional heat pump test stands can vary significantly in their hardware and control design, resulting in very different response (physical and virtual inertia) under dynamic operation of the tested unit (e.g. on-off cycling or defrosting). Therefore, the emulator approach developed by BAM aligns inertia across different test stands by implementing a virtual building model in the test stand to ensure reproducible operating behaviour. This technology neutral approach allows existing hardware to be used (With minor hardware modifications/extensions any test standard is suitable).

The simplified building model (two-mass model, cf. Figure 1.3.5-1) computes the heat pump's water inlet/return temperature $\vartheta_{R,calc}$ (and the building temperature $\vartheta_{B,calc}$, where applicable) which is coming from the virtual building towards the heat pump. The test stand emulates these computed temperatures during the entire test duration. In particular, for each time step Δt_{step} , the model calculates the return temperature $\vartheta_{R,calc}$ and the building temperature $\vartheta_{B,calc}$ (output variables) based on the measured heat pump's water outlet temperature/supply temperature ϑ_s and the heating capacity \dot{Q}_{HP} (input variables) of the unit under test. Through the measured heating power, the model considers the supply temperature ϑ_s , return temperature $\vartheta_{R,emu}$, and mass flow rate \dot{m}_W . Like the supply temperature, the mass flow is controlled by the heat pump.

Based on a simple energy balance, the test stand dynamically adapts the so-called compensation load to match the calculated return temperature $\vartheta_{R,calc}$. The heat pump responds in accordance using its heating curve or its indoor temperature control or both as it tries to maintain the required supply temperature ϑ_s . Aligned with testing conditions in EN 14825 (BSI, 2022), the outdoor room shall maintain constant conditions over a temperature range associated with different climate zones for testing air-water heat pumps. Compared to the conventional testing procedure, the heat pump under the test is operated with its onboard control system (native control) active and not in a fixed-speed mode. The heat pump is, thus, permitted to switch into on/off operation of the compressor.

To ensure representativeness the building model is parametrised according to the test conditions defined in EN 14825 (BSI, 2022) considering the temperature application (e.g. low, medium or high) and the climate zones (cold, average, warm) (The concept can be applied to any temperature application, but representative time constants must be applied). In addition, the P_{design} of the heat pump is considered scaling the size

of the virtual building. The equations and a detailed description can be found in the test guideline published on the BAM website (BAM, 2023a).

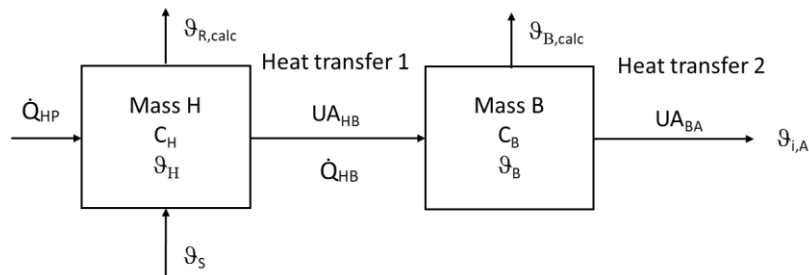

Figure 1.3.5-1. Schematic of the two-mass building model

1.3.5.2 How the tested system is operated

The emulator method allows for the use of conventional test stands with minor modifications to implement the building model. Depending on the type of unit, the source side contains a water loop or a climate chamber which ensures constant brine/water and outdoor conditions, respectively. The sink side comprises a water cycle, which is used to apply the required load. In accordance with EN 14825 (BSI, 2022), a test condition dependent setpoint for the supply temperature (water outlet temperature) and the heating capacity must be reached. For both measurements, the arithmetic mean value (over full cycles for on-off or defrost operation) is used.

The emulator method subjects the unit under test to the load dynamics of a representative building. In contrast to the current standard, the unit under test is operated with its on-board (native) control active. Prior to testing, only slight adjustments of the factory settings must be made on the installer level (single heating circuit, disable domestic hot water, etc.). In addition, the heating curve settings inside the controller are adjusted to match the set point for the supply temperature required by the specific test condition, as an installer would do. The controller modulates the compressor speed to match the load as it would do in the field. Hence, on-off operation is observed for loads below the modulation limit of the compressor. For loads below the bivalence point, two options can be applied: (a) the real or (b) a virtual electrical auxiliary heater is active, the power input of which is considered in the evaluation.

Figure 1.3.5-2 illustrates the difference between the fixed compressor speed test according to EN 14511 (BSI, 2018) and the load-based test on the same heat pump. The test conditions (E, A, B, C and D) defined in EN 14825 (BSI, 2022) are the same in both cases. However, to ensure steady-state operation of the compressor, the heating capacity must be increased below the modulation limit of the compressor. Thus, any deviation from the prescribed load-line is allowed in the standard test for conditions where on/off operation would occur and must be corrected afterwards. Consequently, different heat pumps are not tested under the same test conditions since the adjustment is individual for each heat pump. In contrast, the required load is always met during load-based tests within the permissible deviations, since on/off operation is enabled via active control. Hence, the operation behaviour is much more representative.

Finally, load-based tests can be performed independently from the manufacturer, whereas the standardised fixed frequency test in general, requires intervention from the manufacturer to set different parameters in the test mode.

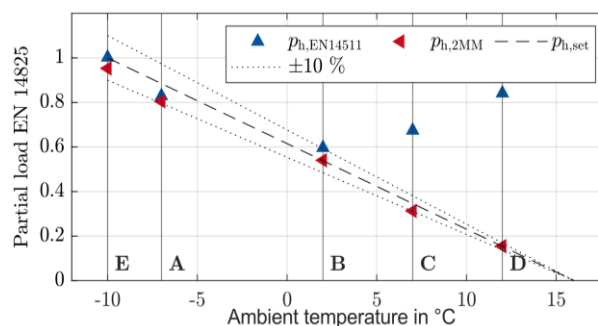

Figure 1.3.5-2. Partial loads measured on the same heat pump according to EN 14511 (BSI, 2018) and the emulator method (2MM) at different test conditions defined in EN 14825 (BSI, 2022). The load curve

(setpoint) and permissible deviations according to EN 14825 (BSI, 2022) are depicted by dashed and dotted lines, respectively

1.3.5.3 Illustrative test results

Figure 1.3.5-3 compares measurements at part load condition C according to EN 14511 (BSI, 2018) and the emulator method. During the standard test, the supply and return temperatures are quasi-constant since the compressor speed is fixed, whereas on-off operation is observed for the load-based test, which is reflected in the periodic increase in supply and return temperatures. The dynamic operation in the latter case is due to the native controller trying to match the load below the modulation limit of the compressor. As previously emphasised, the mean value of the supply temperature is much higher for the standard test, which requires steady-state operation of the compressor, resulting in a too high heating capacity (supply temperature) compared to the test condition defined in EN 14825 (BSI, 2022).

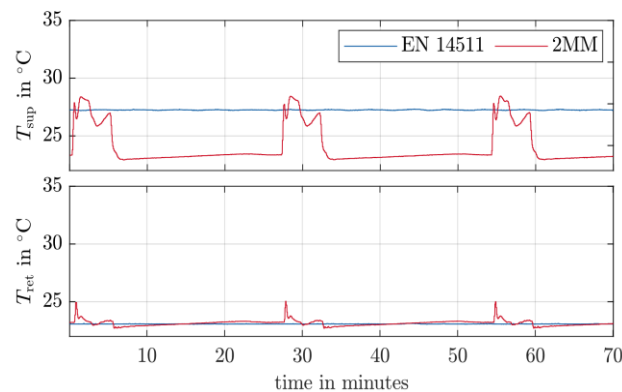

Figure 1.3.5-3. Measured supply and return temperatures according to EN 14511 (BSI, 2018) and the emulator method (2MM) on the same heat pump.

1.3.5.4 Selection of set of test conditions

The load-based test can be applied to any test condition if the source side conditions are constant. So far, test conditions according to EN 14825 (BSI, 2022) have been used since the load-based test was developed to replace the fixed frequency test defined in EN 14511 (BSI, 2018).

1.3.5.5 Assessment of repeatability, reproducibility, and representativeness of the test results

The repeatability and reproducibility of the load-based test has been assessed in two round robin tests (RRT) with an A/W and a W/W heat pump from 2020-2021 (Wachau et al., 2023a). Similar reproducibility was found compared to the current standard. However, very different inertia of the test rigs in the RRT leads to non-uniform operating behaviour. Especially, quick responding test rigs with low inertia failed to reach the setpoint for the heating capacity. In the following, the two-mass building model was introduced to align the test stand response independently from its physical inertia and ensure the same operating behaviour. The concept has been proven on three test stands with three different heat pumps (Wachau et al., 2023b). Starting from September 2023, a new round-robin test is launched by BAM and RWTH to investigate the reproducibility of the emulator (building model) based approach and to refine the test guideline based on the observations.

1.3.5.6 Definition of seasonal performance indices

The calculation of the seasonal coefficient of performance (SCOP) is defined in EN 14825 (BSI, 2022) and can be applied to load-based measurements. Slight adjustments in the calculation procedure are required since the electrical power consumption for the back-up heater is directly recorded during the load-based measurement and included in the measured COP opposed to the standard correcting a lack in heating

capacity during the SCOP calculation. The electrical power consumption of the back-up heater can either be measured directly, in case of a real back-up heater, or calculated virtually.

1.3.5.7 Outlook: Holistic Testing of Building Energy Systems

The load-based-testing method described in the following is based on the Hardware-in-the-Loop (HiL) approach that couples hardware and software in real-time. At RWTH Aachen University, we developed a method for testing the holistic building energy system, including further components like the hydraulic transfer system, PV-systems or thermal energy storages (TES) (Mehrfeld, 2022). The device under test can be the heat source (e.g. heat pump), the TES, and the control algorithms. Therefore, the scope of this method goes beyond the load-based approach described above, which aims to compare product performance under standardised conditions.

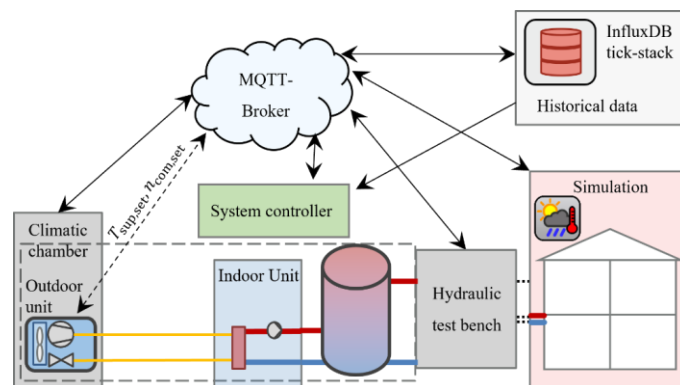

Figure 1.3.5-4. Schematic overview of holistic BES testing.

The developed method creates an experimental-based annual KPI (e.g. SCOP) by performing the following steps:

1. The BES is modelled, including all components.
2. A sensitivity analysis and clustering algorithm delivers typical days for a specific location.
3. The typical days are experimentally investigated with the HiL approach
4. Annual KPIs are calculated from the daily KPIs.

Figure 1.3.5-4 shows the schematic overview of the holistic test approach. A modern model predictive controller (MPC) is investigated in the example. We use a fully controllable heat pump test bench for a deep control interface. To couple the climatic chamber, the hydraulic test bench, the system controller, and the heat pump with the building performance simulation, we transfer data via the MQTT protocol. The building performance simulation is a multi-zone Modelica model realised with the BESMod Modelica library (Wüllhorst et al., 2022).

Figure 1.3.5-5 shows exemplary the test of one typical day for the BES controlled by an MPC. The figure shows the room temperature (red line) and comfort bounds (black line) at the top. The middle figure illustrates the heat pump's relative compressor speed while the bottom figure gives the set supply (black dashed line) and the measured supply temperature (red line). The experiments show the potential for holistic BES testing and support the introduction of complex control algorithms into practice. Further details can be found in (Göbel et al., 2023).

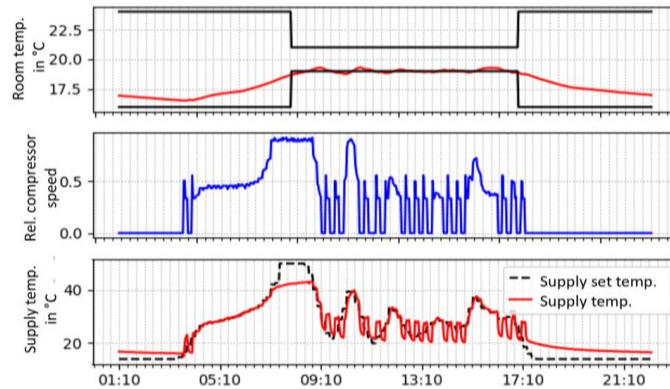

Figure 1.3.5-5. Hardware-in-the-Loop test for a building energy system controlled by an MPC.

1.4 Perspectives of load-based test standards and R&D plans in Annex 88

1.4.1 Perspective of load-based tests and considerations on methods of utilisation of the results

When the building-level policies started in the late 1970s, they dealt only with the thermal performance of the building envelope. After year 2000, many national or regional building-level policies started covering equipment's energy performance, including heat pump systems. Because of the fundamental nature of heat transfer, it is conceptually incorrect to separate the performance of heating and cooling supply technologies from the building envelope and vice versa. However, in practice, the different approaches adopted in product- and building-level policies have resulted in fundamental differentiations, if not incompatibilities, between the two levels of analysis. Insufficient communication between tests conducted for product- and building-level policies results in inconsistent testing conditions and methodologies, making results obtained when testing product efficiency not applicable for building evaluations, and eventually increasing the required testing time and cost to the industry.

The review of new testing methodologies and rating standards conducted in Annex 88 is also intended to recognise potential convergences between the information extracted during product-level performance ratings and building-level energy calculations, simulations, and equipment sizing.

As mentioned in Section 1.1, product-level policies are intended to provide values representing products' energy efficiency and are used to compare different products of the same kind. Product-level evaluation of energy efficiency does not aim to characterise the complete spectrum of possible load scenarios and building characteristics, and simplifying assumptions must be made on the relationship between outdoor temperature and heat needs, for instance.

On the other hand, building-level policies and standards rely on values representing products' energy efficiency, which are used to evaluate overall energy performance (i.e., total energy consumption) of the buildings. The energy calculation results are frequently used to compare energy reductions with different products and technologies. Additionally, designers' decisions related to equipment sizing (e.g., heat pumps) are one of the main targets for evaluating the building's energy performance. To increase the resolution and reliability of building-level evaluations, energy efficiency of equipment under low partial load conditions has become critical, mainly because the actual partial load ratio for the equipment may substantially deviate from the assumptions made in the product-level standards, and it is not uncommon for designers to oversize building equipment to avoid any shortage in heating/cooling capacity. Therefore, building-level policies increasingly require evaluations with higher resolution and complexity, which imply a continuous methodology improvement in the search for higher resolution of the energy characterisation. Examples of policies are added in the lower part of Table 1.4.1-1, which summarises the essential features of product- and building-rating policies.

Testing methodologies for product-level policies provide the fundamental measurements and material for:

- the development of effective Minimum Energy Performance Standards for meeting the conflicting challenges of increasing demand for heating and cooling with the necessity of energy saving,
- defining the basis for performance rating of units available in the market,
- capturing realistic operation characteristics that may stimulate technology developments, evidence-based policies, and guide consumers to beneficial choices.

The development of testing methodologies for assessing the performance of heat pumps and air conditioners when operated under the same control as in buildings presents both challenges and opportunities.

These arise from the dynamic characterisation of system operation and the performance relationships to building and load features, similar to those observed in field installations. The reviewed testing methodologies are intended to: develop new product level standards, support building-level policies by providing data for energy modelling and simulation purposes, provide evidence for efficient equipment sizing and selection, as well as for the development of more efficient design and control.

Table 1.4.1-1. Comparison of product- and building-level standards.

		Product-level standards:	Building-level standards:
(1) Scope		Provide comparable values representing products' energy efficiency to compare different products of the same type. Allow for determination of high and low performing equipment of the same equipment type.	Evaluate overall energy performance of the building and evaluate the suitability of different kinds of systems within the building. <u>*default characteristics for energy efficiency under partial load conditions are presently being utilised along with the rated energy efficiency of the HP.</u>
(2) Seasonal or annual average efficiencies		Necessary for regulating the energy efficiency level of each product category. <u>The assumption of the relationship between heat needs imposed on HP and the maximum capacity of the HP: fixed ratios are applied, such as 1.0 for cooling in JIS C 9612.</u> <u>Assumption on the relationship between the heat needs and outdoor temperature: a linear relationship is assumed.</u>	Not necessary. Instead, whole building energy performance is regulated with calculated energy use by buildings. The relationship between the thermal load imposed on HP and the maximum capacity of the HP is influenced by building/interior space usage and designers' decision on sizing the HP. The thermal load is also influenced by solar radiation and outdoor humidity.
Examples of relevant policies	EU	The Ecodesign Directive prescribes minimum requirements for SEER and SCOP, and only products compliant with the requirements can be sold. The definitions of the SEER and SCOP are prescribed in EN14825 based on EERs and COPs at load ratios of 100%, 75%, 50%, and 25%.	National building energy standards based on EPBD. European standards on the methods for energy calculation are developed as EPB standards. EN 15316-4-2 is one of them, which is for space heating heat pump systems.
	US	AHRI standards prescribe SEER and HSPF (Heating Seasonal Performance Factor) based on test results at full, intermediate, and low compressor stages. DOE implements minimum SEER and HSPF with the authorization of the National Appliance Energy Conservation Act of 1987.	For non-residential buildings, ASHRAE Standard 90.1 prescribes the whole building performance approach using a simulation tool, such as EnergyPlus. The building energy codes are implemented based on the Energy Conservation and Production Act of 1976.
	JP	Top-runner programs for HP systems are implemented in the Energy Conservation Law and its ordinances. Relevant JIS standards with testing methods for full and intermediate capacities define the Annual Performance Factor (APF).	In the Building Energy Conservation Law and its ordinances, the calculation methods for primary energy use of buildings are prescribed with standard primary energy uses. In the methods, rated energy efficiencies and default curves for the relationship between partial load ratio and input power for HPs are used for energy use calculations.

In principle, load based tests rely on the same equipment and instrumentation required by current standards, while revisiting the software elements of the testing facility (though some specialised test apparatus may be required depending on the method undertaken). It can be arguably stated that load-based tests might require more time for test convergence than current standards, but this may be related to the necessary learning curve needed for new procedures and could be quantitatively assessed during subsequent efforts of subtask B1 on testing methodologies. The possibility of testing heat pumps under the same control as operating in field installations provides opportunities for automating tests and provides additional value in terms of representativeness of field operation and transparency.

Finally, a strategic choice of test points for product standards has the potential to narrow the gap between product- and building-level policies, and eventually limit overall testing time and cost when considering overall interests of manufacturers, designers, planners, and installers. One challenge to this process is that the interest of planning and product comparison is to have a relatively simple (and less expensive) method to reasonably demonstrate a standardised metric, mostly for product comparison or differentiation; but this lower cost approach does not provide the complete performance maps that are needed for accurate simulation and design. More work can be done to bridge that gap, which may include: streamlining test procedures and the choice of test conditions to provide a better compromise between these differing needs; the use of load based testing to validate a subset of fixed-speed data (that may be available at a wide range of operating conditions); the creation of better models that allow interpolation of tested, load-based operating conditions to other conditions that facilitate both types of metrics; or other innovations, which also may vary by different heat pump technologies.

1.4.2 Perspective within Subtask B1 of Annex 88 Perspective of load-based tests and considerations on methods of utilization of the results

Efforts to advance load-based and innovative testing methodologies should address the challenges and technical solutions necessary for developing experimental methods that go beyond product performance characterisation. These methods may also serve the purposes of design and control development, modelling, energy calculations, and efficient energy management techniques, particularly in the context of heating and cooling technologies and their complex interaction with the built environment and grid dynamics. During the working phase of Annex 88, the reviewed proposals for the testing methodologies of Category B standards will be compared in detail to exchange expertise and provide evidence of the required testing time and cost, as well as repeatability, reproducibility, and representativeness of the results. Additionally, the comparison of procedures and results with the corresponding Category A standards shall provide quantitative insights for clarifying the performance gap with heat pumps and air conditioners when operated under the same control as operated in buildings.

Consequently, pathways toward adoption including such opportunities as regulator adoption, program adoption (e.g., as an eligibility for incentives or subsidy programs), and building code reference, should be discussed.

The activity of Annex 88 is also intended to increase result comparability across jurisdictions and harmonise standard performance rating procedures toward convergence to a common proposal: for instance, the final results of Annex 88 will support the proposal for load-based tests currently under review within the ISO TC86 for the drafting of a new standard.

1.5 References for testing methods

- AHRI. Standard AHRI 1230 (2010). Performance Rating of Variable Refrigerant Flow (VRF) Multi-Split Air-Conditioning and Heat Pump Equipment.
- AHRI. Standard AHRI 210/240 (2023). Performance Rating of Unitary Air-conditioning & Air-source Heat Pump Equipment.
- ANSI/ASHRAE. Standard ANSI/ASHRAE 37-2009 (2019). Methods of Testing for Rating Electrically Driven Unitary Air-Conditioning and Heat-Pump Equipment.
- BAM -Bundesanstalt für Materialforschung und -prüfung (2023a). Test guideline for a load-based performance testing (heat pumps) 12/2023. Available: <https://netzwerke.bam.de/Netzwerke/Content/DE/Downloads/Evpg/Heizen-Kuehlen-Lueften/bam%20test%20guideline%20-%20load-based%20testing%20of%20heat%20pumps%202023.pdf.html>.
- BAM -Bundesanstalt für Materialforschung und -prüfung (2023b). Python script of two-mass building model for load-based-testing of hydronic heat pumps. Available: <https://github.com/BAMresearch/bam-load-based-testing>
- Ban, T.; Ohno, K.; Yamaguchi, S.; Saito, K.; Yamaguchi, H. (2016). Evaluation Method of Compression type Heat Pump for Actual Driving Performance - Construction of evaluation device and proposition of unsteady evaluation method. Proceedings of 2016 JSRAE Annual Conference, Kobe, Japan. (in Japanese).
- Ban, T.; Nakano, D.; Ohno, K.; Yamaguchi, S.; Saito, K.; Yamaguchi, H. (2017). Testing facility for unsteady performance of air conditioning System. Proceedings of 12th IEA Heat Pump Conference 2017, Rotterdam.
- BSI – British Standard Institution (2018). Standard BS EN 14511-Part 3: Air Conditioners, Liquid Chilling Packages and Heat Pumps for Space Heating and Cooling and Process Chillers, with Electrically Driven Compressors. Test methods.
- BSI – British Standard Institution (2022). BS EN 14825:2022: Air conditioners, liquid chilling packages and heat pumps, with electrically driven compressors, for space heating and cooling, commercial and process cooling. Testing and rating at part load conditions and calculation of seasonal performance.
- CSA. CSA C656 (2014). Performance standard for split-system and single-package air conditioners and heat pumps.
- CSA. CSA SPE-07:23 (2023a). Load-based and climate-specific testing and rating procedures for heat pumps and air conditioners. Available: <https://www.csagroup.org/store/product/CSA%20SPE-07%3A23/> (free of charge at <http://community.csagroup.org/>).
- CSA. EXP07:19 Plain Language Guide (2023b). Available in: <https://www.csagroup.org/store/product/CSA%20SPE-07%3A23/>.
- Dhillon, P; Wang, X; Horton, W.T.; Braun, J. (2022). Repeatability and Reproducibility Assessment of Residential Heat Pump Performance Evaluation Methodologies based on CSA EXP07 and AHRI 210/240. Herrick Refrigeration and Air Conditioning 2022 Conference Proceedings. West Lafayette, IN: Purdue University; 2022. <http://docs.lib.purdue.edu/iracc/2477/>.
- Dondini, D.; Giannetti, N.; Mizuno, A.; Miyaoka, Y.; Saito, K. (2024). Reproducibility assessment of an emulator-type load-based testing methodology, International Journal of Refrigeration, Volume 159, 2024, Pages 39-49.
- Enteria, N.; Yamaguchi, H.; Miyata, M.; Sawachi, T.(2015). Performance Evaluation of the Variable Refrigerant Flow (VRF) Air-Conditioning System Subjected to Partial and Unbalanced Thermal Loading. *Journal of Thermal Science and Technology*, Vol. 11.
- Enteria, N.; Yamaguchi, H.; Miyata, M.; Sawachi, T.(2016). Performance Evaluation of the Variable Refrigerant Flow (VRF) Air-Conditioning System Subjected to Partial Loadings at Different Outdoor Air Temperature. *Journal of Thermal Science and Technology*, Vol. 11.

- Enteria, N.; Yamaguchi, H.; Miyata, M.; Sawachi, T.; Kuwasawa, Y. (2017). Performance Evaluation of the Variable Refrigerant Flow (VRF) Air-Conditioning System during the Heating-Defrosting Cyclic Operation. *Journal of Thermal Science and Technology*, Vol. 12.
- Enteria, N.; Yamaguchi, H.; Miyata, M.; Sawachi, T.; Kuwasawa, Y. (2023) An Air Enthalpy Method for Measuring the Thermal Capacity of an Installed Variable Refrigerant Flow System, Chapter 1. In: Enteria N., Sawachi T., Saito K. (Editors) Variable Refrigerant Flow System – Advances and Applications of VRF, Springer, Singapore.
- Giannetti N.; Ariyadi, H.; Miyaoka, Y.; Jeong, J.; Saito, K.(2022a). Development of an Emulator-Based Assessment Method for Representative Evaluation of the Dynamic Performance of Air Conditioners. International Refrigeration and Air Conditioning Conference. Paper 2448.
- Giannetti, N.; Matsui, S.; Mori, R.; Jeong, J.; Ariyadi, H.; Miyaoka, Y; Togashi, E.; Saito, K. (2022b). Emulator-type load-based tests for dynamic performance characterization of air conditioners. *Energy and Buildings* 273, 112411.
- Giannetti, N.; Sholahudin; Mizuno, A.; Miyaoka, Y.; Sei, Y.; Enoki, K.; Saito, K. (2024). Feed-forward compensation for emulator-type testing facilities, *International Journal of Refrigeration*, Volume 167, 2024, Pages 257-268, ISSN 0140-7007, <https://doi.org/10.1016/j.ijrefrig.2024.07.023>.
- Göbel, S.; Zottl, A.; Noack, R.; Mock, D.; Wachau, A.; Vering, C.; Müller, D. (2022). How to calibrate heat pump test stands for load-based testing – towards technology-neutral prescriptions. Proceedings of the 14th International Conference on Applied Energy (ICAE2022), Bochum, Germany.
- Göbel, S.; Stoffel, P.; Will, F.; Müller, D. (2023). Maximizing operational efficiency of heat pumps with Model Predictive Control: An experimental case study for residential application, Proceedings of the 14th IEA Heat Pump Conference, Chicago, May 2023.
- Harley, B. Butler, D., Dymond, C. Hamer, G., McWilliams, J. and Yuill, D. (2023). Field tests of variable speed heat pumps to compare load-based and fixed-speed test and rating methods. Proceedings, International Energy Agency, 14th IEA Heat Pump Conference, Chicago, IL. www.hpc2023.org/wp-content/uploads/gravity_forms/3-7075ba8a16c5f78b321724d090fb2a34/2023/05/0438_HPC2023_Full_Paper_Yuill_v02.pdf .
- Harley, B.; Dymond, C.; Yuill, D. Hamer, G; McWilliams, J.; Chen, Y. (2024). Field and Lab Testing of Residential Heat Pumps to Assess Representativeness of Fixed-speed and Load-based Test Methods, Proceedings of Purdue University, 2024 Herrick Refrigeration and Air Conditioning Conference.
- ISO - International Organization for Standardization (2017a). Standard ISO 5151:2017: Non-Ducted Air Conditioners and Heat Pumps Testing and Rating for Performance. International Organization for Standardization.
- ISO - International Organization for Standardization (2017b). Standard ISO 15042:2017: Multi Split-System Air Conditioners and Air-To-Air Heat Pumps – Testing and Rating for Performance. International Organization for Standardization.
- ISO - International Organization for Standardization (2020). ISO 3966:2020. Measurement of Fluid Flow in Closed Conduits Velocity Area Method Using Pitot Static Tubes. International Organization for Standardization.
- ISO - International Organization for Standardization (2022). ISO 5167-1:2022: Measurement of Fluid Flow by Means of Pressure Differential Devices Inserted in Circular Cross-Section Conduits Running Full. Part 1: General Principles and Requirements. International Organization for Standardization.
- JIS - Japanese Industrial Standards (2013). Standard JIS C 9612:2013: Room air conditioner.
- JIS - Japanese Industrial Standards (2015a). Standard JIS B 8616:2015: Packaged air conditioner.
- JIS - Japanese Industrial Standards. Standard JIS B 8627:2015 (2015b). Gas heat pump air conditioner.
- JIS - Japanese Industrial Standards (2015c). Standard JIS B 8615-Part 3: Multi Split-System Air Conditioners and Air-To-Air Heat Pumps – Testing and Rating for Performance. Japan Industrial Standards.

- Miyaoka, Y.; Mori, R.; Giannetti, N.; Jeong, J.; Togashi, E.; Saito, K.(2023). Emulator-type Load-based Testing Methodology for Dynamic Performance Characterization of Air Conditioners. Transactions of the Japan Society of Refrigerating and Air Conditioning Engineers, e.22-17 _OA, February 2023. (in Japanese)
- Mehrfeld, P. 2022. Evaluation of heat pump systems under dynamic operating conditions; PhD thesis, RWTH Aachen University, 2022. doi: 10.18154/RWTH-2022-06640.
- NEEP. NEEP (2023a). Final Report – Public Version, Residential Heat Pump Efficiency Rating Representativeness Project Phase 1.
- NEEP. NEEP (2023b). Working title: Final Report, Residential Heat Pump Efficiency Rating Representativeness Project Phase 2, awaiting publication by NEEP.
- Simo, A.; Palkowski, C.; Wachau, A. (2019). *Proposal for the revision of the harmonised test standard EN 14825:2016*. Available: https://netzwerke.bam.de/Netzwerke/Content/DE/Downloads/Evpg/Heizen-Kuehlen-Lueften/proposal_revision_en14825_final.pdf.html
- Togashi, E.; Tanabe, S. (2009). (Methodology for developing heat-load calculating class library with Immutable interface), Technical papers of annual meeting, The Society of Heating, Air-Conditioning Sanitary Engineers of Japan, 3 2009 1995-1998. (In Japanese).
- Wachau, A.; Mock, D.; Minelli, P.(2023a). *BAM technical report on load-based testing of hydronic heat pumps - compensation method*. Available : <https://netzwerke.bam.de/Netzwerke/Content/DE/Downloads/Evpg/Heizen-Kuehlen-Lueften/bam%20report%20load%20based%20testing%20heat%20pumps%20-%20compensation%20method%202023.html>
- Wachau, A.; Göbel, S.; Vering, C.; Mock, D.; Müller, D. (2023b). *Increasing energy efficiency and acceptance of heat pumps through realistic test procedures – Proof of concept on compensation method*. Available: https://www.dbu.de/OPAC/ab/DBU-Abschlussbericht-AZ-38677_01-Hauptbericht.pdf
- Wüllhorst, F.; Maier, L.; Jansen, D.; Kühn, L.; Hering, D.; Müller, D. (2022). BESMod - A Modelica Library providing Building Energy System Modules, American Modelica Conference 2022, Dallas, Oct. 2022.

2. State of the art for field monitoring methods and database for actual energy efficiency of heat pump systems

2.1 Background

As a promising technology for cooling and heating, heat pump has been applied in various commercial buildings, residential buildings and industrial buildings worldwide. According to its configuration, a heat pump can be packaged or split, ducted or ductless, portable or stationary. Typical heat pump types include mini-split system, variable refrigerant flow (VRF) system or multi-split system, packaged window unit, central ducted split system, packaged roof top unit, etc. (IEA, 2019) The global demand forecast for commercial and residential air conditioners in 2022 is estimated to have increased by 107% compared to the previous year, with approximately 17.87 million units for commercial use and 99.9 million units for residential use (JRAIA, 2023). In China, annual production of RACs reaches 218 million units in 2022. Moreover, VRF system has long held the market's largest share for central air conditioning (Central Air Conditioning Market, 2020). The Chinese market's enormous sales volume has aided in the growth of VRFs in the European and American markets.

In the background of the vast market scale, actual performance and energy efficiency of the heat pump system has raised wide attention in recent years. Although heat pump systems exhibit high performance efficiency with various control strategy optimizations in the laboratory, their actual field performance could be much different. Actual operation characteristics are affected by various factors, such as indoor and outdoor environmental parameters, pipe length and installation condition, thermal performance of enclosure structure, occupants' behaviour and so on, which could differ from those in the laboratory. In actual operation, such as short-circuiting in the outdoor unit during cooling, defrost operation during heating, and low-load operation due to excess equipment capacity for claims, avoidance lead to a deviation of energy performance from the values in the catalogue. According to the field test by Won et al. (Won et al. 2009), the actual energy efficiency of the VRF system in cooling season was only 1.74 kWh/kWh, which is remarkably lower than its nominal cooling energy efficiency of 2.64 kWh/kWh. According to the investigation by Matsui et al. (Matsui et al., 2016), the average operating ratio (actual output/nominal output) of VRF system in Japan is approximately 25%. The normalisation of oversized capacity leads to inefficient operation.

Accurate measurement of the cooling and heating capacity becomes the focal point of field performance measurement since the energy efficiency index (EER) for the cooling mode and (COP) for the heating mode could be calculated, respectively, from the energy consumption and capacity. The energy efficiency index such as EER (Energy Efficiency Ratio), SEER (Seasonal Energy Efficiency Ratio), and COP (Coefficient of Performance) are all calculated as the ratio of capacity to energy consumption, making accurate measurement of cooling and heating capacities a crucial focus in on-site evaluations.

Among the different types of heat pump, cooling/heating performance of water-medium ones can be easily measured by measuring the water flow rate and its temperature difference. However, for air-to-air systems, on-field capacity-related performance of the system is hard to be determined, though electricity consumption can be measured (Matsui&Kametani, 2020). As a result, the challenge of performance measurement to air-to-air system impedes the development of energy management, energy-saving operation, system retrofitting.

Thus, this chapter reviews the state of art for field monitoring methods of heat pump systems (mainly focus on air-to-air system) and introduces some measurement result and database for actual performance of heat pump.

2.2 Current field monitoring methods

The cooling or heating capacity can be obtained for water-cooled heat pump systems by measuring the water temperature difference and water circuit flow rate. However, this is not the case for air-to-air heat pump.

2.2.1 Air-air heat pump systems

The basic principle of performance measurement of air-to-air heat pump is presented in Figure 2.2.1-1 (Enteria et al., 2023). In order to obtain the cooling or heating capacity of the air-to-air system, researchers mainly focus on two methodologies according to the measured medium (air or refrigerant), namely the air-specific enthalpy difference (AE) method and refrigerant specific enthalpy difference (RE) method. According to different acquisition methods of air volume and air enthalpy difference, the AE method is further divided into indoor side AE method and outdoor side AE method. The former comprises indoor air hood method and indoor air sampling method, the latter is composed of the outdoor air hood method, static multi-point sampling method, static outlet air sampling method and dynamic outlet air sampling method. Based on a different of refrigerant mass flow measurement principle, the RE method is divided into the refrigerant flowmeter method, compressor performance curve method, compressor volume efficiency method, numerical calculation method and compressor energy conservation method.

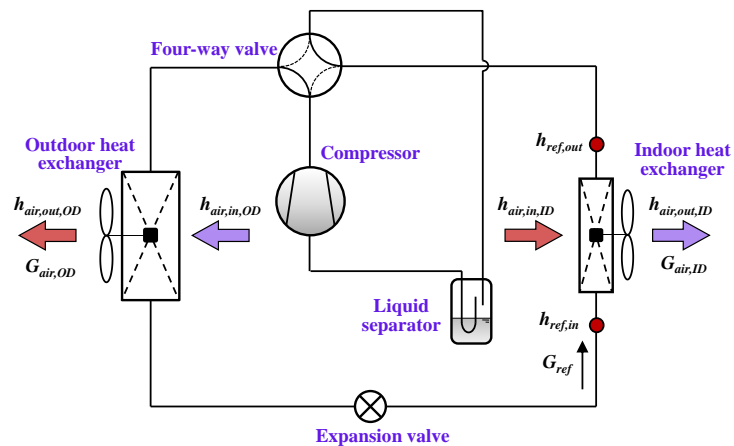

$$\begin{array}{l}
 \dot{Q}_{cc} = \dot{m}_{air,ID} \cdot (h_{air,in,ID} - h_{air,out,ID}) \\
 \dot{Q}_{hc} = \dot{m}_{air,ID} \cdot (h_{air,out,ID} - h_{air,in,ID})
 \end{array}
 \quad \Bigg| \quad
 \begin{array}{l}
 = \dot{m}_{air,OD} \cdot (h_{air,out,OD} - h_{air,in,OD}) - P_{com} \\
 = \dot{m}_{air,OD} \cdot (h_{air,in,OD} - h_{air,out,OD}) + P_{com}
 \end{array}
 \quad \Bigg| \quad
 \begin{array}{l}
 = \dot{m}_{ref} \cdot (h_{ref,out} - h_{ref,in}) \\
 = \dot{m}_{ref} \cdot (h_{ref,in} - h_{ref,out})
 \end{array}$$

Indoor air side
Outdoor air side
Refrigerant side

Figure 2.2.1-1. Basic principle of field performance measurement to air-to-air heat pump

2.2.1.1 Indoor side air enthalpy difference method

The indoor side air enthalpy difference method mainly includes the indoor unit external air hood and the indoor unit outlet air sampling method. The external method is based on the traditional heat transfer measurements on the air side, mainly air flow rate, inlet and outlet temperature, and corresponding air properties, such as density and specific heat capacity. The air flow rate can be measured directly by anemometer or calculated according to a fan curve validated by experiments, such as a function among air flow rate, fan rotation speed and power consumption.

2.2.1.1.1 Air hood method

The air hood introduces all the air outlets of the indoor unit into the air duct, and the fan adjusts its speed at the end of the air duct to balance the pressure loss caused by the test devices at the same time (Jactard&Li, 2011). The anemometer and the temperature/humidity sensors were used to obtain the air volume and the parameters before and after the heat exchanger. In addition, at least four groups of temperature and humidity sensors should be installed in the inlet and outlet of the indoor unit evenly distributed. To obtain accurate air density and specific heat capacity, a group of temperature and humidity sensors shall be arranged near the pressure sensor. Although use of multiple groups of temperature and humidity reduces the error caused by thermal non-uniformity, it is not convenient because it disturbs the regular operation for both users and units.

2.2.1.1.2 Air sampling method

To simplify the test difficulties, the air sampling method was proposed. The indoor unit's inlet and outlet distribution is determined through multi-point measurement in advance; therefore, the air hood could be left out in the field test. The inlet and outlet areas are normally divided into several small regions, and the air temperature, humidity, and velocity are measured, respectively.

Figure 2.2.1-2 shows the test principle of an indoor unit of a multi-connected air conditioner of a four-side air outlet ceiling unit (Ichikawa et al., 2008). The scalar and vector anemometer measured three-dimensional airflow velocities in and from the unit, creating an accurate airflow velocity distribution curve. The air inlet and outlet volumes are calculated by integrating distributed sensors and each measuring point's correction factor. The temperature and humidity sensors are arranged in each measuring point area. Therefore, the cooling capacity was finally obtained.

Figure 2.2.1-3 shows the thermal and vector velocity distribution in the indoor unit, where the airflow at the outlet is also complex, similar to the outdoor unit. Ensuring this method's accuracy is hard, especially in the cooling condition. Moreover, using the arithmetical average should be avoided since the supply air exhibits evident non-uniformity.

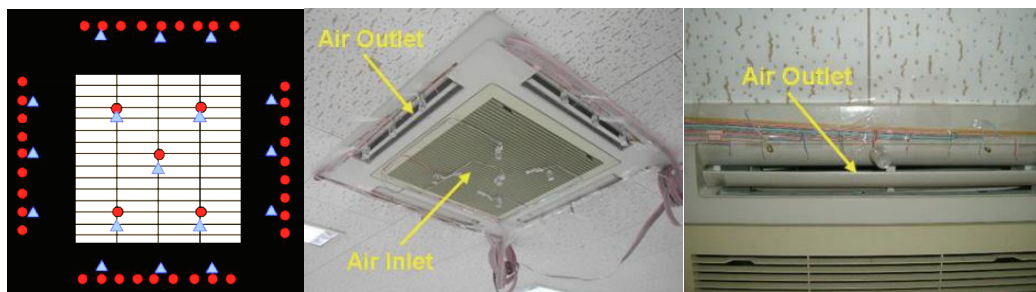

(a) Measuring point (b) Air inlet and outlet (c) Sensors of air outlet
Figure 2.2.1-2. Air sampling method

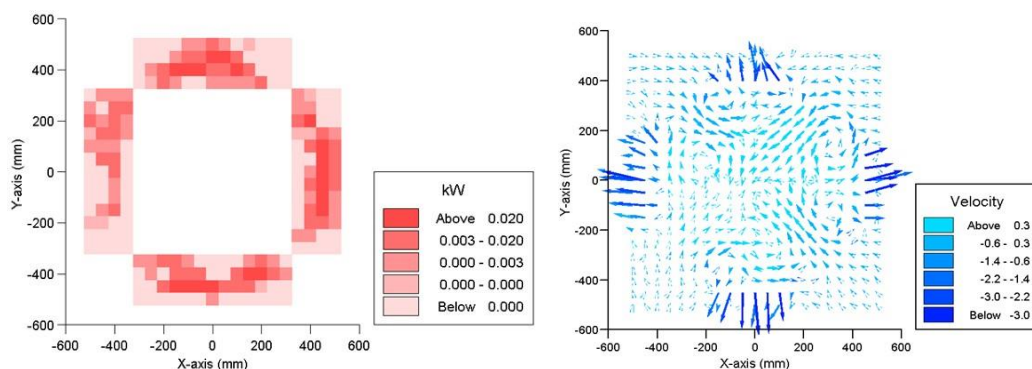

Figure 2.2.1-3. Thermal and vector velocity distribution on the indoor unit

2.2.1.2 Outdoor side air enthalpy difference method

Although the indoor air enthalpy difference method has the advantage of being free from the interference of outdoor meteorological conditions, it is difficult to achieve high-precision long-term measurement due to its interference from the users.

2.2.1.2.1 Static multi-point air sampling method

The cooling/heating capacity was calculated by multiplying the enthalpy difference and the air mass flow rate in the static multi-point air sampling method. The specific enthalpy is calculated by arranging several groups of temperature and humidity sensors at the inlet and outlet of the outdoor unit. Similarly, the air volume was determined by measuring air speed in multiple positions of the outdoor unit. Probing temperature sensors show better accuracy since they penetrate the heat exchanger and the synchronisation (Nobe et al., 2011). Each probing sensor is equipped with two T-type thermocouples, one of which is put on the exterior of heat exchange fins, and the other penetrates through fins into exhaust air chambers so that the inlet and outlet temperature of the heat exchanger can be measured at one time. In the field test, Ichikawa et al. (Ichikawa et al., 2008) tested the performance of the air source heat pump with a large capacity installed in an office building in central Tokyo by 27 probing sensors. The velocity of exhaust airflow was measured on each fan unit.

2.2.1.2.2 Air hood method

The air hood is connected to the air outlet of the outdoor unit (Shimuzu et al., 2006), similar to the indoor air hood method. The average inlet/outlet air parameters (temperature and humidity) and airspeed distribution were measured and calculated. Compared with the air sampling method, the interference of the outdoor environment is avoided with better airflow uniformity.

A rectangular duct is set at the air outlet of the outdoor unit to measure heat exchange by temperature and humidity sensor. Figure 2.2.1-4 shows the outdoor unit's duct part and vector velocity distribution. The airflow within the duct is a swirling flow. Velocity components primarily influence the thermal distribution and make accurate measurements challenging.

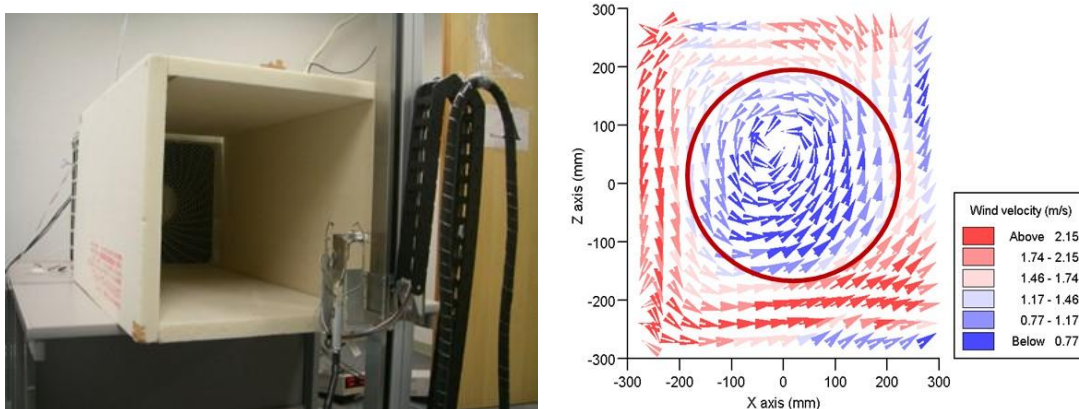

Figure 2.2.1-4. Duct in the outdoor unit and vector velocity distribution

However, installing an air hood affects the air distribution of the air flow field of outdoor units, especially for the multiple outdoor units. The relative error of this method is about $\pm 15\%$.

2.2.1.2.3 Static outlet air sampling method

By installing of air outlet sampling devices at the outlet of the outdoor unit, the sampling devices obtain the temperature, humidity, and airflow parameters at the microelement (Shimuzu et al., 2007). In order to improve the accuracy, the cooling capacity algorithm was improved. A sampling device that samples the exhaust heat from an outdoor unit was developed by Haga et al. (Haga et al., 2007), which was called the thermal flux sampler. An illustration of the thermal flux sampler is shown in Figure 2.2.1-5. The average mean error was 12% compared with the heat balance method, which shows a great improvement in

evaluating the actual performance of the VRF system. However, considering the complex structure of the measuring device, the installation of the measuring device is complex. In addition, it is necessary to introduce the outlet angle and flow correction coefficient, showing with significant uncertainties.

2.2.1.2.4 Dynamic outlet air sampling method

To solve the problems of difficult installation and complex debugging of the outdoor unit static outlet air sampling method, Zhao (Zhao, 2009) proposed the dynamic outlet air sampling method, which used sensors connected with a rotating rod on a rotating shaft driven by the stepping motor moving at a predetermined speed (Figure 2.2.1.6). The total cooling capacity was obtained by the accumulation of a sub-zone heat transfer.

The mechanical automatic control device complemented the measurement progress, avoiding the anthropic factors' effects. The measurement cost increased significantly for the cost of motor and control devices. Moreover, it is not convenient to install the equipment in some cases, which also restricts the application of this method.



Figure 2.2.1-5. Static outlet air sampling device

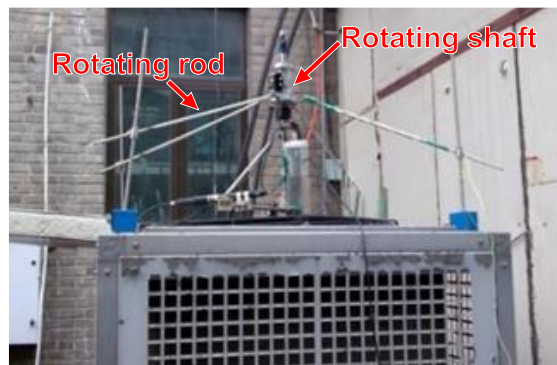

Figure 2.2.1-6. Dynamic outlet air sampling device

2.2.1.3 Refrigerant specific enthalpy difference method

2.2.1.3.1 Compressor performance curve method

Based on the provided information, the compressor performance curve method calculates the refrigerant mass flow rate by fitting a polynomial to some directly measured parameters such as evaporation temperature, condensation temperature, adiabatic compression index and compressor frequency. The polynomial is then applied to the actual operating conditions, and the refrigerant mass flow rate under the corresponding operating conditions is calculated. The cooling/heating capacity of the system is determined by calculating the enthalpy difference between the refrigerant inlet and outlet of the indoor heat exchanger. Related studies prove that the relative errors with approximated and measured refrigerant mass flow rate values are within 6~10% (Takahashi et al., 2008).

However, the compressor performance curve method relies on the fundamental information supplied by the manufacturer. In addition, after the long-term operation, some problems, such as compressor’s wear and tear, and refrigerant leakage, will affect the compressor’s performance. The field performance of the compressor will deviate from the initial performance in the laboratory, showing low accuracy in a long-term test.

2.2.1.3.2 Compressor volumetric efficiency (CVE) method

The ratio of the actual suction volume to the theoretical suction volume is used to define the volumetric efficiency of the compressor (Naruhiro&Shigeki, 2012). As a result, once the volumetric efficiency and structure of the compressor are determined, the refrigerant mass flow rate (or cylinder volume) may be calculated according to Equation (2.2.1.1).

$$\dot{m}_{ref} = \rho_{ref} \times \eta_v \times V_d \times f \tag{2.2.1.1}$$

Where, η_v represents volumetric efficiency, V_d is the actual suction volume of the compressor (m^3/rev), and f represents the frequency of the compressor (Hz). The volumetric efficiency value can be experimentally determined from the air conditioning capacity in a high-precision environmental test laboratory. Figure 2.2.1-7 shows the volumetric efficiency of a scroll compressor obtained using this technique. The error factors and their approximate values for the simplified compressor curve method are shown in Table 2.2.1-1. The total error is over 20%, but since each factor is an independent event, the overall error is within 10%. The disadvantage of the compressor curve method is that the error increases during transient operating conditions, such as when the compressor starts up. However, the error during steady operation is small, and it can be said to be a sufficiently practical evaluation method. In addition, the accuracy of this method depends on the precision of volumetric efficiency, which may be affected by the wear and deterioration of the compressor during a long-term operation.

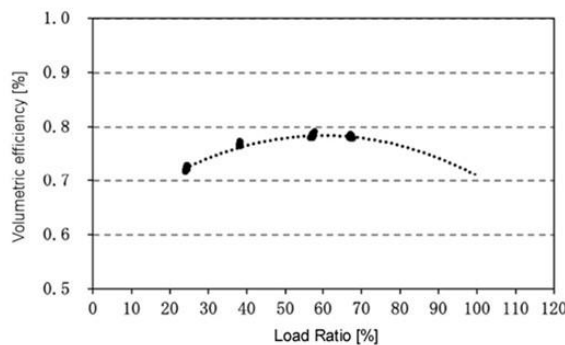

Figure 2.2.1-7. Volumetric efficiency

Table 2.2.1-1. Error factors in the compressor curve method

Causal factors	Individual differences	During operation	
		Cooling	Heating
Variability in Compressor Individual Performance	within $\pm 5\%$	within $\pm 2.5\%$	within $\pm 2.5\%$
Approximation Error in Compressor Performance Characteristics	within $\pm 5\%$	within $\pm 5\%$	within $\pm 5\%$
Four-way valve leakage		within $\pm 0.5\%$	within $\pm 0.5\%$
Sensor errors		$\pm 0.5\%$ each	$\pm 0.5\%$ each
Heat dissipation losses (Liquid piping)		within 2-3%	

2.2.1.3.3 Refrigerant mass flow meters method

The intrusive measurements on the refrigerant side can directly obtain the refrigerant mass flow. Teodorese et al. (Teodorese et al., 2007) determined the refrigerant flow rate by using the Coriolis flow meter installed at the exhaust side of the indoor unit during the heating season. Tran et al. (Tran et al., 2012) used two mass flow meters (Coriolis flow meter and external ultrasonic flow meter) in the laboratory to evaluate the flow rate and vapor quality of the refrigerant. It is shown that the averaged relative error of the method even reaches to 1.8% compared with water enthalpy method during a long period field test. However, the Coriolis flow meter is expensive, and it is inevitably intrusive, which will seriously affect the operation state of a heat pump. In addition, the accuracy of the Coriolis flow meter is significantly reduced when inlet refrigerant is in a two-phase or non-steady state.

2.2.1.3.4 Throttling model method

According to the throttling characteristic equation for a compressible fluid, the Throttling Model Method determines the mass flow rate of the refrigerant based on the compressible fluid throttling characteristic equation. Kim & Braun (2016) investigated three different virtual refrigerant mass flow sensors (VRMF) that use mathematical models to estimate flow rate, including the compressor map method, energy balance method, and empirical correlated throttling model method. According to experiments, the three VRMFs work well in estimating refrigerant mass flow rate for various systems with less than 5% root-mean-square error.

2.2.1.3.5 Compressor energy conservation (CEC) method

First proposed by Fahlén (1989), the compressor energy conservation method measures the refrigerant mass flowrate across the compressor based on the energy conservation equation, shown as Equation (2.2.1.2).

$$\dot{m}_{ref}h_{suc} + P_{com} = \dot{m}_{ref}h_{dis} + \dot{Q}_{loss} \quad (2.2.1.2)$$

where, \dot{m}_{ref} represents refrigerant mass flow rate across the compressor, in kg/s; h_{suc} and h_{dis} represent the refrigerant specific enthalpy at compressor suction and discharge port, in kJ/kg; P_{com} represents electric power input, in kW; \dot{Q}_{loss} represents heat loss between compressor and surrounding, in kW.

For a room air conditioner where the refrigerant mass flow rate across the compressor equals that across all indoor units, the CEC method can be directly applied to obtain the field performance. However, for a VRF system with multiple circuits, such as oil return and subcooling circuits, the refrigerant mass flowrate across the compressor does not necessarily equal to that across all indoor units. In this case, the compressor set energy conservation (CSEC) method is proposed by Zhang et al. (Zhang et al., 2019) to solve this problem. Further, to cope with the two-phase suction situation and increase the method's accuracy, the CEC-CVE method is proposed to improve the measurement accuracy in two-phase suction condition (Yang et al., 2020; Xiao et al., 2022). The accuracy of this method is finally proved to be approximately 15% compared with the AE method. This method shows long-term reliability, independence, and non-interference, which are significant requirements for field tests.

2.2.2 Air-water (hydronic) heat pumps

Previous measurement methods (AE and RE methods) can be applied with similar principles for air-water heat pumps. In addition, the water side method is available for performance measurement cases where the water side is accessible. The water flow rate and temperature can be accurately measured using a mass

flow meter and temperature sensor. Heat transfer of the outdoor unit is determined accurately from the water side by Equation (2.2.2.1). In addition, after measuring the compressor's power consumption, the total cooling capacity is calculated by Equation (2.2.2.2), and the total heating capacity is calculated by Equation (2.2.2.3).

$$\dot{Q}_{out,w} = \dot{G}_w c_{pw} (t_{w,in} - t_{w,out}) \quad (2.2.2.1)$$

$$\dot{Q}_{in,c} = \dot{Q}_{out,w} - P_{com} \quad (2.2.2.2)$$

$$\dot{Q}_{in,h} = \dot{Q}_{out,w} + P_{com} \quad (2.2.2.3)$$

In summary, the AE and RE methods are available approaches to measure heat pump performance. Among these methods, the CEC method is better for its long-term reliability, independence, and non-interference. In addition, for the short-term measurement of new heat pump products (with slight efficiency deterioration), the CVE method is a practical choice. Thus, combining these two methods to realise high-accuracy measurements for heat pumps during their life-cycle may be a promising approach.

2.3 Existing standards and protocols for monitoring methods for heat pump systems

2.3.1 China's specifications and standards

Standardisation is an important way to promote the development and application of the technology. Previous standards in China for the performance testing of heat pump (mainly refer to RAC and VRF system) mainly concentrate on the operating performance in the laboratory, but there are also corresponding specifications for the measurement of the on-site operating performance.

In the regulation produced by Architectural Services Department of the Hong Kong Special Administrative Region (Architectural Services Department, 2007), it required that the air-conditioning system (including the central air system and split air system) should be tested by air enthalpy method in a short time, and the unit should keep full loads in the steady state. Since this regulation is not dedicated to the field test, related technical schemes are not illustrated in detail.

To promote the CEC method, the standard T/CAS 305-2018 "Specification for measurement of on-site performance parameters of air conditioner" (AQSIQ, 2018) was proposed firstly in China, including calculation formulas, installation positions of sensors, and accuracies & calibrations of measuring devices. For air conditioners without pressure sensors, temperature sensors are used to estimate the evaporation/condensation pressure in CEC method. In addition, APF index reflecting the seasonal performance of the unit specified in the energy efficiency standard (e.g. GB 21455-2013 (AQSIQ, 2013)) are used to evaluate accuracy of the measurement device, as shown in Table 2.3.1-1. Through the measurement under the different operating conditions, the tested APF of measuring devices was compared with the results of the psychrometric calorimetric laboratory APF_{IPME} , and the relative error of the two measurement results δ_{IPME} (calculated by Equation (2.3.1.1)) is adopted as the accuracy evaluation index. Based on the measurement results, the accuracy of the measurement device is classified. APF with a relative error of less than 10% can be regarded as a high-precision field performance measuring device, while a measuring device with a relative error of more than 25% is regarded as unqualified.

Table 2.3.1-1. Accuracy calibration conditions of measuring device

Item	Calibration condition				Test item	Necessity	
	Indoor side		Outdoor side				
	DBT	WBT	DBT	WBT			
Cooling	Nominal cooling	27	19	35	24	Nominal cooling	○
						Half cooling	○
						25% cooling	○/△
	Low temperature cooling	27	19	29	—	Low temperature	○
	Low humidity cooling	27	<16	29	—	Low humidity	△
	Intermittent cooling	27	<16	29	—	Intermittent cooling	△
	Maximum cooling	32	23	43	26	Maximum cooling	△
Extreme high-temperature	32	23	48	—	Extreme high-temp.	△	
Heating	Nominal heating	20	—	7	6	Nominal heating	○
						Half heating	○
						25% heating	○/△
	Intermittent heating					Intermittent heating	△
	Low-temperature heating	20	≤15	2	1	Low temperature	○
	Extreme low-temperature	20	≤15	-7	-8	Extreme low-temp.	○

Note: ○ represent the necessary item, and △ represent the selected item.

$$\delta_{IPME} = \frac{|APF_{IPME} - APF_S|}{APF_S} \times 100\% \quad (2.3.1.1)$$

In recent years, VRF systems have been widely used with increasing demands in the market. In China, the standard T/CECS “Technical specification for the retrofitting of multi-connected split air condition system” (C.A. of B. Research, 2019) and standard for T/CECS 846-2021 “Performance testing of heating and air-conditioning system in hot summer and cold winter zone” (C.A. of B. Research, 2021) published by the China Association for Engineering Construction Standardisation aims to determine the method and regulations of VRF renewal and retrofitting. In this standard, four classes were determined when considered renewal and retrofitting, including air condition system function, security, environment, and energy efficiency. To acquire the energy efficiency of heat pump, the indoor AE method was recommended to adopt for the cooling/heating capacity of VRF system. In these two standards, the compressor set energy conservation (CSEC) method is included as an available method. The schematic of sensors installation by CSEC method on VRF system is shown in Figure 2.3.1.1. By testing the temperature, pressure and energy consumption, cooling or heating performance of a VRF is finally calculated. In addition, the waterside heat metering method is also recommended for water source VRF system. Therefore, through the standard for retrofit VRF system, the field test methods and related principles are determined, which contribute to the promotion of high-efficiency VRF system in energy-saving transformation projects.

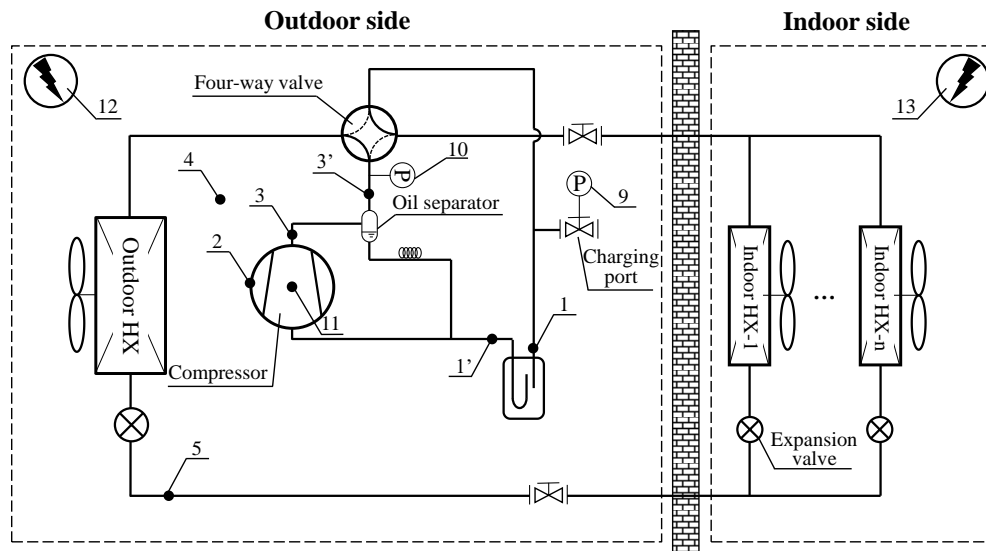

Figure 2.3.1-1. Schematic of sensors installation by CESC method on VRF system

1—Inlet refrigerant temperature of liquid separator; 1'— Outlet refrigerant temperature of liquid separator; 2—Refrigerant temperature in the middle of compressor (or external insulation); 3—Refrigerant temperature of compressor discharge; 3'—Outlet refrigerant temperature of oil separator; 4—Outdoor air temperature; 5— Inlet (in heating mode) or outlet (in cooling mode) refrigerant temperature of outdoor heat exchanger; 9—Inlet pressure of liquid separator; 10—Discharge pressure of compressor; 11—Compressor input power; 12— Energy consumption recorded by outdoor energy meter; 13—Energy consumption recorded by indoor energy meter

In China, performance measurements of heat pumps are receiving increasing attention. Standards incorporating performance measurement techniques currently under development also include T/CECS “Standard for field measurement of energy efficiency and energy saving of multi split air conditioning (heat pump) system” and GB/T 27941 “Code of design and installation for multi split air conditioning (heat pump) system”. To verify the consistent accuracy of the performance measuring device during the test, the former one proposed the calibration method under continuous dynamic condition. In addition, The GB/T 27941 standard (Chinese Standards, 2011), which is under revision, plans to apply performance measurement methods to test the effectiveness and acceptance of installed VRF systems.

2.3.2 Canada’s specifications

In 2020-2022, Natural Resources Canada funded field trials of air to air, variable capacity cold climate heat pumps in locations across Canada. To provide guidance for these field tests, a technical guideline for field monitoring was developed (Natural Resources Canada, 2022). The Guideline covers 4 planning and undertaking field monitoring aspects, including site and equipment selection, monitoring parameters, short-term testing and long-term testing.

In the first aspect of site and equipment selection, basic information is collected and reported, such as geographical location, house description and use, house heat load, heating and cooling system configuration, system sizing calculations and other details.

In the second aspect, parameters and accuracy in the testing are regulated. Required data mainly includes: whole-house power/energy, system power/energy of outdoor unit and indoor unit(s), backup heat power/energy for the area being heated by the ASHP, outdoor air temperature and humidity, indoor air temperature and humidity, location of outdoor unit, supply and return air temperature, relative humidity at return and supply, indoor unit air flow rate, ventilation air flowrates and temperatures, system runtime during the measurement interval, any unit controls, sensors, or outputs that can be accessed and recorded.

In short-term testing, HP system is set to provide maximum cooling or heating depending on the season. The above parameters are monitored, and the supply air flow rate is calculated according to the fan curve.

The efficiency of HP is measured according to the indoor side AE difference method. The tested capacity, power consumption, and supply conditions are compared with manufacturer submittals or engineering data sheets. The monitoring measurements, when applied correctly, are expected to result in load calculations that are accurate within $\pm 20\%$, compared to manufacturer data. If any measured performance value is more than 20% off the expected value, double-check sensor performance.

In long-term testing, performance of HP is measured in similar method during a long term. During the testing, periods when the heat pump are off, standby and active mode (cycling on and cycling off) should be recorded to see how well the heat pump matches the heating load of the house. In “Active mode”: the heat pump is the selected heating/cooling system (switched ON) and provides heat/cooling in cycling on or cycling off state. In “Standby mode”: the heat pump is the selected heating system (switched ON) and not providing the heat, as there is no cooling or heating load. In “Off mode”: the heat pump is not the selected heating system (switched OFF) and not providing the heat, but draws electricity.

By counting the temperature bin hours, seasonal performance factor is calculated. For example, Seasonal Coefficient of Performance Calculations in heating season ($SCOP_H$) should be calculated according to Equation (2.3.2.1).

$$SCOP_H = \frac{\sum_{j=1}^{j=N} [Load(T_j) \cdot \frac{j}{N}]}{\sum_{j=1}^{j=N} \left[\left(\frac{Capacity(T_j)}{COP(T)} + Aux(T_j) \right) \frac{n_j}{N} \right] + P_{HNA}} \quad (2.3.2.1)$$

Where, Aux represents electrical power required for auxiliary space heating (kWh); P_{HNA} represents the power consumed when the unit is not in active mode (kWh); n_j/N represents the ratio of the number of data records collected for the bin temperature (T_j) to the total number of data records in the heating season.

2.3.3 US's specifications

ASHRAE Standard 221 (ANSI/ASHRAE, 2020). provides a method to field measure and estimate the capacity and efficiency and score the performance of an installed HVAC system. The standard applies to single-zone unitary split and packaged direct expansion cooling, air-source heat pump, and combustion furnace HVAC systems of any capacity and with forced-air distribution systems. It provides uniform methods of measurements and testing procedures for airflow, temperature, enthalpy, and power. Moreover, test instruments, specifications, and calibration requirements for capacity and efficiency measurements are specified in this standard.

The standard adopts indoor side AE difference method in field test. Test instruments include air balancing (capture) hood assembly, digital anemometer, manometers (for air pressure measurement), multisensory thermometer/psychrometer and electrical power meter. Corresponding specifications of the instruments are specified. In testing procedure, air balancing hood and thermal (or rotating vane) anemometer are used to measure the airflow of indoor terminal (shown as Figure 2.3.3-1). A digital thermometer or psychrometer probe is used to measure air temperature or enthalpy (shown as Figure 2.3.3-2). For the cooling system, temperature and humidity measurement are required to finish a minimum of seven readings at different locations simultaneously and displaying or recording each value, including wet-bulb and dry-bulb temperatures. For heating system, a similar requirement is specified for dry-bulb temperature measurement. Averaged values of temperature and enthalpy are used in capacity calculation.

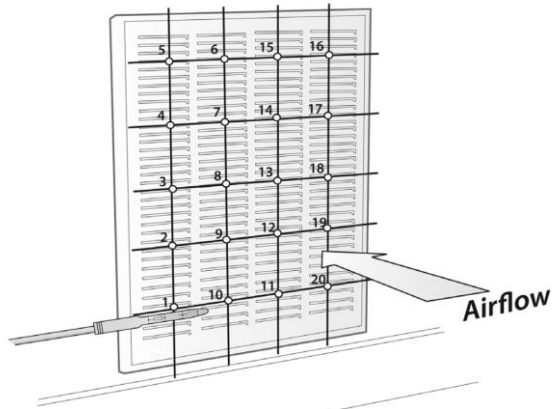

Figure 2.3.3-1. Airflow measurement procedure

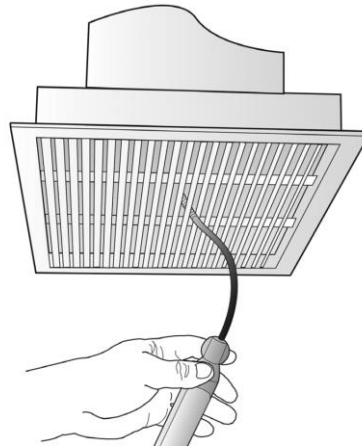

Figure 2.3.3-2. Air temperature or enthalpy measurement procedure

Based on the tested cooling or heating capacity as well as electrical consumption, the standard provides calculation method for system efficiency scoring indexes. Installed cooling system EER (ICS-eer) and installed cooling System COP (ICS-cop) represent the ratio of the total capacity delivered through the supply registers and return grilles divided into the measured total power consumed by the system and normalised to standard rating conditions.

2.3.4 Europe's specifications

For the air-to-air unit, Finnish standards NT VVS 115 (NORDTEST, 1997a) and NT VVS 116 (NORDTEST, 1997b) specify the working conditions and measurement methods for on-site performance measurement of air-to-air units, including the measurement of the compressor suction and discharge temperature and pressure, condenser outlet temperature and compressor power. The performance data of the heat pump are obtained by CEC method. Figure 2.3.4-1 shows the symbols used to define the refrigerant states which are necessary to calculate performance data. Figure 2.3.4-2 presents the basic principle of CEC method, and the heat losses were expressed as a fraction of the power input to the compressor in NT VVS 116.

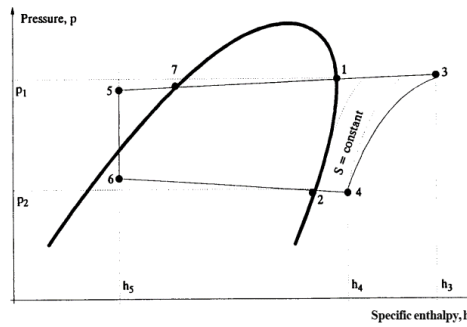

Figure 2.3.4-1. Designation of refrigerant states

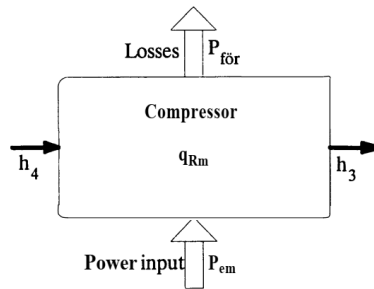

Figure 2.3.4-2. Thermal balance of the compressor

2.4 Existing data on monitored energy efficiency of heat pump systems and comparison with laboratory test results

2.4.1 Case 1 (VRF)

To investigate the actual performance parameters of the VRF system, Zhang (Zhang, 2020) measured the cooling capacities of 6 VRF systems in a building in Hefei, China (VRF S1/S2/S4/S5/S6 identical with a 16 kW capacity, VRF S3 is different with a 12.5 kW capacity). During the 90-day testing period, the average daily cooling capacity of 6 VRF systems is distributed within 1.4~6.6MJ/(d·m²). Among the 6 VRFs, S5 VRF shows the largest daily average cooling capacity because it operated for 702 h during the measurement period, as shown in Figure 2.4.1-1. In addition, the cumulative operation time of S2 VRF, with the smallest daily average cooling capacity, is about 164h. In addition, the hourly average cooling capacity of S1 and S5 VRF is higher than the corresponding rated capacity, indicating that the actual load of the rooms of the two systems could be higher than the designed load.

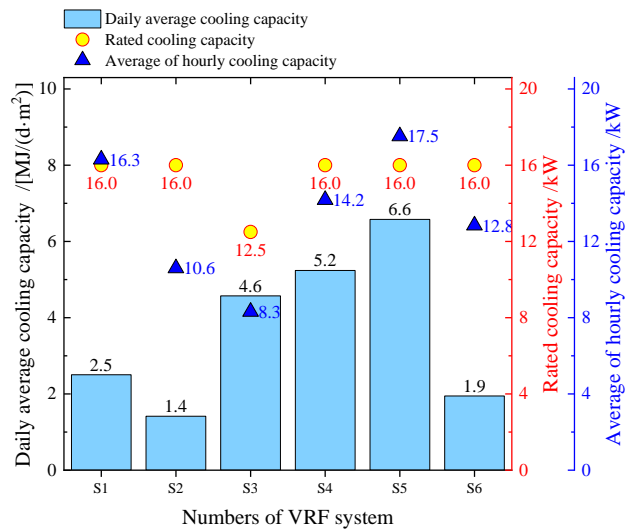

Figure 2.4.1-1. Cooling capacities of 6 VRF system

Figure 2.4.1-2 shows the statistical results of operation hours of the 6 VRFs at different part load rate during the testing period, and the result show different distribution patterns. In the field test, the periods when the part load rate of S1, S4 and S5 VRF is higher than 0.8 accounted for approximately 86%, 74% and 94%, respectively. Moreover, the part load rate of S3 VRF concentrates between 0.4 and 0.8, which accounts for approximately 87% of the total operation hours. For S2 and S6 VRF, the system operates at a relatively wide range of part load rates. Thus, the distribution pattern of operation hours on part load rate indicates that the actual operation conditions and performance of VRFs could be quite different. In addition, more attention should be paid to system design and sizing to ensure that the system operates in an appropriate and efficient part load rate area.

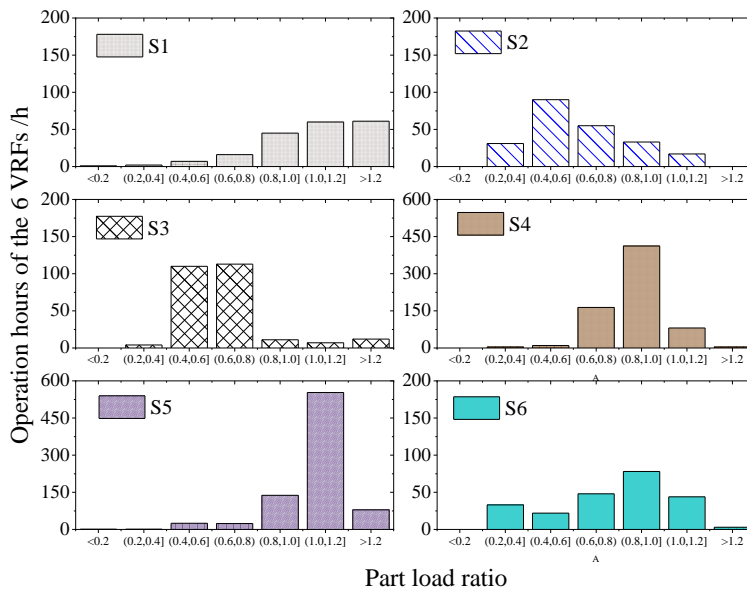

Figure 2.4.1-2. Part load rate and operation hours of the 6 VRFs

Table 2.4.1-1 shows the actual cooling operating parameters of the monitored VRF. The average power consumption of the six VRFs during the 90-day monitoring period ranged from 2.0 kW to 5.0 kW. Meanwhile, EERs were distributed in the range from 3.41 kWh/kWh to 4.08 kWh/kWh. Moreover, the average part load rate of S1 and S5 is higher than 1.0.

Table 2.4.1-1. Actual operating parameter of monitored VRFs

System code	S1	S2	S3	S4	S5	S6
Average outdoor DBT /°C	34.6	33.4	35.1	34.5	34.4	35.1
Average indoor DBT /°C	25.1	27.3	27.3	25.7	24.6	26.1
Average outdoor WBT /°C	20.2	21.4	20.9	21.5	20.3	21.3
Number of IUs	3	3	3	4	4	3
Main pipe length /m	14.7	29.7	24.1	41.7	9.7	9.7
Average power consumption /kW	4.5	2.7	2.0	4.2	5.0	3.4
Average cooling capacity /kW	16.3	10.6	8.3	14.2	17.5	12.8
Average part load rate /(kWh/kWh)	1.03	0.66	0.53	0.89	1.09	0.81
EER during testing period /(kWh/kWh)	3.66	3.98	4.08	3.41	3.49	3.75

2.4.2 Case 2 (VRF)

As part of Japan's Ministry of the Environment's CO₂ reduction project in Japan, a nationwide field test of VRF systems was conducted in 2018 at 15 locations. The VRF units used for the tests were all products from the same manufacturer, with a rated COP in the range of approximately 4.1 to 4.3 (in cooling operation). These field tests were conducted in the country's northern region (cold climate) and the central region (temperate climate). Data collection for analysis was performed using a newly developed device shown in Figure 2.4.2-1. This device sends operational data from the outdoor unit's control panel to a cloud server. On the cloud server, real-time calculations of VRF performance and other metrics are performed based on the transmitted data. The main analysis results related to the energy performance of VRF are as follows.

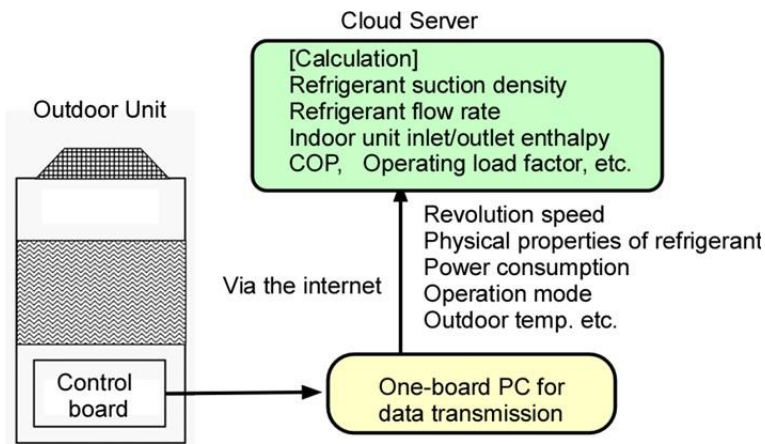

Figure 2.4.2-1. Data collection device

Table 2.4.2-1 shows the climate zone-specific average COP and average load ratio (actual capacity / nominal capacity) during heating and cooling in the field tests. The average load ratios are low, especially in the northern area (cold climate) where it is 19.6%, indicating prolonged low-load operation due to oversized equipment capacity. Generally, VRF systems are designed to achieve peak efficiency at load ratios approximately 50% to 60%, so inefficient operation at low load ranges decreases in COP.

Table 2.4.2-1. Average load ratio and COP

Operation	Northern Area		Central Area	
	Cooling	Heating	Cooling	Heating
Ave. Load ratio (%)	22.3	19.6	33.6	23.8
Av. COP	2.4	1.7	2.9	1.9
Rated COP ratio (%)	58.5	41.5	70.7	46.3

As in Figure 2.4.2-2, when outdoor units are installed nearby, the exhaust heat from the condenser of Unit B can reach the neighbouring outdoor unit (A), causing a decrease in its COP. With a temperature difference of 20°C between the exhaust and outdoor air temperature, the COP decreases by approximately 21%. As a countermeasure, installing a shielding panel between Unit A and Unit B eliminates the interference of exhaust heat, making the COP of Unit A almost equivalent to that of Unit B.

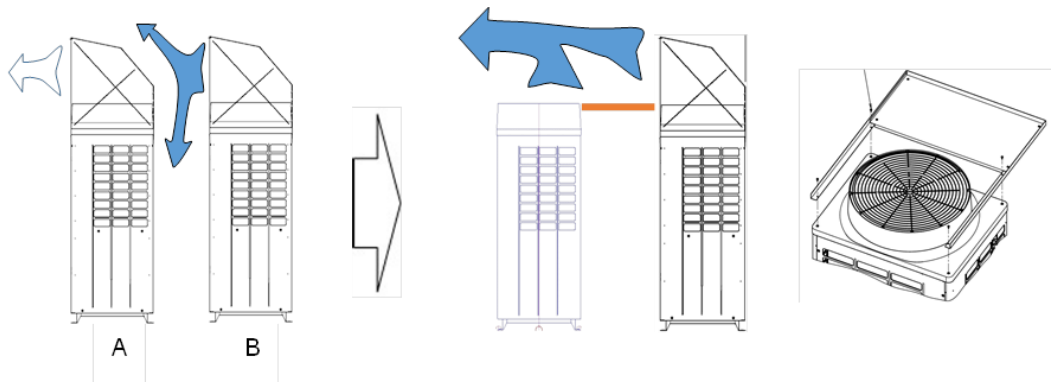

Figure 2.4.2-2. Impact of Exhaust Heat Short-circuit

The behaviour, power consumption, indoor unit suction air temperature, outside temperature, and COP values during defrost operation in winter heating are illustrated in Figure 2.4.2-3. Power consumption sharply increases at the onset of defrost operation, temporarily reaching approximately twice the rated power consumption. Defrost operation occurs at a frequency of approximately once every two hours after the start of operation. When defrost operation is performed, the average COP value for the same day is typically reduced by approximately 55% compared to normal operation.

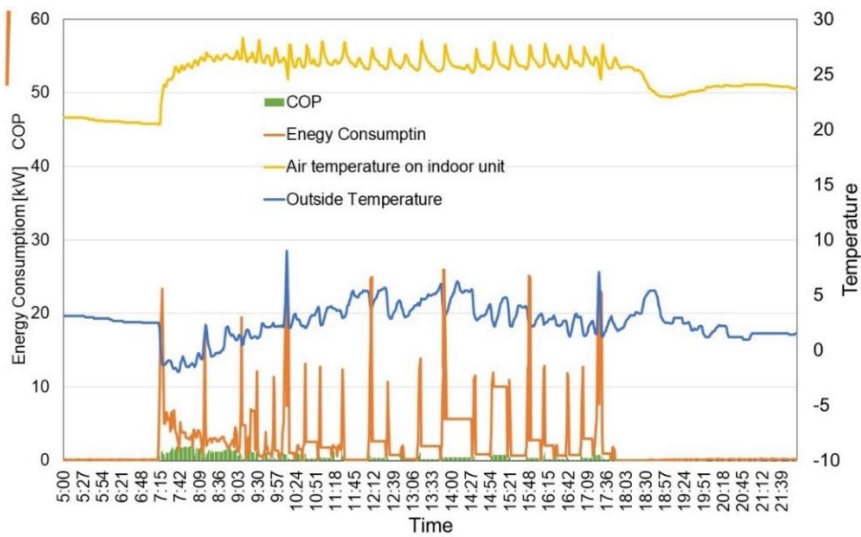

Figure 2.4.2-3. Defrost during heating operation

Since VRF has multiple indoor units connected to one outdoor unit, it accommodates the capacity demands of indoor units with lower set temperatures. Therefore, energy consumption increases compared to when set temperatures are uniform (Figure 2.4.2-4). Table 2.4.2-2 compares average set temperatures, standard deviation, average COP values, and average power consumption per unit of time in both states. The variation in set temperatures leads to a decrease in average COP and an increase in energy consumption by approximately 9%.

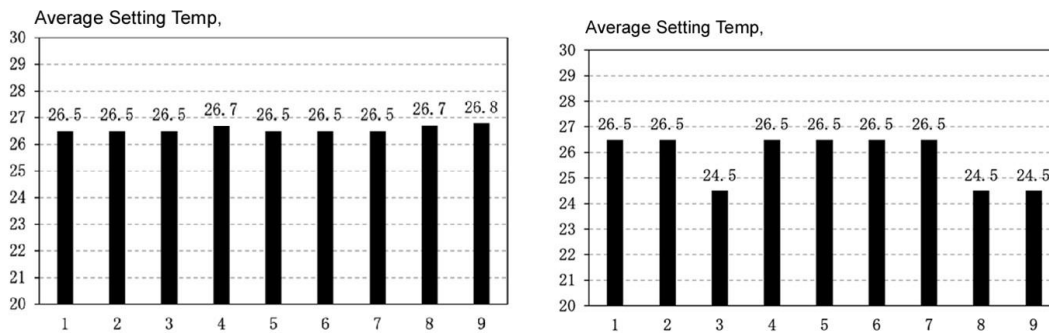

Figure 2.4.2-4. Condition of Indoor Unit Set Temperatures

Table 2.4.2-2. Impact of Variations in Set Temperatures of Indoor Units

Set Temp Condition	Average Set Temp [°C]	Standard Deviation [°C]	Average COP	Percentage change of energy use [%]
Uniform	26.7	0.11	2.54	-
Non-uniform	25.6	0.94	2.26	+8.9

2.4.3 Case 3 (RAC)

A follow-up project was carried out in 2011 (Building Research Institute, 2011) the project, three major Japanese manufacturers of RACs and a Japanese public testing laboratory (JATL: Japan Air Conditioning and Refrigeration Testing Laboratory) actively joined the dedicated team and provided technical support for measurements that were as accurate and transparent as possible. Four types of RACs were dealt with in the project. Before the field monitoring, the characteristics of the four RACs, especially the relationship between fan frequencies and airflow rates, were tested using the JATL test facility.

For cooling, the frequencies of appearance of the partial load ratio and COP for each range of the partial load ratio are shown in Figure 2.4.3-1. Seasonal average COPs written in the figure are the ratios of the

total cooling or heating load, which was dealt with by RACs when switched on to the total electricity consumption.

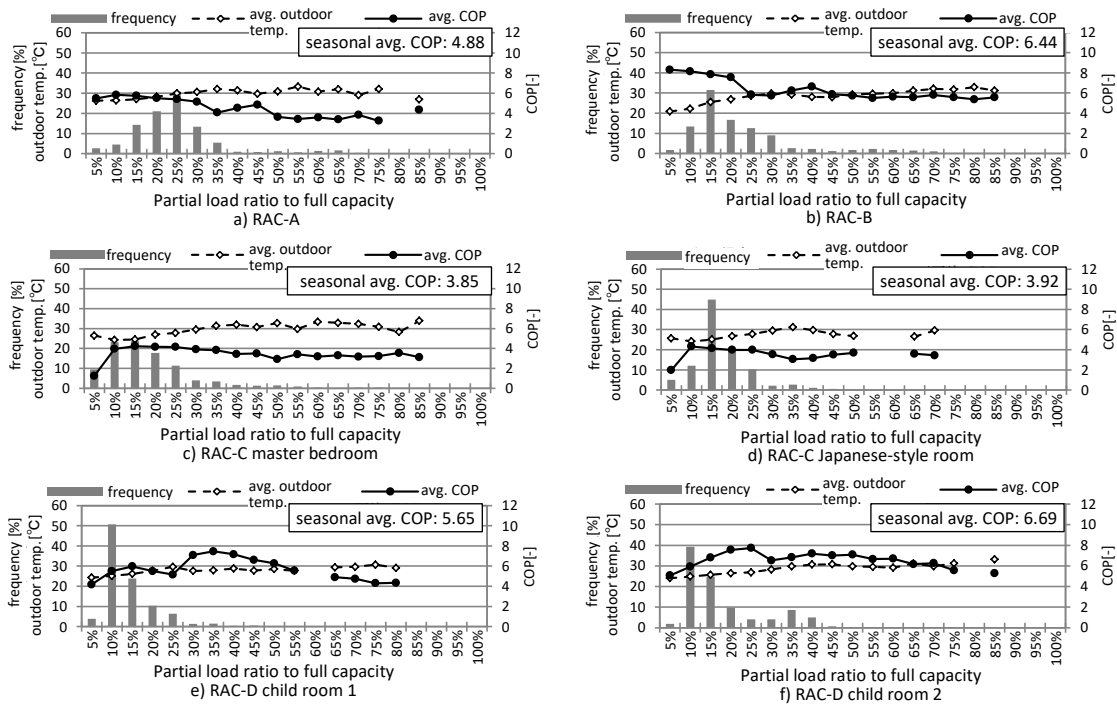

Figure 2.4.3-1. Frequencies of appearance of partial load ratio and COP for each range of the partial load ratio (Cooling)

RAC-A and RAC-B were installed side by side in the living room and were operated alternately every two weeks. The average outdoor temperatures for RAC-A and RAC-B were 29.2 °C and 26.6 °C, respectively. The peak range of appearance of the partial load ratio for RAC-A was 25%, while one for RAC-B was only 15%. For other RACs, frequencies of partial load ratio between 10% and 15% were higher than other ranges, and the actual partial load ratio for RACs used for cooling in a typical Japanese detached house needed to be very low.

On the other hand, the average COP for every 15 minutes under a partial load ratio below 25% was as high as or even higher than one under a partial load ratio above 50%. The COP of RAC-B below the partial load ratio of 20% was especially high, presumably due to lower outdoor temperature.

Figure 2.4.3.2 shows the relationship between partial load ratio and COP for different outdoor temperature ranges for cooling. In the figure, COPs for full capacity, rated capacity, and middle capacity are also plotted. There is a general tendency for COP to decrease under the partial load ratio between 0% and 20% for all monitored RACs. However, for RACs with larger capacity, such as RAC-A and RAC-B, COP could be maintained at the same level, above 20%, even below the partial load ratio of 5%. If the test result of COP for middle capacity (under 35 °C outdoor temperature) is compared with the monitored the actual COP for RAC-A, the actual COP under 33 ± 1.5 °C and 36 ± 1.5 °C outdoor temperature was approximately 30% lower than the test result for the middle capacity. For RAC-C in the second living room and in the main bedroom, the actual COP was approximately 50% lower than the COP for middle capacity, even though actual indoor temperature in those rooms with RAC-C was around 24 °C, which was lower than the set-point temperature for cooling (26 °C) presumably due to the characteristics of the products used in the monitoring. On the contrary, for RAC-D in child room 1, the actual COP under 30 ± 1.5 °C outdoor temperature was only slightly higher than the COP for middle capacity. For RAC-D in child room 2, the actual COP under 33 ± 1.5 °C was almost the same for middle capacity. Therefore, it can be said that the test result for middle capacity (with compressor frequency fixed) of RAC-D could represent actual COP in the monitoring.

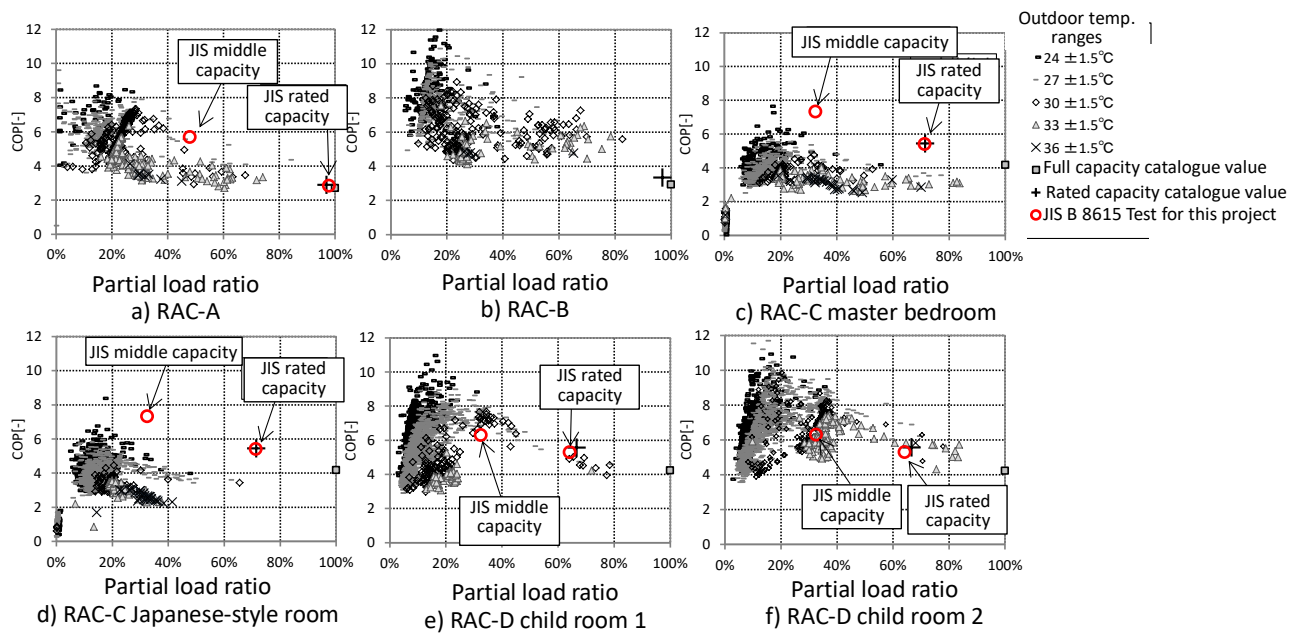

Figure 2.4.3-2. Relationship between partial load ratio and COP for different ranges of outdoor temperature for monitored five RACs (Cooling)

2.4.4 Case 4 (Water-water HP)

For smaller heat pump systems, such as room air conditioners and VRF systems, establishing measurement systems for field monitoring is feasible. However, if the capacity of a monitoring target is several hundred kW or larger, it is not realistic to install additional water flow meters and temperature sensors in existing target systems. However, many large-scale buildings (i.e., 30,000 m² floor area) usually have their building energy management systems (BEMS) with sensors and data logging systems, and there is a possibility to obtain support from relevant stakeholders, namely building owners, HVAC designers, installers of HVAC systems and manufacturers of control systems.

The following case (Ueno et al., 2022, Ueno, 2022) is an office building with a 32,000 m² gloss floor in Tokyo. In this case, the primary motivation of the building owner and the HVAC designers was to engage experts from third parties with neutral standpoints when they evaluated improvements in the energy performance of the building after the energy retrofit, including the replacement of heat and cold sources. Another important factor for successful monitoring and analysis is the reliability of BEMS and that it is carefully designed, installed, and maintained. It is not always possible to use this kind of useful BEMS when we try to analyse the behaviour of HVAC systems, including the characteristics of heat pump systems.

Figure 2.4.4-1 shows the configuration, including those generators and primary water circuits. Figure 2.4.4-2 shows monthly energy consumption for different system components, where energy consumption for heat sources is shown in the blue part at the bottom of each monthly bar.

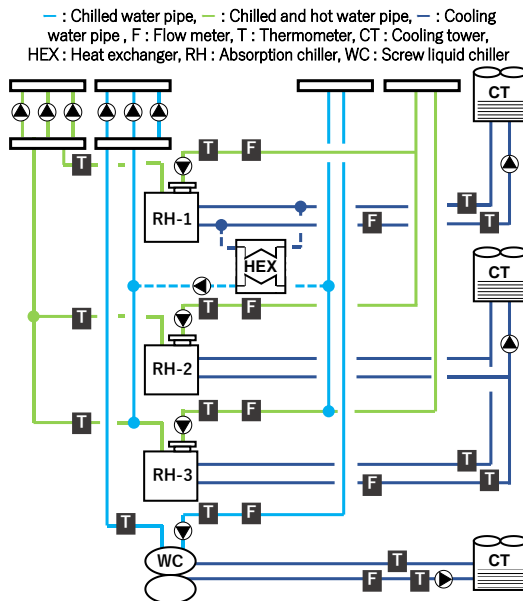

Figure 2.4.4-1. Configuration of heat and cold generators and primary hot and cold water circuit, etc.

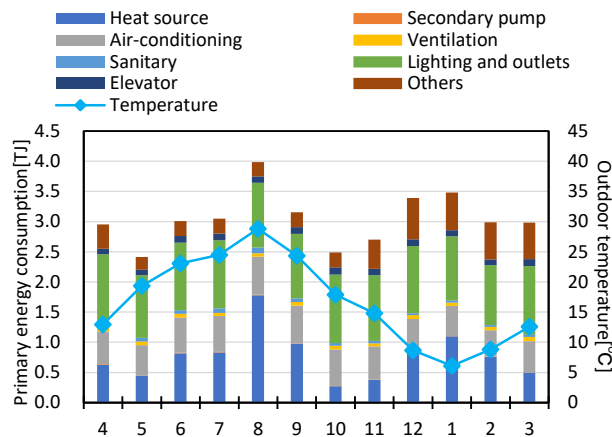

Figure 2.4.4-2. Monthly energy consumption for different components of the energy system

Figure 2.4.4-3 shows the total cooling capacity supplied by the cold sources in the middle season (May) and in the summer season (August). The annual peak of the total hourly cooling load appeared at 9 AM on the day shown as a representative of the summer season in Figure 2.4.4-3. In both seasons, the maximum hourly cooling load appeared at the beginning of the daily operation of the HVAC system. To cope with the cooling load, a screw chiller ('WC' in Figure 2.4.4-1) was primarily operated, and the screw chiller dealt with 58.1 % of the total annual cooling load. Figure 2.4.4-4 shows the cooling load dealt with by each cold generator and cold generator system's COP (primary energy basis with 9760 kJ/kWh and 1 kJ/kJ as primary energy conversion factors for electricity and city gas, respectively) during the same week shown in the previous figure. The cooling load dealt with by each cold generator is calculated by multiplying the temperature difference between the inlet and outlet water temperature and the water flow rate.

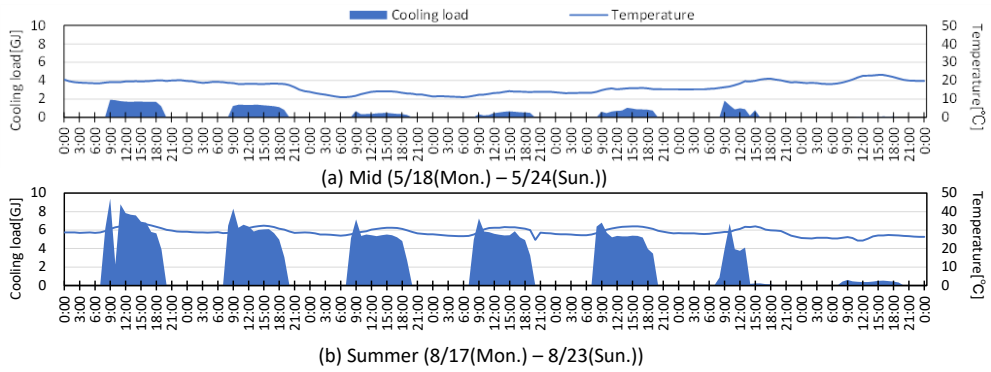

Figure 2.4.4-3. Total cooling load dealt with by the cold generators in a middle season (May) and in a summer season (August)

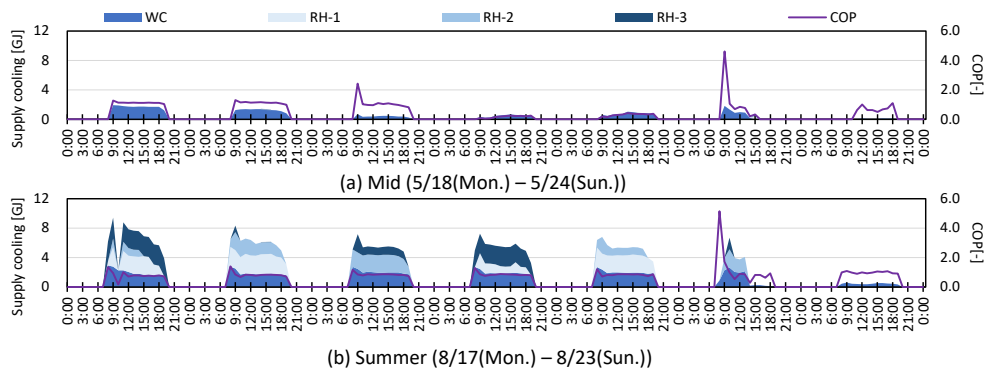
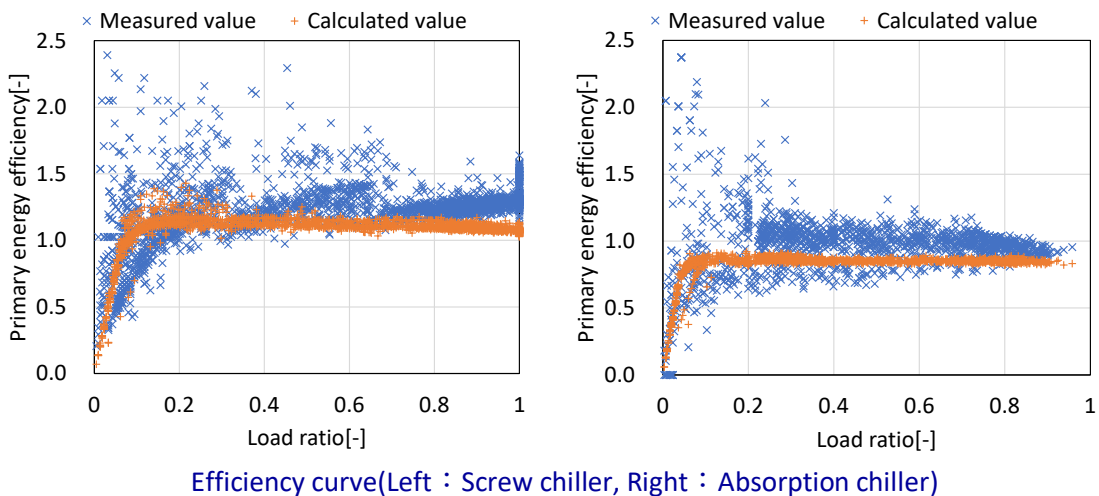

Figure 2.4.4-4. Cooling load dealt with by each cold generator and cold generator system's COP

Figure 2.4.4-5 shows the relationship between COP (primary energy basis) and part load ratio. The data in the figure includes the statuses of the cold sources under different conditions for temperatures of inlet/outlet and cooling water. It is important to notice orange dots, which are predicted COP according to the characteristic curves (as shown in Figure 3.3.4-5 in Chapter 3 in this report) prescribed for BECS's energy use calculation. The rated COPs on a primary energy basis for the two kinds of cold sources are 1.37 for the screw chiller and 1.05 for the absorption chiller system ('RH1', 'RH2', 'RH3' in Figure 2.4.4-1). The difference between predicted COPs around the partial load ratio of 1 and the rated COPs is the usage of so-called adjustment coefficients for capacity (0.95) and input energy (1.2), prescribed for BECS.



Efficiency curve (Left : Screw chiller, Right : Absorption chiller)

Figure 2.4.4-5. Relationship between COP (primary energy basis) and partial load ratio

2.4.5 Case 5 (Water-water HP)

To study the operational efficiency of a MBC-HP (magnetic bearing variable-speed centrifugal heat pump), Deng et al. (Deng et al., 2023) conduct field test on a practical project. As shown in Figure 2.4.5-1, a MBC-HP was applied in a heat exchange station in a municipal central heating system. Where the evaporator-side water of MBC-HP extracted heat from the return water of the primary central heating network through heat exchangers. To decrease the return water temperature of the primary central heating network to increase the heating supply ability of the district heating system, but also reduce water transport energy consumption by increasing the supply and return water temperature difference. Then the MBC-HP supplied heat to the secondary heating network for space heating.

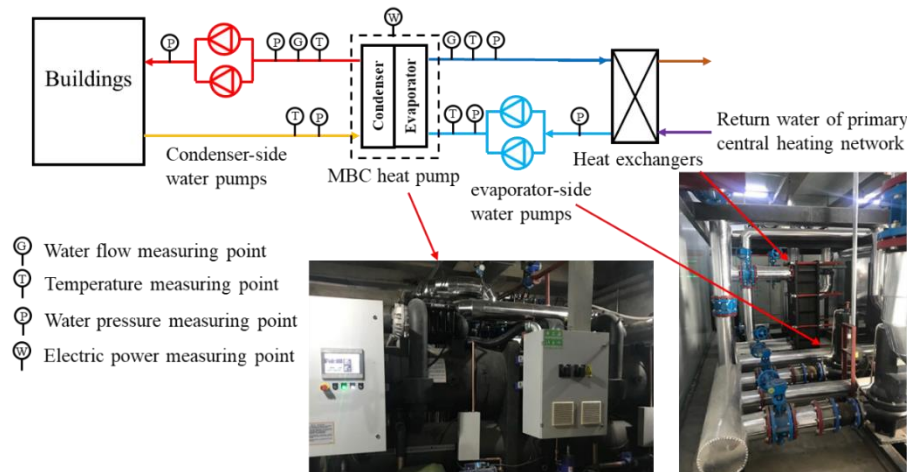

Figure 2.4.5-1. Schematic diagram of the MBC-HP system

Figure 2.4.5-2 shows the hourly heating load of the project, the maximum heating capacity of MBC-HP reached 1004.3 kW with a partial load ratio of 95.2%. Then the heating capacity gradually decreased to about 582.3 kW at the end of the heating season, with a partial load ratio of 55.2%. During 57-days operation, the average heating capacity reached 765.4 kW with an average partial load ratio of 73.0%.

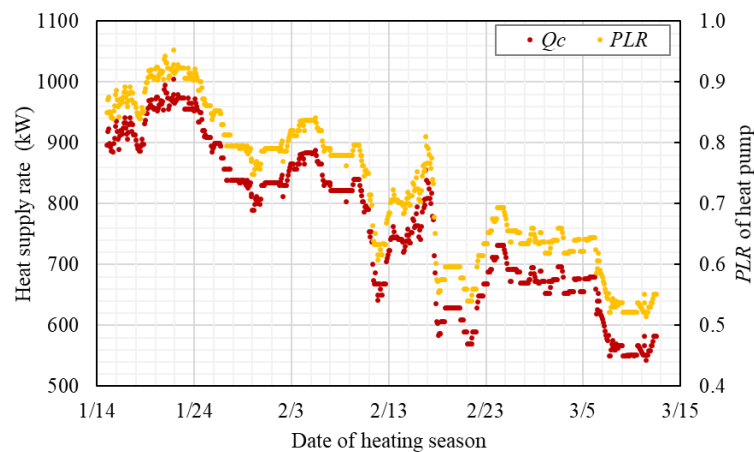

Figure 2.4.5-2. Field-test heating load and part load ratio of MBC-HP

As shown in Figure 2.4.5-3, as the MBC-HP operated in conditions with high evaporator-side water temperature, the COP_t (theoretical COP) reached higher than 9.35. And with the decreasing of $T_{c,o}$ (outlet water temperature of condenser) and increasing of outlet water temperature of evaporator, the condensing temperature decreased and evaporating temperature increased, leading to the obvious increasing of COP_t from 9.35 to 15.87. The high operational COP_t contributes to the high operational COP of MBC-HP. During the field test period, the COP varied from 7.30 to 11.18 with an average value of 8.78.

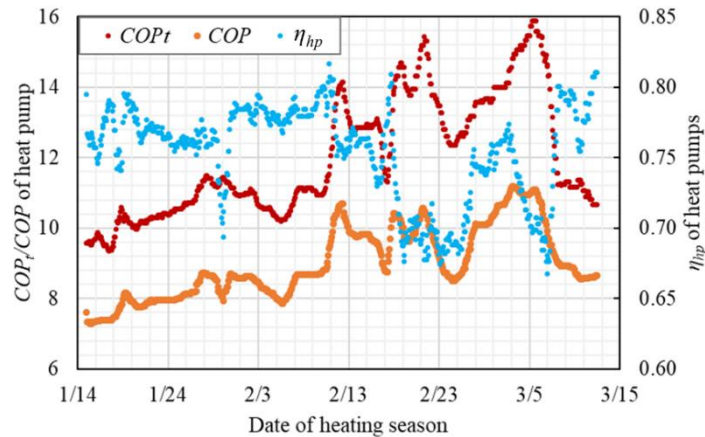

Figure 2.4.5-3. Operational energy performance of MBC-HP

Figure 2.4.5-4 depicts the influence of T_{ce} (normalised temperature difference between condensing and evaporating temperature) and partial load ratio on η_{hp} (internal efficiency of heat pumps) of MBC-HP. The results show that with T_{ce} increasing from 0.30 to 0.80, and PLR (partial load ratio) increasing from 0.40 to 1.0, the η_{hp} increases initially, then gradually decreases. Among the 57-days operation, the average η_{hp} of MBC-HP reached 0.75, with 86.7% of η_{hp} higher than 0.70, 67.5% of η_{hp} higher than 0.75, and 10.3% of η_{hp} higher than 0.78. For the rated performance of MBC-HP, the COP_t of the rated operational conditions reached 7.96. Then, with the rated COP of 5.12, the rated η_{hp} of heat pump reached 0.64. The MBC-HP has higher η_{hp} in conditions with partial PLR and T_{ce} , than the rated condition. Therefore, the MBC-HP has good regulation features, and performed efficiently in conditions with wide-range variation of heating load and compression ratio, which might fit the operation features of MD-GHPs very well.

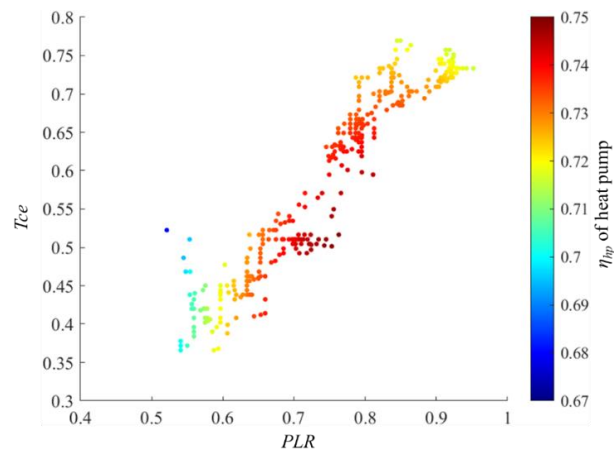

Figure 2.4.5-4. Influence of T_{ce} and PLR on η_{hp} of MBC-HP

2.4.6 Case 6 monitoring projects for air-to-water heat pumps by Fraunhofer ISE

Case 6 to Case 8 are the cases for European projects and the projects conducted in IEA Heat Pumping Technologies TCP. Relevant figures and tables can be obtained through the websites of the projects. Two German monitoring projects are reviewed here. The first one called 'WP Efficiency' was conducted between October 2005 and September 2010 (Miara&Kramer, 2011). The project was conducted by Fraunhofer Institute for Solar Energy Systems (Fraunhofer ISE), half funded by the Federal Ministry of Economics and Technology and was supported financially and technically by seven heat pump manufacturers and two energy supply companies. The project focused on heat pumps in mainly new energy efficient (highly

insulated) residential buildings. Among systems evaluated in the project, 56 ground source to water, 18 air to water and 3 water to water heat pump systems were included. All of them were used for both space heating and domestic hot water.

As a key index, seasonal performance factor (SPF₂), which is calculated as the ratio of the total outputs from a heat pump unit and a back-up heater to the total energy consumption by a fan (or a pump), a back-up heater and a heat pump unit, is used in the report. For air source heat pumps, the annual average seasonal performance factor for three years was 2.89. In the last chapter of the report, detected errors and improvement suggestions for design, installation and operation are described. The chapter touches upon the fact that lower temperature of the heat sink and higher temperature of the heat source is preferable for improving the heat pump's efficiency. It also mentions that the most efficient systems were those which charged the heating circuit directly with no buffer tank.

The second German called 'WP Monitor' was performed from December 2009 to June 2013 and was supported financially and professionally by eleven heat pump manufacturers and an energy supply company. In the report (Günther et al., 2014), mean values and distributions of annual performance values, which were calculated based on JAZZ, the same boundary mentioned above. Hot water temperatures for air-to-water systems were also reported. The average temperature of the hot water provided to the tank for space heating was in the range between 39.8 °C and 27.0 °C, while the average temperature for the domestic hot water tank was in the range between 53.2 °C and 27.0 °C (analysis for 35 air source heat pumps, Figure 32 in the report) (Günther et al., 2014).

2.4.7 Case 7 monitoring projects for air-to-water heat pumps by Eastern Swiss University of Applied Sciences

Recent results of the field measurements of heat pump systems were reported in the Annual report of the project funded by Swiss Federal Office of Energy (Prinzing et al, 2020). The field measurements were conducted by Eastern Swiss University of Applied Sciences in 23 heat pump systems (11 ground heat source systems and 12 air source systems). Only new heat pump systems that were installed mainly in a single-family home (newly built or renovated) were monitored.

Monitored heat pump systems seem to have parallel hot water circuits for domestic hot water and space heating, and they have a hot water tank only for the DHW. There was a description of the use of the electric heating element in the tank as a countermeasure for preventing Legionella disease.

2.4.8 Case 8 IEA Heat Pumping Technologies TCP projects and SEPOMO-Build

IEA HPT Annex 36 'Quality Installation / Quality Maintenance Sensitivity Studies' was launched in November 2010 and closed in November 2013 (IEA, 2014). The Annex 36 aimed at providing useful information to reduce energy usage by encouraging use of quality heat pump installation and maintenance practices to industry, policy makers and building owners/operators. It included Task 3 'Field investigation, Modelling and/or lab-controlled measurements', for which a centralised air-to-air heat pump (by French team), ten Japanese heat pump water heaters (also by French team) and a large-scale field trial of domestic heat pumps for space and water heating (by UK team) were conducted.

The outputs from the Annex 36 should be useful not only for Subtask B2 for monitoring but also for Subtask D for design guidelines, since the Annex was focused on faults to be overcome to improve energy efficiency of heat pump systems.

IEA HPT Annex 37 'Demonstration of Field Measurements of Heat Pump Systems in Buildings, Good Examples with Modern Technology' aimed at presenting examples of domestic heat pump systems with good performance (IEA, 2016). Data from 12 heat pump systems (6 ground source and 6 air source heat pumps installed in the years 2008-2012, 2 among 12 were only for space heating) in residential buildings were analysed in detail to illustrate the principles of design and installation that ensure good performance. Seasonal performance factors, SPF_{H3} and SPF_{H4} (subscripts, H3 and H4 mean boundaries when calculating

seasonal performance factors) were mainly used to express energy performance of the 12 heat pump systems.

Before the Annex 37, a preceding European project called 'SEPEMO' was conducted from 2009 to 2012 (Nordman et al., 2012). The main body of the project included 1) collection and evaluation of past and present field measurements on heat pump systems, 2) evaluation of existing methods for field measurement and calculation of seasonal performance factors, and 3) improvement and extension of existing guidelines for field measurement to include all types of heat pumps. Guidelines for heat pump field measurements were included in the deliverables from the projects (Zottl et al., 2011; Riviere et al., 2011).

IEA HPT Annex 49 'Design and Integration of heat pumps for nearly Zero Energy Buildings' was conducted from October 2016 to May 2020 with its objective for 'field monitoring of marketable and prototype heat pumps in nZEB (IEA, 2020a). In 14 nZEBs plus 3 groups of buildings including residential, office and other non-residential buildings (hotel, kindergarten, school and supermarket), especially larger buildings, monitoring was made. The results from the monitoring projects are reported in Annex 49 Final Report Part 2 (IEA, 2020b). Only one air-source heat pump was monitored, and most targets of the monitoring were ground-source heat pumps. Several general conclusions are described in the concluding chapter, such as the recommendation of heat pumps with variable speed drive, the recommendation of natural refrigerants (e.g., propane, CO₂ and ammonia), the recommendation of utilising surplus heat at different temperature, and the recommendation of heat recovery from surplus heat sources.

IEA HPT Annex 52 'Long-term performance monitoring of GSHP systems for commercial, institutional, and multi-family buildings' was conducted from January 2018 to December 2021 with an aim to survey and create a library of quality long-term performance measurements of GSHP (Ground source heat pump) systems (IEA, 2022a). All types of sources (rock, soil, groundwater, surface water) were included in the scope. The guidelines provided by 'SEPEMO' project were refined and extended in Annex 52 and formalised in guidelines documents (IEA, 2022b; 2021a; 2021b).

2.5 Perspectives of monitoring of actual energy efficiency of heat pump systems and R&D plans in Annex 88

With the goal of energy saving and low carbon emissions, building energy management has raised great attention. As a convenient air-conditioning equipment for space cooling and heating, heat pump is widely used worldwide. To investigate the field performance of heat pumps, much research concentrates on three measurement methodologies, including the water temperature difference method, air-specific enthalpy difference (AE) method, and refrigerant-specific difference (RE) method. For water-cooled VRF, the water temperature difference method can be applied. Meanwhile, for air-to-air VRF, only AE and RE method are accessible in the field performance test. Compared with the AE method, the RE method is more suitable for long-term measurement. According to Section 2.2, field performance test technologies realise better than 25% accuracy at the current state-of-the art. Considering the technical difficulties and random operation in field tests, there are currently methods that can achieve a 10~15% relative error.

The actual performance of the heat pump was investigated by applying different field performance measurement methods in actual buildings. Actual operation characteristics were analysed by measuring and tracking heat pumps installed in actual buildings. In addition, field performance measurement methods were applied in related standards, providing feasible approaches and important indexes for performance testing, evaluation, and system retrofitting.

According to Sections 2.1 to 2.4, further promising research directions on-field performance of heat pumps may include the following five points:

- (1) First, it is necessary to put more efforts into measurement accuracy improvement for all types of heat pumps in different operation conditions. Current studies rarely involve field performance measurement methods in heat recovery mode for heat recovery heat pumps. Measurement

accuracy for heat pump field performance in two-phase suction conditions and dynamic conditions remains to be improved in further studies. In addition, with the demand for individual energy management and individual billing for different terminals and occupants based on cooling/heating capacity, performance metering technology for individual indoor units should be further studied.

- (2) Second, the field performance data provide basic data for related energy policies and standards studies. Through the actual performance of heat pumps, energy-efficient approaches were investigated, which promotes the construction and development of energy policies and standards.
- (3) Third, energy-efficient system evaluation and design methods for heat pumps based on actual performance remain to be studied. Appropriate evaluation methods for field monitoring and lab testing remain to be studied. According to the measurement and evaluation results for the actual performance of heat pumps, problems that decrease field energy efficiency can be discovered. Thus, it is of great significance to improve actual efficiency by optimising system design and sizing methods.
- (4) Fourth, further research on system control, commissioning, and management benefits from actual operation data. Better system control and management strategies that improve actual performance can be investigated. In addition, more economical cooling/heating solutions can be provided to occupants. In addition, field performance tests help determine the actual cooling/heating demand of occupants, which promotes the development of “demand-side response” energy supply conformation and proper consumption of renewable energy in the future. Devices that instantly measure the performance of heat pumps serve as an alternative to heat load sensors in buildings (Heat pump output = Building heat load). By clarifying the relationship between fluctuations in indoor heat load and the heat pump output, it becomes possible to identify the amount of energy saved through various energy-saving measures. This enables the development of precise tuning techniques related to improved energy efficiency.
- (5) Fifth, if users can easily understand the performance and operational status of a heat pump system, it contributes to the improvement of the system by identifying areas for enhancement. For example, in automobiles, installing a globally standardised On-Board Diagnostics (OBD) system is mandatory, allowing relatively straightforward monitoring of operational conditions in various components and facilitating the identification of faults. In the future, it is desirable for heat pump systems also to adopt a common interface similar to OBD for improved system performance.

2.6 References for monitoring methods and database

- ANSI/ASHRAE (2020). ANSI/ASHRAE Standard 221-2020. Test Method to Field-Measure and Score the Cooling and Heating Performance of an Installed Unitary HVAC System, 54 pages.
- AQSIQ. (2013). The Minimum Allowable Values of the Energy Efficiency and Energy Efficiency Grades for Variable Speed Room Air Conditioners (in Chinese). Beijing.
- AQSIQ. (2018). Specification for Measurement of On-Site Performance Parameters of Air Conditioner (in Chinese).
- Architectural Services Department. (2007). Testing and Commissioning Procedure for Air-conditioning, Refrigeration, Ventilation and Central Monitoring & Control System Installation in Government Buildings of the Hong Kong Special Administrative Region (p. 247). The Government of the Hong Kong Special Administrative Region.
- Building Research Institute (2011). Report of Committee for Actual Energy Performance of Room Air Conditioners, 28th February 2011 (in Japanese).
- C.A. of B. Research (2019). Technical Specification for the Retrofitting of Multi-Connected Split Air Conditioning Systems (in Chinese). China.
- C.A. of B. Research (2021). Performance Testing of Heating and Air-Conditioning Systems in Hot Summer and Cold Winter Zones (in Chinese). China.
- Central Air Conditioning Market (2020). China Central Air Conditioning Market Summary Report, (2020) (in Chinese).
- Deng, J.; Su, Y.; Peng, C.; Qiang, W.; Cai, W.; Wei, Q.; Zhang, H. (2023). How to improve the energy performance of mid-deep geothermal heat pump systems: Optimization of heat pump, system

- configuration and control strategy, *Energy*, 285, 129537.
- Enteria, N.; Sawachi, T.; Saito, K. (2023). *Variable Refrigerant Flow Systems: Advances and Applications of VRF*, Springer Singapore, 2023.
- Fahlén, P. (1989). *Capacity Measurement on Heat Pumps - A Simplified Measuring Method*. Swedish Council for Building Research, Sweden.
- Chinese Standards. GB/T 27941-2011 (2011). *Design and Installation Code for Multi-Split Air Conditioning (Heat Pump) System*.
- Günther, D.; Miara, M.; Langner, R.; Helmling, S.; Wapler, J. (2014). "WP Monitor" Field measurement of heat pump systems, Fraunhofer ISE, 15 July 2014 (in Germany).
- Haga, Y., & Nobe, T. (2007). Accuracy Verification of Thermal Flux Sampler for Onsite Performance Evaluation of VRV System. In *Proceedings of Clima 2007 WellBeing Indoors*. Helsinki, Finland.
- Ichikawa, T.; Yoshida, S.; Nobe, T.; Kametani, S. (2008). Running Performance of Split-type Air Conditioning Systems Installed in School and Office Buildings in Tokyo, *Refrig. Air Cond.* (2008) 1–8.
- IEA - International Energy Agency (2014). *Heat Pump Programme, Annex 36 Quality Installation / Quality Maintenance Sensitivity Analysis, Final Report*.
- IEA - International Energy Agency (2016). *Technology Collaboration Programme on Heat Pumping Technologies (HPT TCP), Annex 37 Demonstration of Field Measurements of Heat Pump Systems in Buildings, Good Examples with Modern Technology, Final Report*.
- IEA - International Energy Agency (2019). *The future of cooling: Opportunities for energy-efficient air conditioning*.
- IEA - International Energy Agency Technology (2020a). *Collaboration Programme on Heat Pumping Technologies (HPT TCP), Annex 49 Design and Integration of heat pumps for nearly Zero Energy Buildings, Final Report*.
- IEA - International Energy Agency Technology (2020b). *Collaboration Programme on Heat Pumping Technologies (HPT TCP), Annex 49 Field monitoring in nZEB with heat pump, Final Report Part2*.
- IEA - International Energy Agency (2021a). *Technology Collaboration Programme on Heat Pumping Technologies (HPT TCP), Annex 52, Guidelines for Instrumentation and Data*.
- IEA - International Energy Agency (2012). *Technology Collaboration Programme on Heat Pumping Technologies (HPT TCP), Annex 52, Guidelines for Calculation of Uncertainties*.
- IEA - International Energy Agency Technology (2022a). *Collaboration Programme on Heat Pumping Technologies (HPT TCP), Annex 52 Long-term performance monitoring of GSHP systems for commercial, institutional, and multi-family buildings*.
- IEA - International Energy Agency Technology (2022b). *Collaboration Programme on Heat Pumping Technologies (HPT TCP), Annex 52, Subtask 3 Report, Guide for analysis and reporting of GSHP system performance – system boundaries and key performance indicators (KPI)*.
- Jactard, A.; Li, Z. (2011). Investigation of field methods for evaluation of air-to-air heat pump performance, Master's Thesis, Sustainable Energy Systems programme, Department of Energy and Environment, Division of Building Services Engineering, Chalmers University of Technology, 102 pages.
- JRAIA - Japan Refrigeration and Air Conditioning Association (2023). *Annual Report, 2023*. Available: https://www.jraia.or.jp/statistic/2306_aircon.pdf.
- Kim, W., & Braun, J.E. (2016). Development and evaluation of virtual refrigerant mass flow sensors for fault detection and diagnostics. *International Journal of Refrigeration*, 63, 184–198.
- Matsui, E.; Kametani, S. (2020). Development of On-Site Performance Evaluation System for Multi-Air Conditioning Units in Buildings, *Journal of Air Conditioning, Heating, and Sanitary Engineering*, Vol.45 No.282, pp.19-26, 2020.
- Matsui, E.; Kametani, S.; Nobe, T. (2016). Accuracy Improvement of Performance Evaluation for Variable Refrigerant Flow Systems, *Proceedings of ECOS*, p424-432, 2016.
- Miara, M., & Kramer, T. (2011). *Heat Pump Efficiency Analysis and Evaluation of Heat Pump Efficiency in Real-life Conditions Abbreviated Version*.
- Naruhiro, S., & Shigeki, K. (2012). Study on the Development of the Performance Evaluation of VRF System Using the Volumetric Efficiency of the Compressor: Expansion of the Range of Application and Improvement of the Accuracy. In *Proceedings of the Society of Heating, Air-Conditioning and Sanitary Engineers of Japan (SHASE)*.
- Natural Resources Canada. (2022). *Technical Guideline for Field Monitoring*.
- Nobe, T.; Haga, Y.; Nakamura, H.; Nobe, T.; Haga, Y.; Nakamura, H.; Tanaka, K.; Kiguchi, M. (2011). Probe insertion method for on-site evaluation of VRF system, *Journal of Environmental Engineering (Transactions of AIJ)*. 76. 927-933. 10.3130/aije.76.927.
- Nordman, R.; Kleefkens, O.; Riviere, P.; Nowak, T.; Zottl, A.; Arzano-Daurelle, C.; Lehmann, A.; Polyzou, O.; Karytsas, K.; Riederer, P.; Miara, M.; Lindahl, M.; Andersson, K.; Olsson, M. (2012). *Seasonal Performance Factor and Monitoring for Heat Pump Systems in the Building Sector (SEPOMO-Build), Final Report*.
- NORDTEST (1997a). *NT VVS 115 - Refrigeration and heat pump equipment: General conditions of field testing and presentation of performance*, Finland, 19 pages.

- NORDTEST (1997b). NT VVS 116 - Refrigerator and heat pump equipment: Check-ups and performance data inferred from measurements under field conditions In the refrigerant system, Finland, 13 pages.
- Prinzling, M.; Berthold, M.; Eschmann, M.; Bertsch, S. (2020). Field measurements from heat pump systems, Heating season 2019/2020, 30 September 2020, Swiss Federal Office of Energy (in Germany).
- Riviere, P.; Nordman, R.; Tran, C-T.; Coevoet, M.; Zottl, A. (2011). Guidelines for heat pump field measurements on air-to-air heat pumps, SEPEMO project report.
- Shimizu, S.; Haga, Y.; Yumoto, Y.; Kametani, S.; Nobe, T. (2006). Actual performance evaluation system of package air-conditioner by sampling system of heat rejection flux from outdoor unit, Part2: Accuracy verification of sampling system of heat rejection flux from outdoor unit in the calorimeter box, Tech. Pap. Annu. Meet. Soc. Heat. Air-Conditioning Sanit. Eng. Japan. (2006) (in Japanese).
- Shimizu, S., Haga, Y., & Nobe, T. (2007). On-site Evaluation Method of Multi Split Air Conditioner System, Part 2: Investigation of Actual Efficiency by Sampling System. *Journal of Asian Architecture and Building Engineering*, 6(2), 341-347.
- Takahashi, S., Kametani, S., Itou, M., & Funatani, A. (2008). Study on Performance Evaluation Method of a Split Air Conditioning System Based on Characteristic Curve of the Compressor Mass Flow Rate. In *Proceedings of the International Refrigeration and Air Conditioning Conference*. Purdue University, West Lafayette, IN, USA.
- Teodorese, V., Detroux, L., & Lebrun, J. (2007). Testing of a Room Air Conditioner: High Class RAC Test Results - Medium Class RAC Test Results. University of Liege, Belgium.
- Tran, C.T., Rivière, P., Marchio, D., & Arzano-Daurelle, C. (2012). Refrigerant-based measurement method of heat pump seasonal performances. *International Journal of Refrigeration*, 35(6), 1583–1594.
- Ueno, T.; Yamazaki, Y.; Yoshida, S.; Sato, K.; Sawachi, T. (2022). Estimation for Energy Saving Effect of Chilled Water Temperature Relaxation in an Office Building with Multiple Heat Sources, *Journal of Environmental Engineering, Architectural Institute of Japan*, Vol. 87, No.802, December 2022 (in Japanese).
- Ueno, T. (2022). BEMS Data Analysis of Heat Source Facilities in Japan, A presentation in the Second Workshop for IEA EBC Annex 88, 9th March 2022.
- Won, A.; Ichikawa, T.; Yoshida, S.; Sadohara, S. (2009). Study on running performance of a split-type air conditioning system installed in the national university campus in Japan, *J. Asian Archit. Build. Eng.* 8 (2009) 579–583.
- Xiao, H., Shi, J., Yang, Z., Wang, B., Shi, W., & Li, M. (2022). Precision improvement method for onsite performance measurement of variable refrigerant flow system. *Building and Environment*, 2022, 108626, ISSN 0360-1323, <https://doi.org/10.1016/j.buildenv.2021.108626>.
- Yang, Z., Ding, L., Xiao, H., Zhang, G., Wang, B., & Shi, W. (2020). All-condition measuring methods for field performance of room air conditioner. *Applied Thermal Engineering*, 180, 115887.
- Zhang, G., Liu, W., Xiao, H., Shi, W., Wang, B., & Li, X. (2019). New method for measuring field performance of variable refrigerant flow systems based on compressor set energy conservation. *Applied Thermal Engineering*, 154, 530–539.
- Zhang, G. (2020). Research on the measurement method for the cooling and heating capacity of the multi-split air-conditioner and its running performance in office buildings, Tsinghua University, (in Chinese).
- Zhao, W. (2009). Study on Part Load Performance of Variable Refrigerant Flow System. Tsinghua University, Master's Thesis, Beijing, China.
- Zottl, A.; Nordman, R.; Coevoet, M.; Riviere, P.; Miara, M.; Benou, A.; Riederer, P.; Andersson, K.; Lindahl, M. (2011). Guidelines for heat pump field measurements for hydronic heating systems, SEPEMO project report.

3. State of the art for energy use calculation methods for heat pump systems

3.1 Introduction (context of energy performance calculation methods and standards)

3.1.1 Context/Background

The need for energy performance calculation of heat pumps is a consequence of the evolution of legal requirements and available technologies concerning the energy performance of buildings. A similar trajectory can be observed in most advanced countries in the world.

Taking Europe as an example, before the first oil price shock in the years 1970s, there were no or little regulations about the energy performance of buildings. The first oil shock in 1973 triggered a wave of regulations that focused on heating and on limiting the installed heating capacity. The supporting standard was the heat load calculation, which is still used for basic sizing purpose (EN 12831 (CEN, 2017b)).

Besides the cost, the concern about resource depletion triggered attention on the energy performance. The next step around the years 1980s to 1990s were regulations limiting the energy need for heating, involving only the building envelope. The requirement applied to new buildings and the supporting standard was EN 832. The calculation of building envelope energy need for heating and cooling was soon standardised at the highest level (ISO) and EN 832 evolved as EN ISO 13790 and now EN ISO 52016-1:2017 (CEN, 2017a).

In the next decade (years 90s) technical systems were included in the energy performance calculation, starting with heating and domestic hot water systems. This was considered by local (national or regional) standards. Since technical systems may use several energy carriers, the concept of weighted energy was introduced. Initially, non-renewable primary energy was used as a reference, sometimes implicitly just to compare fossil fuels and electricity.

Then, the concern about energy performance was extended to include all comfort services (cooling, ventilation, dehumidification, lighting) and ultimately, following installations of PV panels, also exported energy had to be considered somehow. The extension to other services is justified because heating needs can be dramatically reduced by building envelope insulation whilst the other comfort services are little or not at all influenced by the building envelope properties (e.g. domestic hot water).

Now the new objective of decarbonisation implies that fossil fuel energy carriers be dismissed. Unless synthetic fuels are produced in significant amounts from non-fossil and carbon free sources, electricity will be the fundamental energy carrier to supply energy to buildings and the nearly obliged choice for space heating and cooling and domestic hot water preparation is heat pumping. Direct electric heating is inefficient compared to heat pumping and should be limited to small and localised loads.

Energy performance calculation methods are a fundamental supporting tool because any regulation that sets energy performance requirements needs a “meter”, so that buildings can be evaluated and compared to the requirements, whichever the purpose. As shown in Figure 3.1.1-1, the meter is the calculation method that provides the energy performance of the building to be compared with the regulated value.

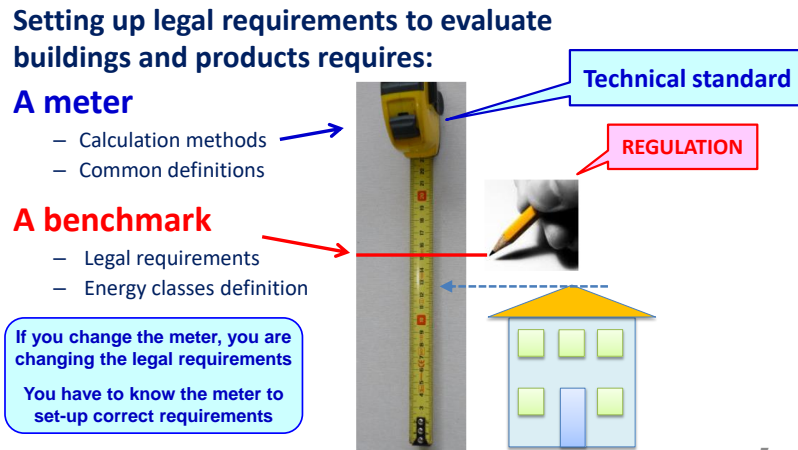

7

Figure 3.1.1-1. The complementary role of regulations and calculation methods (technical standards)

The calculation method may also provide performance indicators for specific parts of the building (sometimes called “partial performance indicators”) to support the regulation of renovation work and/or to complement the overall energy performance requirement of the building to avoid efficiency trade-off between different parts. Examples of partial performance indicators are the energy need of the building envelope and the seasonal performance factor of a heat pump, which may be both regulated to avoid trade-off between envelope insulation and heating system efficiencies.

The calculation method can be detailed directly in the regulation, or the regulation may refer to technical standards, such as national or international standards (EN and ISO). The calculation method shall be stable because any change in the calculation method causes implicitly a change in the requirement, if requirements are not updated accordingly.

The calculation of the energy performance to demonstrate compliance and get a building permit is a common practice in most EU countries since years 1990s.

The first EPBD (energy performance of buildings) Directive 2002-91-CE established the obligation for all EU member states to:

- establish a calculation method of the energy performance of buildings;
- set minimum energy performance requirements for new buildings;
- require an energy performance certificate stating the amount of energy required to provide a standardised comfort level with standard climatic conditions and building use so that the building's energy performance becomes a factor in the real estate market when selling or renting.

The intent of the Energy Performance Certificate is to display the energy performance of the building when selling and renting so that it is part of the economic evaluation of the building. This mechanism makes the energy efficiency not only a regulatory requirement but also a market opportunity (higher value of the building).

The EPBD Directive left Member States with the freedom to choose their own calculation methods, provided they considered a list of influencing factors. This is because several EU countries already had their own methods in place for several years and the market of buildings is local. Unlike products, building do not travel across national boundaries and also building professionals usually operate on a local scale. So, there was not a strong feeling for a need of a unique European calculation and evaluation method. The argument of “national specific conditions” was always used to delay uniform EU calculation methods. It must be noted that energy performance calculation methods concerning the building envelope are almost uniform across Europe: EN 832 (and then EN ISO 13790 and now EN ISO 52016-1) (CEN, 2017a) are used everywhere. A variety of methods flourished especially for technical systems and for the final energy weighting, leading to quite different indicators (in terms of both quality and quantity) across EU countries. This variety of methods is even more evident for new technologies like heat pumps.

EPBD Directive evolved. The first recast (a new version is issued, the old is cancelled) of directive 2010/31/UE, introduced the concept of NZEB (nearly zero energy buildings) which was set as the target for new buildings.

In 2018, the EPBD was amended and the concern for the variety of calculation methodologies was first addressed. The EU Commission could not impose a common method, but each member state had to compare its calculation method with a set of so-called “overarching” EN standards.

A further recast of the EPBD directive has been approved in May 2024 and it will change the target to “zero emission buildings”, coherently with the general decarbonisation objective. The decarbonisation has huge impacts at a global scale but also on the individual building scale. The currently available energy carriers are listed in Table 3.1.1-1.

Table 3.1.1-1. Energy carriers and decarbonisation.

Energy carrier	Notes
Natural gas	To be dismissed
Oil	To be dismissed
LPG	To be dismissed
Electricity	No emission where used. Should be produced with renewable and carbon free sources. Available in every building
Biofuels	Available in a limited quantity. Biofuels require large plants for their production
Hydrogen and synthetic fuels	Should be produced with renewable and carbon free sources

The consequence of the decarbonisation is that the first three carriers must be dismissed. In several EU member states, natural gas and fossil fuels are already banned from new buildings and the EPBD recast is encouraging fossil fuels dismissal in the whole EU. On the long run, this means that fossil fuel boilers will be phased out and cannot be used any more.

Biofuels can be available only in limited quantities. Hydrogen and synthetic fuels are still experimental. So, it is expected that in the short term, the heat pump will become the main heat generator for new buildings and, on medium term, it will be the main generator for existing buildings as well.

In several EU countries, there are already requirements that oblige to install heat pumps in new buildings with few exceptions (biofuel boilers, efficient district heating).

The urgent need for reliable heat pump energy performance calculation methods is therefore obvious.

3.1.2 Challenges

3.1.2.1 General challenges for energy performance calculation methods

To support regulations, the energy performance calculation methods should be:

- reasonably accurate;
- comprehensive, i.e. covering all relevant applicable technologies;
- applicable, that is based on available building and product data;
- understandable by practitioners;
- objective;
- software proof.

The overall accuracy is hard to evaluate because of the huge number of input data and of the uncertainty on each one of them. As an order of magnitude, an uncertainty up to 10% is expected or desired. The

evaluation of accuracy is hard because in most cases there is no “real value” or “experimental value” to compare, due to the random influence of climate and use of the building. The evaluation is often done by comparing with other models that are assumed to be more accurate.

Comprehensiveness is required because since the calculation method is the tool to fulfil legal requirements (e.g. to get a building permit or a permit of use), failing to cover a technology means that this technology is de facto not allowed or its contribution will not be recognised for regulatory purpose. This is relevant, especially for technical systems, that may have several variants.

Applicability is an issue especially for technical systems, where the choice of the calculation model imposes the required input data. A coordination is needed between developers of building energy performance calculation methods and developers of product testing procedures. This is rarely the case with technical systems. Heat pumps are precisely an example of this issue.

Energy performance calculations are performed using software. Practitioners shall still be able to understand the methods so that they are aware of what is calculated by the software. They are held responsible for the result of the calculation that determines an authorisation from public authorities, so they must be in control of the calculation process. Calculation methods shall be objective, i.e. unbiased. If not, the comparison between alternative solutions would be incorrect and unfair.

Being software proof is an emerging requirement for calculation methods. Calculating the building energy performance implies several calculations, which are not feasible in the daily routine of professionals without the help of a computer. An Excel file can be enough only for very simple buildings and monthly methods, for research or software validation purpose. Complex buildings and hourly methods require the use of software. Developing the software based on standards requires that the method is fully unambiguous and that the chain of equations is complete.

All software models have inherent limitations. It is important that users understand the limitations of inputs and applications, so that they can ensure the answers are reasonable; unfortunately, it is too common that users simply trust complex simulation software to be “correct” and often make fundamental errors in the software’s use. Having full insight into the calculation method and being able to experiment would enable users to get a better feeling of capabilities, limitations, input requirements and sensitivity of the method. Additionally, tools should be developed to help validate both software processes and individual software results, providing cross-checks on basic parameters

All these requirements must be balanced when designing calculation methods.

To tackle some of these challenges, in the CEN environment, those responsible for drafting calculation methods are required to provide an Excel file for demonstration, verification, validation, quality assurance and education purposes.

3.1.2.2 Specific challenges on heat pumps energy performance calculation

The modelling of heat pumps, which are expected to become the main generation technology to provide space heating, raises several specific challenges.

- The performance of the heat pump is extremely sensitive to operating conditions and the efficiency spread is at least 1 to 3 in the expected operating range (whilst it is $\pm 10\text{...}15\%$ for boilers).
- There are several types of heat pumps, depending on source and sink types (air, water, etc.), basic technology (vapor compression, absorption, etc.), which implies a variety of calculation options to achieve comprehensiveness.
- There are multiple internal control options (compressor speed, fan speed, etc.) and external control options (cut-off temperatures, priorities, etc.) that can significantly impact heat pump performance.
- The availability of standardized product data is limited and not finalized to energy performance calculation.
- Operating conditions are related to other parts of the calculation. The connection may imply iterations or approximations (e.g. exhaust air pump performance depends on temperature and flow rate of available exhaust stream).
- Products which are providing simultaneous heating and cooling are appearing on the market, which requires to integrate the calculation methods for the heating and cooling functions.

The increasing role of automation and controls, not to mention AI, is providing another layer of complexity. The compromise between simplicity versus accuracy is therefore hard to achieve for heat pumps.

3.1.2.3 Expected outcome of a “heat pump module”

The heat pump calculation is just a “module” within (a section of) the overall building energy performance calculation. Like any generation sub-system module, its objective is to answer the following three questions for each calculation interval (month, hour or bin):

- can the heat pump provide the heat supply (or heat extraction) required by the attached systems?
- what are the required inputs?
- are there secondary outputs (e.g. recoverable heat)?

In other words, given:

- the duration (hours) of the calculation interval;
- the required energy output (kWh) for each service (heating, cooling, domestic hot water);
- the required operating conditions for each service (e.g. leaving water temperature, room air temperature);
- the product data (hp properties and performance map);
- the system control options;

the heat pump module must calculate:

- the part of the required energy output that can be provided by the heat pump and/or the integrated back-up heater;
- the required driving energy;
- the required auxiliary energy;
- the recoverable heat, if any, is available and considered.

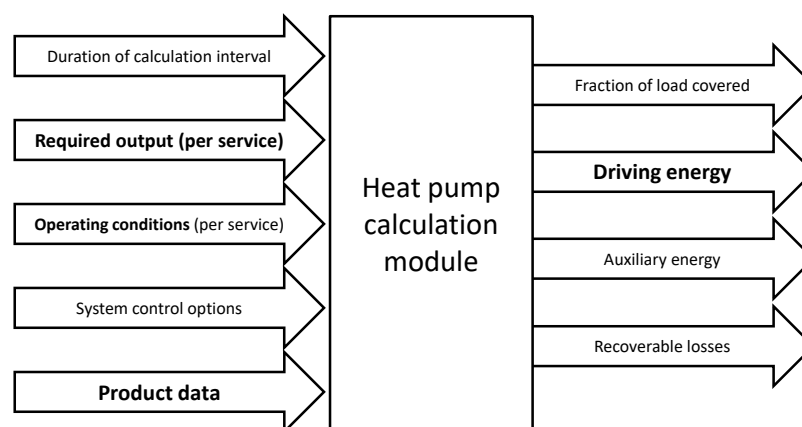

Figure 3.1.2-1. Inputs and outputs of a generic heat pump calculation module. The font size highlights the relative importance of input and output data

The duration of the calculation interval does not matter, unless the time interval is much shorter than 1 hour. One hour is already much longer than the expected transients of heat pump operation. Therefore, no dynamics is expected in a heat pump hourly calculation module. Figure 3.1.2-1 shows some inputs and outputs of a typical heat pump calculation module⁴.

⁴ The most common calculation interval in the European countries is still monthly. There is a progressive shift to hourly calculation method (due to the necessity to handle increasing automation, intermittent operation, and interaction with the grid). The most likely next step might be a 15 minutes calculation interval, to align with the electric grid metering based on 15 minutes sampling. Even for this option, the internal dynamics to the heat pump is much faster and likely to be neglected.

3.2 Heat pump energy performance basics

3.2.1 Definition of energy performance indicators and common parameters

3.2.1.1 Energy performance indicators

The heat pump is a machine that forces the transfer of heat:

- from a cold medium (the “source”) at a lower temperature;
- to a hot medium (the sink) at a higher temperature.

The driving energy adds to the transferred heat on the sink side.

The efficiency of any machine is defined as the ration of a useful effect to the resource needed to get it.

For any heat pump in heating mode:

- the useful effect is the heat output to the sink;
- the resource used is the amount of driving and auxiliary energy that is needed to run the heat pump.

This ration is usually called COP (coefficient of performance). The energy captured from the external environment (from outdoor air, water, or ground) is not included, because it costs nothing.

For any heat pump in cooling mode:

- the useful effect is the heat extracted from the source;
- the resource used is the amount of driving and auxiliary energy that is needed to run the heat pump.

This ration is called EER (energy efficiency ratio).

NOTE 1 depending on the context, COP may be used for both heating and cooling, whilst EER is reserved for cooling.

NOTE 2 In the US, which uses primarily IP units, COP and EER refer to a different convention of measurement units. COP is expressed as a ratio of like units (thus is the same as in SI units) whilst EER is expressed as Btu/(W·h) so it is on a different scale: EER in SI units = EER in IP units x 3,412.

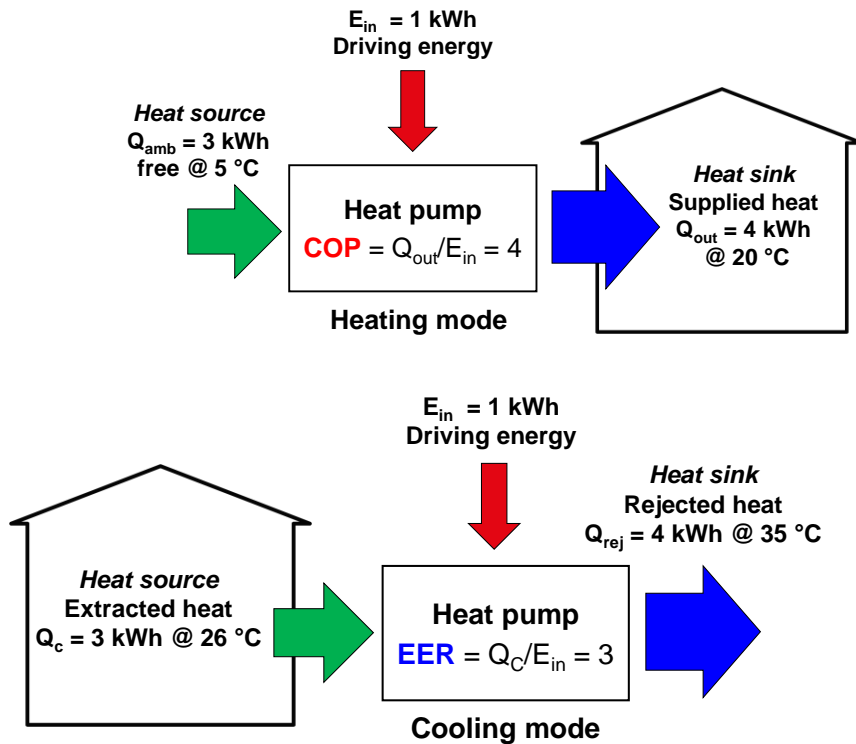

Figure 3.2.1-1. The basic definition of COP and EER

The basic definition of COP and EER is straightforward, but there are several possible variants depending on the considered time-span and scope of COP and/or EER evaluation (see Figure 3.2.1-1).

The instantaneous value of COP or EER is a ration of instantaneous power in a given operating condition whilst the average value of COP or EER in a time span (hour, month, bin, season, ...) is a ration of cumulated energies over a defined calculation period.

$$\text{instantaneous COP} = \frac{\Phi_{out}}{\Phi_{in}} \quad \text{instantaneous EER} = \frac{\Phi_c}{\Phi_{in}} \quad (3.2.1.1)$$

$$\text{average or seasonal COP} = \frac{\sum_i Q_{out,i}}{\sum_i Q_{in,i}} \quad \text{average or seasonal EER} = \frac{\sum_i Q_{c,i}}{\sum_i Q_{in,i}} \quad (3.2.1.2)$$

COP and EER can be based on either calculated or measured data.

Concerning the scope, in principle it can be the entire “heat pump” device, but it can be restricted to the compressor or enlarged to include auxiliary devices such as the integrated back-up heater, the heat source or heat rejection auxiliaries.

Concerning the services provided, the scope can be heating, domestic hot water, cooling, or a combination thereof.

Figure 3.2.1-2 provides an example of different possible scopes according to the part of the installation which is being evaluated:

- HP is the heat pump scope that considers only the driving energy W_{hp} (electricity to the compressor) and internal auxiliaries $W_{aux,int}$ (e.g. evaporator and condenser fans of an air to air heat pump);
- whilst GEN is the “generation scope” that includes external auxiliaries $W_{aux,ext}$ (e.g. circulation pumps) and back-up heater input W_{bu} .

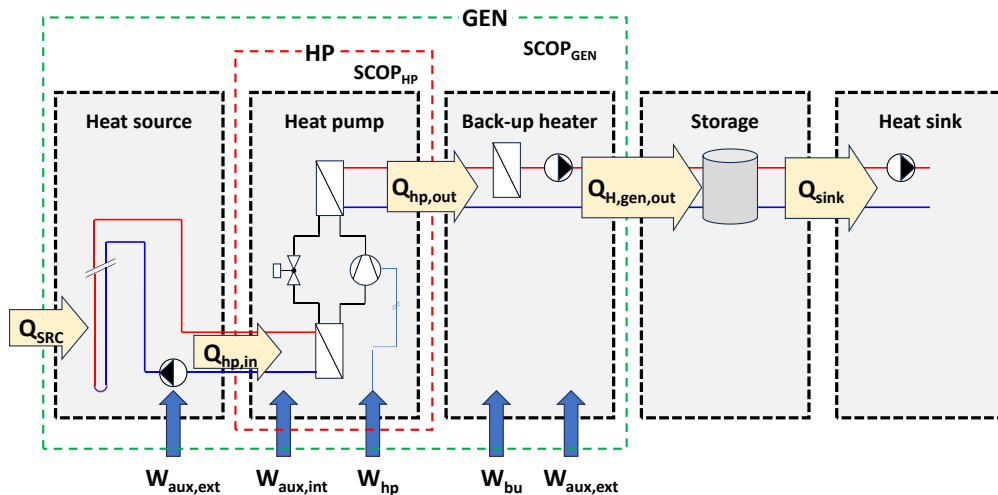

Figure 3.2.1-2. Example of possible scopes of COP and EER

When reporting a COP or EER value, all the boundary conditions must be clearly stated.

- A mere statement such as “the COP of the hp is 3,0...” means nothing.
- A complete statement should be (for example) “the calculated seasonal COP of the heat pump for the heating service, including all auxiliaries, is X ...”. For a seasonal COP, the climate assumptions must also be clearly specified.
- When reporting instantaneous COPs and EERs, a code can be added to indicate the type and temperature of source and sink, like A7W35. Unfortunately, this coding does not indicate the applicable part load, which is also significantly influencing the instantaneous efficiency of a heat pump.

In general, the quality of the reference to boundary conditions in the technical documentation of products is poor, e.g. relying on notes specifying the applicable operating temperatures and load for the specified efficiencies.

Building energy performance calculation methods shall provide seasonal values of the COP and EER according to the GEN boundary of Figure 3.2.1-2, based on product data which are instantaneous data related to HP boundary.

3.2.1.2 Common parameters (product data)

The properties of the heat pump are defined by a series of parameters, such as:

- maximum capacity and part load range;
- temperature limitations for both source and sink (operating range);
- declared efficiencies in a set of operating conditions, which are often stated as declared capacities and input power across those conditions.

The maximum capacity of the heat pump is relevant for sizing and to assess if it can provide the required services in the calculation interval. The maximum capacity may depend on:

- evaporation temperature;
- maximum driving power (control limitation for inverter type heat pumps);
- condensation temperature.

The maximum capacity is not well defined in the EN standards. EN 14511 (BSI, 2018) only defines a “nominal capacity” which is stated by the manufacturer. Even though this is mostly interpreted as nominal capacity = maximum capacity, this is not always the case.

The part load range (or the minimum output power with continuous operation) is seldom declared by the manufacturer. This information is important because:

- on off cycling has detrimental effects on both efficiency and life span of heat pumps;
- turndown ratio is limited (1:2 to 1:3) compared to other generators, like e.g. boilers that easily reach 1:5;

- oversizing and the increase of maximum power at the extreme outdoor temperature for AA and AW heat pumps brings to frequent on-off cycling.

The operating range of the heat pump applies to assess if it can provide the required services. Example of such limitations are:

- minimum source temperature may be critical in cold climates (no heating available in the coldest days);
- maximum sink temperature may be critical based on the design of the indoor distribution system, or to provide domestic hot water service. Thermal cycles for legionella prevention may require a back-up heater;
- maximum source temperature may be critical (depending e.g. on refrigerant used) for domestic hot water service in temperate and warm climates (e.g. no domestic hot water is available if outdoor temperature exceeds the maximum operating temperature of the condenser).

Efficiency (COP) depends strongly on influence factors (see next clause). Any declared efficiency value shall be accompanied by operating conditions information such as source temperature, sink temperature and load factor.

Conventionally efficiencies are reported with tags like “A7W35” that specify the type and temperature of source and sink. However, this convention lacks an indication about the load factor at which the COP was measured. A tagging like A7W35P100 could incorporate the information that the declared COP is for full load (provided there is a clear definition on “full load”- see next clauses).

3.2.2 Influence factors

3.2.2.1 Introduction

Calculating the energy performance of a heat pump means considering the effect of significant influence factors, like:

- source and sink temperatures;
- part load operation;
- system control options;
- auxiliary energy use;
- defrosting.

3.2.2.2 Source and sink temperatures

The sensitivity to source and sink temperature is in the range of 2 to 3% per °C temperature change.

The source from which to extract heat for heating or to which to reject heat for cooling may be:

- external air;
- exhaust air;
- internal air;
- ground;
- ground water;
- surface water;
- special devices like solar collectors.

Source and sink temperature is a data input coming from:

- climatic and environmental data, for outdoor air, groundwater, surface water, that cannot be controlled;
- results of other parts of the calculation for ground coupled heat exchangers, exhaust air, indoor air, that can be controlled only to some extents by system sizing and operation mode;
- results of other parts of the calculation for required leaving water temperature that can be controlled by system sizing and operation mode.

3.2.2.3 Part load

Since part load is defined as the ratio of actual load to full load, before defining part load, full load must be defined. For heat pumps, full load capacity is a moving target (because it depends on evaporation

temperature and maximum driving power) and a clear definition of full load is not yet available in the EN and ISO standards. It is sometimes assumed that “nominal load” is “full load” but for several products, there are different values for “maximum load” and “full load” at different operating conditions.

“Full load” should be the maximum heat power output under given operating conditions (source and sink temperature). The first issue is that full load capacity depends mainly on the evaporation temperature (hence on the cold source temperature) and somehow also on the condensation temperature (sink temperature). A possible definition of part load is the ratio of actual required capacity (actual load) to the maximum capacity at the same operating conditions (CR, capacity ratio).

Instead of using a moving target, EN 14825 (BSI, 2022) defines part load as the ratio of actual load to a fixed power P_{des} (“design power”) which is just a reference power to set test conditions, adding to the uncertainty.

The second issue is that the full load capacity may be limited by internal controls of the heat pump to avoid compressor and power supply overload or to improve efficiency. In this case, it is important to understand that limiting the maximum capacity by controls has implications on the turndown ratio.

Additionally, part load operation can be:

- either continuous operation at reduced power (e.g. reduced compressor drive frequency);
- or intermittent operation (on-off cycling) at a given minimum power.

These two modes require different calculation procedures.

The impact of part load operation on efficiency is because of several causes:

- compressor performance decay at lower loads;
- energy lost for each start-up of the compressor during cycling;
- change in temperature drop across evaporator and condenser heat exchangers, as detailed in the next clause.

When modulating (inverter technology), the change in temperature drop across heat exchangers may have a positive effect (may, because this effect depends on the control strategy of the fan, see next clause), so that part load operation may be initially beneficial until compressor efficiency decays and intermittency losses prevail and COP eventually drops at low loads. Given that most of the time heat pumps work at part load, this is challenging to consider correctly.

Intermittent operation is characterised by at least two parameters:

- duty cycle, that is the fraction of time with compressor ON. The output power is mostly determined by this parameter;
- cycling frequency, that is how often the compressor starts and stops. The decay in COP looks mostly related to this parameter.

Figure 3.2.2-1 illustrates these concepts.

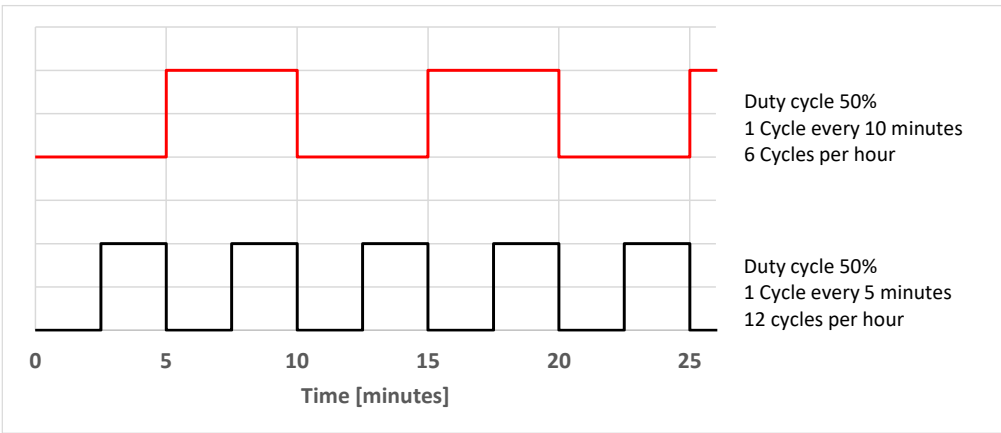

Figure 3.2.2-1. Example of different cycling frequency with the same duty cycle

Both operating modes shown are characterised by a 50% duty cycle, meaning that the average power is approximately 50 % of the power when ON in both cases. However, the operating condition with a higher

frequency of start stops (i.e. a shorter cycle time) is less efficient (because each start stop causes e.g. depressurisation of circuits) and causes compressor wear (poor lubrication during compressor start).

The cycling frequency is determined by several factors such as:

- available volume of water for the heat pump and flow rate in hydronics systems;
- volume and geometry of the conditioned room for air-based system;
- control settings of both heat pump and installation.

which make the evaluation difficult since they depend highly on building and systems design choices.

3.2.2.4 Temperature difference of external fluids across evaporator and condenser

An additional hidden challenge is the fact that, for practical purpose, operating conditions are defined according to the available and accessible source and sink temperatures, like:

- external air (or ground loop) temperature as source temperature for heating mode and sink temperature for cooling mode;
- room air or leaving water temperature as sink temperature for heating mode and source temperature for cooling mode.

However, the relevant temperatures that define the operating conditions of the thermodynamic compression cycle are the evaporation (source side) and condensation (sink side) temperatures.

This is shown in Figure 3.2.2-2.

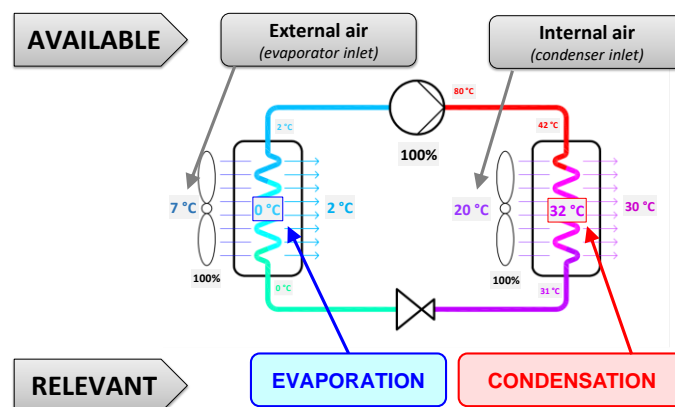

Figure 3.2.2-2. Example of the relationship between available temperatures and relevant temperatures for an air to air heat pump in heating mode

There are two main possible contributions to the difference between available and relevant temperatures.

- The temperature difference between inlet and outlet of the external fluid across the evaporator and the condenser.

Figure 3.2.2-2 shows that external air is entering the evaporator at 7 °C (the available information) but it leaves the evaporator at 2°C. To allow capture of heat with a reasonable flow rate, a temperature difference of 5°C is required.

Similarly, indoor air is entering the condenser at 20 °C (the available information) but it leaves the condenser at 30°C. To allow release of heat with a reasonable flow rate, a temperature difference of 10°C is required on this side (typically higher than on the external side for comfort reasons).

- Any heat exchanger has an approach, that is a residual temperature difference between the fluids that are exchanging heat. In Figure 3.2.2-2, the evaporation temperature shall be 2°C below evaporator

outlet temperature to capture heat from external air and condensation temperature shall be 2 °C higher than condenser outlet to allow heating indoor air to 30 °C⁵.

This is a huge impact, especially for air-to-air heat pumps. Taking as an example the operating conditions shown in Figure 3.2.2-2:

- The maximum theoretical COP in transferring heat from an environment at $\theta_C=7^\circ\text{C}$ (source) to another at $\theta_H=20^\circ\text{C}$ (sink temperature) COP_{Carnot,src_snk} is 22,5, as shown in equation (3.2.2.1).

$$COP_{Carnot,src_snk} = \frac{\theta_H + 273,15}{\theta_H - \theta_C} = \frac{20 + 273,15}{20 - 7} = 22,5 \quad (3.2.2.1)$$

- The practical maximum theoretical COP ($COP_{Carnot,max}$) due to the temperature differences on the heat exchangers is only 9,5 because the compressor must transfer heat from the evaporation temperature $\theta_{evap} = 0^\circ\text{C}$ to the condensation temperature $\theta_{cond} = 32^\circ\text{C}$, as shown in equation (3.2.2.2).

$$COP_{Carnot,max} = \frac{\theta_{cond} + 273,15}{\theta_{cond} - \theta_{evap}} = \frac{32 + 273,15}{32 - 0} = 9,5 \quad (3.2.2.2)$$

- Since the current technology achieves approximately 45 % of the Carnot COP (this is the “exergetic efficiency” η_{exe} , that is the ratio of the actual COP to the corresponding theoretical Carnot COP), the expected COP according to evaporation and condensation temperatures is 4,3 and not 10,1 as expected according to source and sink temperature. This is shown in equations (3.2.2.3) and (3.2.2.4).

- Expected COP according to source and sink temperature $COP_{exp;src_snk}$:

$$COP_{exp,src_snk} = COP_{Carnot,src_snk} \cdot \eta_{exe} = 22,5 \times 0,45 = 10,1 \quad (3.2.2.3)$$

- Expected COP according to evaporation and condensation temperature COP_{exp} :

$$COP_{exp} = COP_{Carnot,max} \cdot \eta_{exe} = 9,5 \times 0,45 = 4,3 \quad (3.2.2.4)$$

The impact of the temperature difference across evaporator and condenser for this sample operating conditions is a 57% reduction of the COP, which is not negligible at all.

The magnitude and impact of the temperature differences across source and sink heat exchangers depends on:

- source and sink heat exchangers sizing;
- type of source and sink (for water sinks, the available temperature is already the outlet);
- required load;
- control strategy of the external fluid flow rate (e.g. evaporator and/or condenser fan speed control).

Considering the available temperatures instead of the relevant temperatures for the calculation therefore introduces a distortion which depends on the heat pump type. If this approximation is not acceptable, the calculation method may include algorithms to estimate evaporation and condensation temperatures, but this requires additional assumptions and data.

3.2.2.5 Control options

Despite its apparent simplicity, there are several control options of the heat pump system that significantly affect its performance.

Control options can be classified in several ways. One possible classification is according to the responsible for the set-up:

- user adjustable parameters that can be set by the end user;

⁵The “external fluids” are those fluids from which heat is captured or to which heat is rejected by the refrigerant. The refrigerant (where evaporation and condensation occur) is separated from the external fluids (where available temperatures are measured) by heat exchangers that introduce temperature differences.

In total, for the given operating conditions, the temperature difference between sink and source:

- appears to be 13 °C (20 – 7) if calculated according to available temperatures;
- but is actually 32 °C (32 – 0) if calculated according to relevant temperature.

- control options and parameters that can be specified and set by the professionals involved in the heat pump installation, commissioning, maintenance, and operation (designer, operation and maintenance (O&M) staff);
- control options that are embedded into the heat pump firmware and that are only accessible by the manufacturer.

Examples of user adjustable parameters are:

- the temperature set-point of a heat pump domestic hot water heater;
- the operation time schedule.

User adjustable parameters are linked to the level of service (comfort level). The calculation method may handle them for energy auditing purpose. For regulatory purpose a standardised level of service is assumed for a fair comparison.

Examples of control options that are set according to the specific design are:

- the outdoor temperature reset of leaving water temperature;
- the bivalent temperature, that is the temperature at which a back-up generator is started;
- the hysteresis of on-off controls;
- building automation functions.

These control options should be specified in the design and/or during commissioning and considered in the calculation.

Examples of embedded control options are:

- the modulation range of the inverter heat pump;
- the fan speed control of source and/or sink when air is the external fluid;
- the defrosting logics.

Most energy performance calculation methods of heat pumps make a considerable number of assumptions and several control options are not explicitly considered. It is therefore important that products are tested with representative settings of controls.

3.2.2.6 Auxiliaries

The driving energy is feeding the heat pumping process. For vapor compression heat pumps, the driving energy is usually the electricity to the electric motor of the compressor. The declared COP or EER of a heat pump always includes the driving energy.

Auxiliary energy, as opposed to the driving energy, is used for tasks that help the operation of the heat pump. The main purposes of auxiliary energy are:

- circulating the external fluids across the evaporator and condenser;
- powering controls;
- heating the crankcase to avoid liquid refrigerant in the compressor.

For the purpose of the connection of product data with the calculation methods, auxiliaries are classified in two categories:

- "internal auxiliaries", which are already included in the declared COP or EER and shall not be calculated again;
- "external auxiliaries", which are not included in the declare DOP and EER and therefore must be accounted for separately and added to get the COP within the "GEN" scope of Figure 3.2.2-2.

Example of internal auxiliaries are:

- the evaporator and/or condenser fan of an air coupled heat pump;
- control circuits.

Examples of external auxiliaries are:

- the lifting pump of a ground-water heat pump;
- the cooling tower of a water cooled chiller;
- the back-up heater energy.

A practical rule to identify internal and external auxiliaries is:

- Internal auxiliaries are under direct control of the manufacturer and are independent of the case specific installation. An example is the evaporator and/or condenser fan of an air coupled heat pump: it is part of the supplied machine and controlled by the manufacturer's firmware. The manufacturer is totally responsible for the sizing of these auxiliaries.
- External auxiliaries are not under control of the manufacturer, and they depend on installation specific conditions. An example is the lifting pump of a groundwater coupled heat pump. The manufacturer does not know where the heat pump will be installed and which is the required lifting height.

There are also cases where the auxiliary energy of a component is considered partly internal and partly external. A frequent example is the circulating pump incorporated into a heat pump. The pump is controlled by the heat pump automation, but in the product testing, only the energy allocated to the pressure loss within the condenser is counted into the testing. This makes sense because the attached hydraulic circuit is not under the control of the manufacturer that tests the product.

Auxiliary energy use may be quite relevant for ground coupled systems, systems using groundwater and for heat rejection of air-cooled chillers.

There are no standardised ways to define the power of external auxiliaries and to account for their varying power according to load.

3.2.3 Connection with the overall building energy performance calculation

Due to the high sensitivity of the heat pump efficiency on the operating temperatures, it is important that the other parts of the calculation provide an accurate estimation of the source and sink temperature. Sink temperature (required leaving water temperature from the heat pump) calculation for hydronic systems depends on:

- heating terminals properties and sizing compared to the required heat output;
- heating circuits control options
- distribution temperature control options
- allowed operation time
- ratio of flow rate in the distribution and generation circuits.

If this is not calculated accurately, the calculated COP of the heat pump will be affected.

3.3 Current methods

3.3.1 EN standards

3.3.1.1 EN standards

In Europe, in the context of CEN, a set of standards has been developed to cover the calculation of the energy performance of a whole building. These standards were drafted following two mandates (financing) provided by the EU commission to support the EPBD directive implementation. The first set of EN standards for energy performance of buildings was published in 2007 and it has been revised in 2017. This set of standards is known as "EN-EPB standards" and Figure 3.3.1-1 shows its overall organisation in modules.

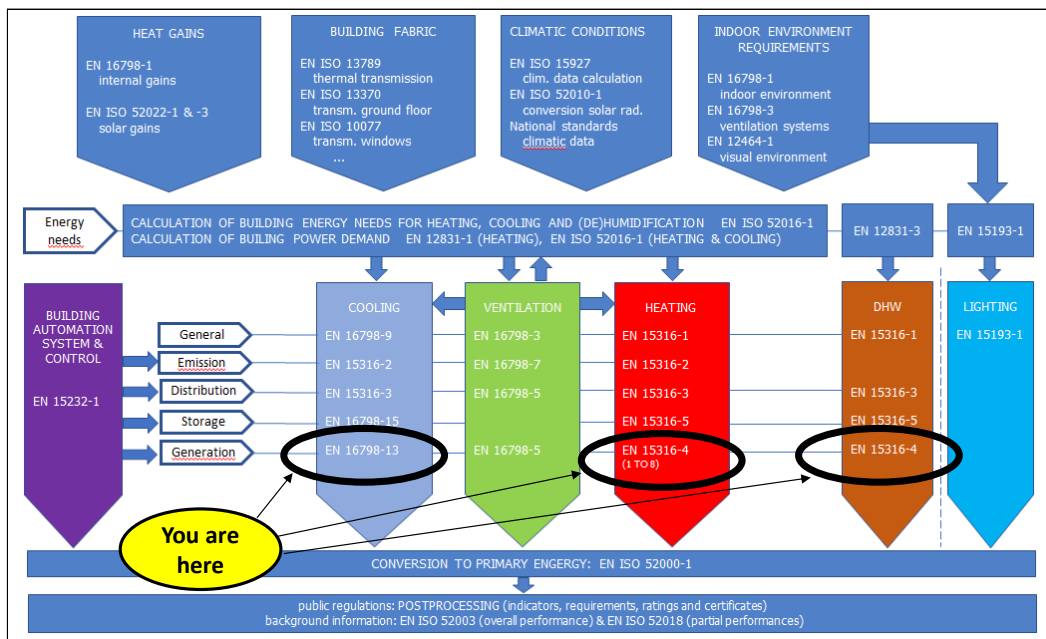

Figure 3.3.1-1. The structure of the set of EN-EPB. “You are here” balloon indicates the modules covering heat pumps for heating, cooling and domestic hot water)

Individual EN-EPB standards are developed to be a piece of the overall calculation. Therefore, their structure and formatting must comply with common technical and editorial rules given in the CEN Technical specification CEN-TS 16679:2014 (CEN, 2014) to ensure compatibility of modules and suitability for implementation by software developer (“software-proofness”). This includes common rules for:

- symbols, subscripts, and definitions;
- organisation of the text, with predefined clauses for output data and input data which must be listed and defined, including the source of input data and the intended destination of output data;
- explicating any option or choice by using “identifiers” to label them and avoid any ambiguity;
- supporting national customisation by providing a template for the required input data in normative annex A, whilst a default input data set is given in informative annex B to allow immediate use of the standard (but the default input data-set can be superseded by national application documents, since it is informative). In the ISO environment, this includes possible reference to supporting national standards;
- providing an XLS file, with a predefined structure (three sheets dedicated to input data, step-by-step calculation procedure, and output data respectively) to demonstrate and test the proposed calculation procedure;
- providing an accompanying technical report with all supporting information (informative contents).

EN 15316-4-2:2017 (CEN, 2017c) is the current module dedicated to heat pumps.

The whole package is not used “as is” in its entirety in any EU country, which is still free to have their own building energy performance calculation procedures for regulatory purpose.

Several EN-EPB standards, especially those concerning the building envelope like EN ISO 52016-1 (CEN, 2017a) (and related supporting standards) are in use in most EU countries. Some, like EN 15316-4-2 (CEN, 2017c) are not used as is but national experts participating in the EN committees introduce elements from the EN standards into their national calculation schemes.

A convergence process of EN and ISO standards in the field of energy performance of buildings is in progress since EN-EPB standards are being converted into EN ISO standards. Several EN-EPB standards, especially for the building envelope part and for heating and domestic hot water systems, are already EN ISO standards since they have been developed jointly under CEN lead. ISO already reserved a block of numbers (ISO 52000 series) to allow a complete coverage of the energy performance of buildings.

3.3.1.2 EN 15316-4-2: heating mode

3.3.1.2.1 Status

EN 15316-4-2 (CEN, 2017c) is the EN EPB module for the calculation of the efficiency of heat pumps in heating. The first release of EN 15316-4-2 was issued in 2007 and the current version was published in 2017.

A draft for a major revision was prepared and submitted to CEN public enquiry at the end of 2021. Because of the scope extension to cooling mode, the draft is currently being reworked again by an active task group in CEN-TC 228 WG4 (CEN, 2017d). The release for the second public enquiry is expected within the end of 2024.

The description in the following relates to the current draft of the revision.

3.3.1.2.2 Context

This standard was originally developed in 2007 when:

- heating systems in Europe were mostly water based;
- there was no other standardised information than rated COP and capacity at full load for the operating conditions defined in EN 14511 (BSI, 2018).

The later development of EN 14825 (BSI, 2022) for product rating purpose, required some static tests at part load conditions.

Given these two different sources of product data (EN 14511 (BSI, 2018) and EN 14825 (BSI, 2022)), two calculation methods have been developed within EN 15316-4-2 (CEN, 2017c):

- the so called “path A” is based on full load performance data according to EN 14511 (BSI, 2018);
- the so called “path B” is based on part-load data according to EN 14825 (BSI, 2022).

3.3.1.2.3 Output data

For each calculation interval, EN 15316-4-2 (CEN, 2017c) provides the following output data:

- the part of the required output that can be supplied by the heat pump (the remaining load has to be provided by another generator, if available);
- the required driving energy;
- the required auxiliary energy;
- the amount of heat captured from the environment (this is required in the EU context because legally it is accounted for as use of renewable energy);
- the recoverable heat released to the conditioned space.

These results are provided separately per each service provided by the heat pump.

3.3.1.2.4 Structure and rationale

The current draft EN 15316-4-2 (CEN, 2017c) applies the following procedure for each calculation interval.

- The required energy output per each service and the duration of the calculation interval are input data coming from EN 15316-1, the general part for heating and domestic hot water systems. This makes the module usable for monthly, bin and hourly calculation intervals. Some dynamic features, like allowing to provide in the next hour the missing heat for space heating because of a simultaneous domestic hot water requirement, are available only for the hourly calculation interval.
- The source temperature is determined according to the heat pump type, and it is assumed to be an input value, either climatic data for air source heat pumps or the result of a dedicated module for other sources like e.g. ground coupled heat pump. Simple models are proposed as default options.
- The sink temperature (e.g. required leaving water temperature for water heat pumps) is calculated for each calculation interval in the general part of heating and domestic hot water systems EN 15316-1.
- For direct expansion and condensation heat pumps, the room temperature and humidity also impacts the performance. In the EN environment, these data are available for an hourly calculation interval in EN ISO 52016-1.

- The EN environment can provide a reasonably accurate calculation of the required operating conditions for each calculation interval.
- Operational and control options (e.g. temperature limits of source and sink, service scheduling, control commands) are checked to decide if the required services can be provided in the calculation interval.
- Priorities are assigned if several services are required in the calculation interval. The most common by far is domestic hot water preparation, first at full load then space heating.
- Given the operating conditions, the maximum available output is calculated for each service. This calculation depends on the selected calculation path.
 - for path A, it is based on the interpolation of a performance grid (maximum power as a function of the combination of a given number of source and sink temperatures);
 - for path B, the maximum available power is assumed to be that at the declared bivalent point (a constant value, independent from source and sink temperature).
- Given the required output per service, the available maximum power, the total calculation interval duration and the priority rules, the operation time and the part load are determined for each service.
- The driving energy input is calculated for each priority. This calculation is performed according to a selected “path” (i.e. calculation method).

The same procedure is repeated independently for each different operating condition required in the same calculation interval (e.g. space heating, domestic hot water preparation).

- **Path A** is based on a performance grid of COP at full load at a given number of source and sink temperatures according to EN 14511 (BSI, 2018) (an example is shown in Figure 3.3.1-2).

Firstly, the COP at full load $COP_{100\%,ci}$ (Equation 3.3.1.1) for the specific source and sink temperature in the calculation interval ci , is determined by interpolation of the full load performance grid.

$$COP_{100\%,ci} = f(\theta_{source,ci}; \theta_{sink,ci}) \quad (4.3.1.1)$$

Then the $COP_{100\%,ci}$ at full load is corrected to consider the effect of part load operation and modulation type. There are currently several options to perform this correction, as described in the following clauses. The COP at the actual part load COP_{ci} in the calculation interval ci can be obtained by applying a multiplication factor or by adding a correction term, depending on the calculation options.

$$COP_{ci} = COP_{100\%,ci} \cdot f_{corr;COP}(LR) \quad \text{or} \quad COP_{100\%,ci} = COP_{100\%,ci} + \Delta_{COP}(LR) \quad (3.3.1.2)$$

where LR in Equation (3.3.1.2) is the ratio of the required capacity to the maximum capacity in the same operating conditions.

Finally, the required heat output for heating $Q_{H;hp;out,ci}$ is divided by the corrected COP_{ci} to obtain the required driving energy $E_{H;hp;in,ci}$:

$$E_{H;hp;in,ci} = \frac{Q_{H;hp;out,ci}}{COP_{ci}} \quad (3.3.1.3)$$

- **Path B** is based on measurements of part load COP according to EN 14825 (BSI, 2022). Six testing points are defined, labelled A to G (see Table 3.3.1-1 for their definition), but only four with different source temperature, sink temperature and required power output $\Phi_{hp;out,X}$ are always available because of possible (and frequent) duplicates, such as bivalence point set as -7 °C so that A=F. For the available testing points X (A to G), the evaporation and condensation temperatures are estimated to get the exergetic efficiency $\eta_{exe,X}$ of the compressor.

$$\eta_{exe,X} = \frac{COP_X}{\eta_{Carnot}(\theta_{evap,X}; \theta_{cond,X})} = \frac{COP_X}{\frac{\theta_{cond,X} + 273,15}{\theta_{cond,X} - \theta_{evap,X}}} \quad (3.3.1.4)$$

The exergetic efficiency η_{exe} of the compressor is the ratio of the actual COP to the ideal Carnot COP for the same evaporation and condensation temperatures.

It is assumed that the temperature differences between

- source temperature and evaporation temperature
 - sink temperature and condensation temperature
- are proportional to the required power output.

The effect of intermittent operation is included in the exergetic efficiency of testing points with a lower capacity than minimum continuous operation. It is then assumed that the exergetic efficiency of the compressor to be a function of the required power output only.

$$\eta_{exe} = f(\Phi_{hp;out}) \quad (3.3.1.5)$$

For any power between the two test points, the exergetic efficiency is found by linear interpolation.

Given these assumptions:

- the exergetic efficiency is found for the required power output
- and the COP is calculated according to evaporation and condensation temperature in the actual operating conditions in the given calculation interval.

Finally, the required output is divided by the COP to obtain the required driving energy.

- If the heat pump output does not fully cover the required heat for any service, the possible contribution of an integrated back-up heater is calculated.
- Required auxiliary energy for external devices, such as heat capture or rejection systems, is calculated. The required input data is the auxiliary power at zero, minimum and maximum load.
- Losses to the surrounding environment are calculated.
- Results are collected to provide the required calculation results per service.

3.3.1.2.5 Required input data

The basic input data for Path A is a couple of performance grids for capacity and COP at maximum load. Source temperatures defined in EN 14511 (BIS, 2018) are -7, 2, 7 and 12 °C for air source heat pumps. Additional external temperatures may be considered for cold climates and summer operation (e.g. for domestic hot water preparation).

Typical sink temperatures are 20 °C for air heat pumps and 35, 45 and 55 °C for water heat pumps. Other source and sink temperatures are defined depending on the source and sink type.

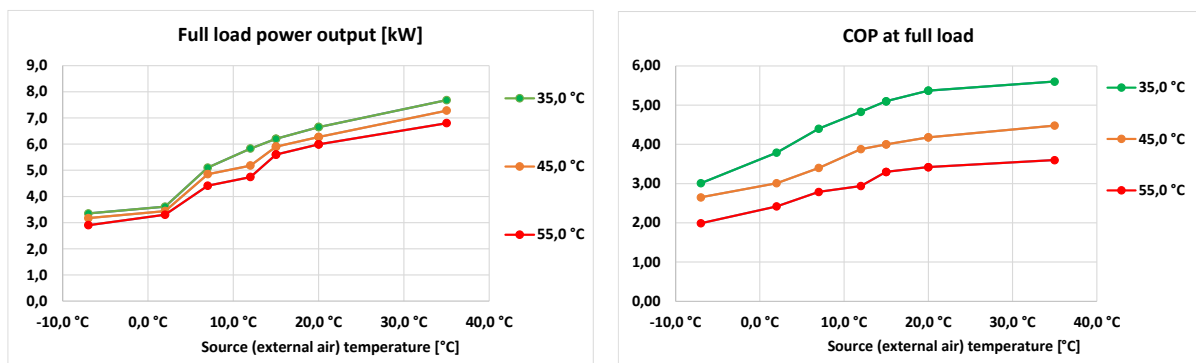

Figure 3.3.1-2. Sample full load performance grids according to EN 14511 for input to path A calculation of an air to water (AW) heat pump. Each curve is the maximum capacity or the COP of the heat pump as a function of the source temperature for a given flow temperature (LWT leaving water temperature).

3.3.1.2.6 Required input data for path B

The basic inputs for Path B are the measured COP and output power in 6 testing points according to EN 14825, some of which may be coincident. Table 3.3.1-1 shows the testing conditions (source and sink temperature) and a sample set of declared values (testing power and COP) for air to water heat pumps, modulating power, average climate, and low leaving water temperature (35 °C nominal). In the shown data-set, the manufacturer assumed a bivalence temperature (point F, BIV) of -7°C. Design external temperature (point E, DES) for the average climate is -10 °C.

Table 3.3.1-1. Test data according to EN 14825 for input to path B calculation. AW heat pump.

Point		A	B	C	D	E DES	F BIV
Source temperature	°C	-7	2	7	12	-10	-7
Sink temperature	°C	34	30	27	24	35	34
Testing power (Pd)	kW	4,6	2,9	1,9	1,9	4,2	4,6
COP (COPd)	-	3,21	4,66	6,56	8,49	2,25	3,21

Only this data set (average climate and low temperature) is used because it is mandatory for the purpose of product labelling. EN 14825 defines additional sets for different reference climates (warm climate and cold climate) and operating temperatures (medium and high) but they are optionally declared and therefore not used in the calculation. The method needs some small adaptations for the different heat pump types (AA versus AW, WW and WA).

3.3.1.2.7 Common input data to all calculation paths

Additional data required for all calculation paths are:

- descriptive data of the heat pump (e.g. type of source, main technology), to establish the calculation procedure options (namely the calculation path depending on national options);
- stand-by and crankcase heater auxiliary power in W;
- data on external auxiliaries (not included in the heat pump), usually in the shape of auxiliary power at stand-by and maximum capacity;
- maximum power of the back-up heater;
- energy carrier type for the heat pump and for the back-up heater;
- operation limits (minimum and maximum source and sink temperatures)
- control options (priority between services).

3.3.1.2.8 Correction for part load in path A

The draft EN 15316-4-2 (CEN, 2017c) contains several methods to correct the COP according to part load because there is still ongoing discussion about the most suitable method depending on the heat pump type. They are briefly discussed in the following.

The part load factor LR (load ratio) in path A is defined as the ratio of the actual required power output in the calculation interval to the maximum power output in the given operating conditions (source and sink temperature).

- Default multiplication factor of full load COP $f_{\text{corr,COP}}(\text{LR})$

This method assumes that the full load COP shall be multiplied by the correction factor $f_{\text{COP,LR}}$, which is a function of the part load ratio LR. The correction factor is assumed to be independent of any other operating conditions, that is $f_{\text{COP,LR}} = f(\text{LR})$.

Default functions $f_{\text{COP,LR}} = f(\text{LR})$ are given for absorption heat pumps (single stage and modulating) and for combustion engine driven heat pumps.

The function may be presented as a table of values, then linear interpolation is used for intermediate values of LR.

A further possibility is to calculate the correction factor with equations 28 (air source heat pumps) and 29 (water source heat pumps) of EN 14825 (BSI, 2022), which use the Cd factor to adapt the shape of the curve.

Typical values for the default correction factor are given in Figure 3.3.1-3.

This method is deemed to be most suitable for heat pumps whose COP is not severely affected by part load, such as air to water and water to water heat pumps.

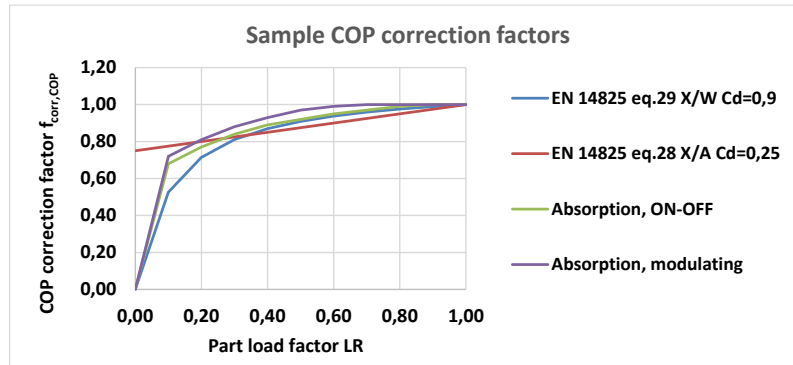

Figure 3.3.1-3. Sample COP correction factors $f_{corr,COP}(LR)$

This method does not require product data, since it is based on default functions. The parameter Cd can be optionally determined by the manufacturer according to EN 14825 (BIS, 2022).

- Default additive term $\Delta_{COP}(LR)$ (Figure 3.3.1-4)

This method is taken from DIN V 18599-5 (DIN, 2016a) and it assumes a default additive term to COP for:

- optimal load factor, assumed to be 60% of maximum load ($LR = 0,60$);
- minimum continuous operation load factor ($LR = 0,3...0,5$).

Default values of the additive term are in the following range:

- for optimal load factor: $+0,2...+0,4$
- for minimum continuous load: previous optimal correction term - $0,4...0,6$

At zero load ($LR=0,0$), the COP is assumed to be 0.

For intermediate values of the load factor LR, the COP is interpolated linearly.

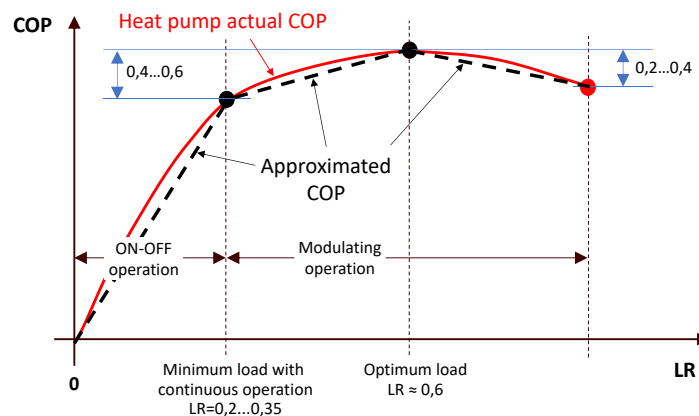

Figure 3.3.1-4. $\Delta_{COP}(LR)$ additive term according to DIN V 18599-5 (DIN, 2016a)

This method is intended for air to water heat pumps.

- Constant internal auxiliaries and COP increase at minimum load
This is the method that was included in the original EN 15316-4-2 in 2017 (CEN, 2017c). This method was taken from the French regulation RT 2012.

- First, the auxiliary energy included in the declared COP is separated from the driving energy. If not measured, this internal auxiliary energy is assumed to be 2% of the driving energy.
 - The compressor COP is calculated, considering only the net driving energy. This results in a slightly higher compressor COP than the heat pump COP.
 - It is assumed that the compressor COP will have a higher value at minimum modulation than at full load. There is a default correlation and several other proposals on how to estimate this increase, still under discussion. The result is in the range +10%...+30% for air to water heat pumps.
 - When the load is in the range between minimum continuous operation and full load, the compressor COP is considered being linear with LR and the auxiliary power constant. Net driving energy and internal auxiliary energy are summed again to determine the heat pump COP at any part load.
 - When the load is below the minimum for continuous operation,
 - either equation 29 of EN 14825 (BSI, 2022) is used to correct the COP at a minimum continuous load;
 - or the impact of intermittency is estimated according to a correlation that considers the transient during each compressor start and the type of heating terminals
- The resulting behaviour is illustrated in Figure 3.3.1-5.

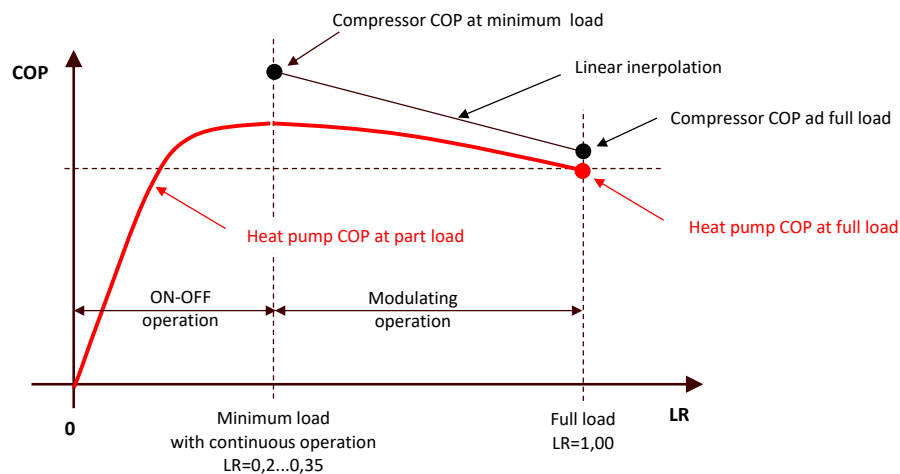

Figure 3.3.1-5 – Heat pump COP at part load for AW heat pumps with the constant internal auxiliary method of EN 15316-4-2:2017 (CEN, 2017c).

3.3.1.2.9 Sample calculation

The reaction of a calculation method to changing operating conditions can be shown by repeating the calculation for several intervals and changing one operating condition at a time. Figure 3.3.1-6 shows the calculated COP (red line, scale on the right) of an air to water heat pump with varying load (blue line, scale on the left), from 0 to 6,4 kW, for two leaving water temperature levels (30 °C and 40°C) and for three different external air temperatures (-8, 0 and +10 °C).

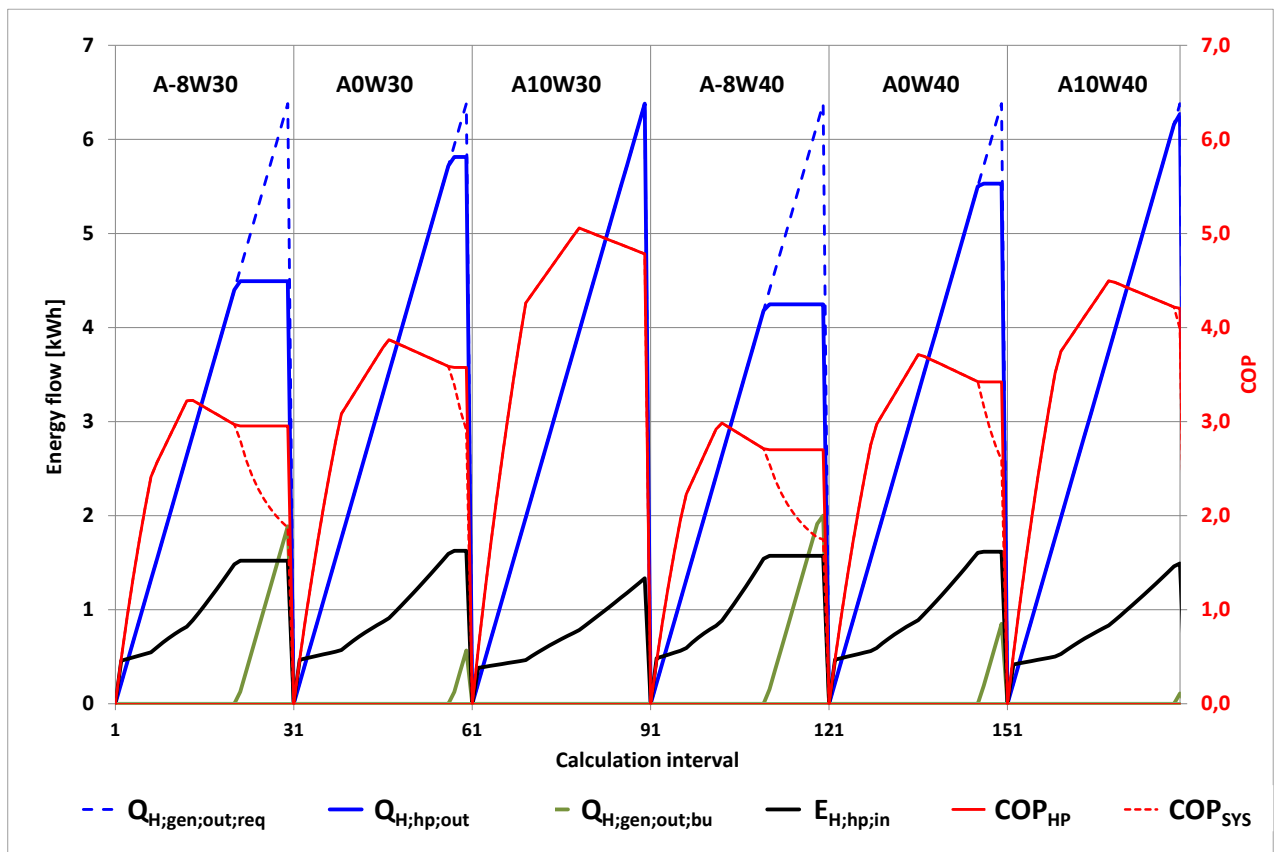

Figure 3.3.1-6. Sample calculation results

Each operating condition is identified by the code (e.g. A-8W30) on the top of the graph.

The calculation is repeated 30 times for each operating condition, linearly increasing the required heat output $Q_{H;gen;out;req}$, shown by the dashed blue line.

Depending on the air and water temperature, the actual heat pump output $Q_{H;hp;out}$, shown by the solid blue line, will be equal to the required amount and will cover it. When the maximum capacity of the heat pump is reached for the given operating conditions, the dashed blue line (required output) appears because it cannot be fulfilled by the heat pump. The graphs show clearly the high sensitivity of the maximum capacity to external temperature (A-8W30 versus A0W30 versus A10W30, maximum capacity is 4,5 kW, 5,8 kW and 6,6 kW respectively) and the smaller effect of leaving water temperature (e.g. A-8W30 versus A-8W40). When the heat pump cannot provide the required output, the back-up contribution $Q_{H;gen;out;bu}$ appears, shown by the green line. Here, an electric heater is assumed, and the electricity input can be considered equal to the heat output.

The COP of the heat pump COP_{HP} is shown by the solid red line. Again, the strong influence of both operating temperatures and part-load operation is clearly visible.

When the heat pump cannot provide the required output, the generation system efficiency COP_{SYS} appears (dashed red line), Until there is no back-up required, COP_{HP} and COP_{SYS} are equal, and the solid red line (COP_{HP}) covers the dashed red line (COP_{SYS}). When the back-up contribution increases, the system COP drops quickly.

This kind of presentation is used to test and compare energy performance calculation methods.

3.3.1.2.10 Known issues

The main issue is the coordination between the tested product data and calculation methods. Product data should be defined according to the needs of the users of the data, i.e. in coordination with the calculation methods using those data. This happened for product testing and labelling (EN 14825) but did not happen

for energy performance calculation, which has a different purpose and different data needs. Therefore, the energy performance calculation methods were developed with two alternatives to best fit the available data:

- Path A assumes that the effect of part load is independent of the source and sink temperature. There are uncertainties about how to evaluate the effect of part load and several methods are still under consideration for this feature. Path A looks suitable for AW and WW heat pumps where the sensitivity of COP to part load during continuous operation (not intermittent) is limited. Path A looks less suitable for air-to-air heat pumps where the effect of part load operation on COP can be much greater.
- Path B uses the data declared for product labelling according to EN 14825. There are only 6 data points, some of which may be duplicate, and at each point all operating conditions are changing. Additionally, they cover a marginal part of the operating range of the heat pump. Extrapolation to distant operating points has risks. Some manufacturers are willing to stick only to these points because they are already tested and declared for product classification purpose, but “safety” from official declaration does not compensate for inadequate data.

Path B requires a specific procedure for each variant of heat pump configuration (e.g. air to air, air to water inverter type, air to water on-off type).

Other issues include:

- the effect of intermittent operation (start-stop duty cycle and frequency, see item 3.2.2.3), which is currently introduced via default correlations;
- the definition of auxiliary energy needs and its connection with part load operation;
- the variety of heat pumping technologies, sources and sinks makes it difficult to design a unique and comprehensive calculation method; extensions are required to cover additional types of heat pumps, not yet explicitly covered, like heat pumps with solar assisted evaporator;
- missing connection with heat pump water heaters test data;
- additional calculation procedures are needed for special sources like the ground coupled heat exchanger. These calculation procedures are not yet fully available in the CEN environment;

3.3.1.2.11 Foreseen developments

According to the comments received during public enquiry, this standard should be extended to cover cooling (chillers), either as an alternative or simultaneous service. This means that EN 16798-13 (CEN, 2017e) (see the following) should be incorporated into or referenced by the future EN 15316-4-2 (CEN, 2017c).

A CEN working group is actively working (2024) on the revision of the standard.

3.3.1.3 EN 16798-13 (cooling mode)

3.3.1.3.1 Status

EN 16798-13 (CEN, 2017e) is the EN-EPB module covering the heat pumps in cooling mode. The first version of this standard was published in 2017 by CEN TC 156.

Following a change in the respective scopes of CEN TC 156 and CEN TC 228 (CEN, 2017d), the contents of EN 16798-13 (CEN, 2017e) should be transferred and incorporated (with possible amendments) into the new revision of the EN 15316-4-2 (CEN, 2017c), which will cover the energy performance calculation of heat pumps in both heating and cooling mode.

3.3.1.3.2 Context and background information

As for heating mode, also for cooling mode there were and there are still two possible sources of product data in the EN environment:

- EN 14511 (BSI, 2018), providing performance data at “nominal” load;
- EN 14825 (BSI, 2022), providing performance data for a selected number of part load operating conditions.

The original intent was to develop a method based on the available data for product testing according to EN 14825 (BSI, 2022). Research was performed in 2009 by Swiss experts seeking a calculation method for chillers and the outcome (Zweifel, 2009) was that the four test points of EN 14825 (BSI, 2022) could not

provide enough information to build a comprehensive performance map. The conclusion was that at least one additional point was required to complete the calibration of the performance map.

The results of this research were considered and therefore EN 16798-13 (CEN, 2017e) included:

- a method based on EN 14825 data (BSI, 2022), but requiring information in an optional additional 5th point;
- methods based on EN 14511 data (BSI, 2018);

thus, replicating the situation of EN 15316-4-2 (CEN, 2017c) for the heating mode, with path A linked to EN 14511 (BSI, 2018) and path B linked to EN 14825 (BSI, 2022).

3.3.1.3.3 Output data

For each calculation interval, EN 16798-13 (CEN, 2017e) provides the following output data:

- the required driving energy;
- the required auxiliary energy;
- the part of the required cooling output that can be supplied by the chiller (the remaining load can be provided by another generator, if available);
- the amount of heat rejected to the environment;
- the recoverable heat for heating purpose and its maximum supply temperature;
- the recoverable heat released to the conditioned space.

3.3.1.3.4 Available methods

Similarly to EN 15316-4-2 (CEN, 2017c), EN 16798-13 (CEN, 2017e) includes several calculation options to make the best possible use of available data.

- Method 1 allows the use of product data according to either EN 14511 (BSI, 2018) or EN 14825 (BSI, 2022) and is intended for the calculation in hourly intervals or temperature bins and for all possible types of cooling generators.
- Method 2 allows the use of data from EN 14511 (BSI, 2018) only and is intended for monthly or hourly calculation intervals for chillers, split and VRV/VRF systems.

3.3.1.3.5 Method 1

3.3.1.3.5.1 Method 1 rationale

If available, the method starts with the evaluation of the contribution of free cooling operation, that is providing cooling directly with the heat rejection equipment and by-passing the compressor.

The fundamental equation to calculate the driving energy input $E_{C;gen;el;in}$ for the remaining load is simply:

$$E_{C;gen;el;in} = \sum_{j=1}^n \frac{Q_{C;gen;in;j}}{EER_j} \quad (3.3.1.6)$$

There is a sum in Equation (3.3.6) because this standard also handles the option of having several chillers (or compressors) operating in parallel, each providing the amount of cooling $Q_{C;gen;in;j}$. The index j is omitted in the following for simplicity. There are several options to calculate EER_j .⁶

3.3.1.3.5.2 Method 1 using EN 14825 data

The basic assumption is that the exergetic efficiency η_{exe} of the compressor is a 3rd order polynomial function of the part load factor $f_{C;PL}$.

⁶ NOTE This standard follows the physical flow of heat in the selection of subscripts. The “chiller output” is called $Q_{C;gen;in}$ because the cooling effect (the useful output of the chiller) is an incoming heat extracted from the distribution or from the installation room.

$$\eta_{exe}(f_{C;PL}) = C_1 \cdot (f_{C;PL})^3 + C_2 \cdot (f_{C;PL})^2 + C_3 \cdot (f_{C;PL}) + C_4 \quad (3.3.1.7)$$

The constants C_1 to C_4 and the parameter $\Delta\theta_{corr}$, which is used in the following, are determined by solving a system of five linear equations whose coefficients are determined according to the test results. This requires five independent data to solve the system. Since the four test points of EN 14825 (BSI, 2022) are somehow “aligned” in the space of the operating conditions, for a good identification of the performance map of the chiller, the fifth testing point should be away from them (Zweifel, 2009 for more details). If no data is available from a suitable 5th point, EN 16798-13 (CEN, 2017e) provides the option to replace them with calculated data based on the previous 4 points.

The part load factor $f_{C;PL}$ is defined as the ratio of the required capacity to the actual maximum capacity of the chiller, depending on operating conditions.

$$f_{C;PL} = \frac{Q_{C;gen;in}}{Q_{C;gen;in;max}} = \frac{Q_{C;gen;in}}{\Phi_{C;gen;in;n} \cdot f(\theta_{rej}; \theta_{C;gen;in}) \cdot t_{ci}} \quad (3.3.1.8)$$

The function $f(\theta_{rej}; \theta_{C;evap;out})$ describes the change in capacity depending on source (evaporation) and sink (condensation, rejection) temperature. For vapor compression chillers, the change in maximum capacity is estimated according to this default equation:

$$f(\theta_{rej}; \theta_{C;gen;in}) = f(\theta_{rej}; \theta_{C;evap;out}) = \frac{\frac{273,15 + \theta_{C;evap;out}}{\theta_{rej} - \theta_{C;evap;out} + \Delta\theta_{corr}}}{\frac{273,15 + \theta_{C;evap;out;n}}{\theta_{cond;in;n} - \theta_{C;evap;out;n} + \Delta\theta_{corr}}} \quad (3.3.1.9)$$

where:

- $\theta_{C;evap;out}$ is the required leaving temperature from the evaporator;
- $\theta_{C;evap;out;n}$ is the leaving temperature from the evaporator in nominal conditions;
- θ_{rej} is the relevant rejection temperature, which is:
 - the external air temperature, for air cooled chillers;
 - the wet bulb external air temperature, for wet operation of water-cooled chillers;
- $\theta_{cond;in;n}$ is the inlet temperature to the condenser in nominal conditions;
- $\Delta\theta_{corr}$ is the additional temperature difference between evaporation and condensation due to heat transfer across the evaporator and condenser, which is calculated according to product data.

Assuming:

- $\theta_{C;evap;out;n} = 7 \text{ °C}$
- $\theta_{cond;in;n} = 35 \text{ °C}$
- $\Delta\theta_{corr} = 12 \text{ °C}$

the resulting values of $f(\theta_{rej}; \theta_{C;evap;out})$ are shown in Table 3.3.1-2.

Table 3.3.1-2. Example of values provided by Equation 3.3.1.9.

		$\theta_{rej} \text{ °C}$				
		25	30	35	40	45
$\theta_{C;evap;out} \text{ °C}$	7	1,33	1,14	1,00	0,89	0,80
	12	1,36	1,16	1,02	0,90	0,81
	17	1,38	1,18	1,04	0,92	0,83

A correlation based on empirical coefficients is provided for absorption chillers.

If the part load factor $f_{C;PL}$ is lower than the minimum for part load operation $f_{C;PL;min}$, then this minimum value is used. This means that there is no correction for intermittent operation.

It is assumed that the additional temperature differences across evaporator and condenser is proportional to the load and the value in nominal conditions is $\Delta\theta_{corr}$.

The resulting equation of the EER of a vapor compression chiller is:

$$EER = \frac{273,15 + \theta_{C;evap;out}}{\theta_{cond;in} - \theta_{C;evap;out} + f_{C;PL} \cdot \Delta\theta_{corr}} \cdot \eta_{exe}(f_{C;PL}) \quad (3.3.1.10)$$

Again, an empirical equation with default coefficients is provided for absorption chillers.

Method 1 using EN 14825 data for cooling mode is based on a similar assumption, like path B of EN 15316-4-2 (CEN, 2017c) for heating mode: the compressor exergetic efficiency is assumed to be a function of the actual load.

3.3.1.3.5.3 Method 1 using EN 14511 data

Method 1 can also be used with product data, according to EN 14511 (BSI, 2018).

The evaluation of the maximum capacity is the same.

The EER is calculated assuming constant exergetic efficiency:

$$EER = EER_n \cdot \frac{\frac{273,15 + \theta_{C;evap;out}}{\theta_{cond;in} - \theta_{C;evap;out}}}{\frac{273,15 + \theta_{C;evap;out;n}}{\theta_{cond;in;n} - \theta_{C;evap;out;n}}} \quad (3.3.1.11)$$

where the subscript “n” identifies data at nominal (rated) conditions and the other terms have the same meaning as in the previous equations.

With this option, the EER is corrected according to operating temperatures only, and there is no influence of part load.

3.3.1.3.5.4 Auxiliary energy

External auxiliaries, such as heat rejection loop pumps and fans, may be quite relevant.

Reference is made to EN 15316-3 (CEN, 2017c) for the calculation of the auxiliary energy of any circulating pump for primary loop and/or heat rejection loop.

For other heat rejection equipment (e.g. cooling tower fans), EN 16798-13 (CEN, 2017e) assumes that the auxiliary energy use be proportional to the rejected heat power. The ratio is evaluated according to rated nominal values.

3.3.1.3.6 Method 2

3.3.1.3.6.1 Auxiliary energy

Method 2 is based on the correction of the rated EER according to several factors that are assumed to be independent of each other. The fundamental equation is

$$E_{C;gen;el;in} = \frac{Q_{C;gen;in}}{PLV \cdot EER_n \cdot f_{EER;corr}} \quad (3.3.1.12)$$

where

- PLV, the “part load value”, incorporates the effect of part load operation of the compressor, rejection systems, free-cooling and cascade connection of multiple units;
- $f_{EER;corr}$ is a correction factor that takes into account the change in source and sink temperature. For vapor compression chillers the assumption is constant exergetic efficiency.

3.3.1.3.6.2 Required input data

The required input data is the rated efficiency EER_n according to EN 14511 (BSI, 2018) and a few operating parameters (e.g. source and sink temperature, auxiliary power, thermal power of the rejection system), all under nominal conditions.

Configuration and control options are also required as an input, like e.g. control mode of multiple generators, control mode of the heat rejection system.

3.3.1.3.6.3 PLV part load value

The part load value PLV is given by the equation:

$$PLV = f_{C;PL,k} \cdot f_{hr;PL} \cdot f_{hr;fc} \cdot f_{C,mult} \quad (3.3.1.13)$$

The term $f_{C;PL,k}$ accounts for the effect of part load operation of the compressor.

The relative load $f_{C;PL}$ is given by:

$$f_{C;PL} = \frac{Q_{C;gen,in}}{Q_{C;gen,in,max}} = \frac{Q_{C;gen,in}}{\Phi_{C;gen,in;n} \cdot t_{op}} \quad (3.3.1.14)$$

The relative load $f_{C;PL}$ is evaluated against the nominal capacity (instead of against the maximum capacity depending on operating temperatures, as in Method 1).

The values of $f_{C;PL,k}$ are given as a function of $f_{C;P}$ in default tables, depending on the type of chiller and on modulation options. As an example, the values of $f_{C;PL,k}$ for air cooled air conditioners are given in Table 3.3.1-3:

Table 3.3.1-3. Sample default part load factors.

Relative load $f_{C,PL}$	0,1	0,2	0,3	0,4	0,5	0,6	0,7	0,8	0,9	1,0
Type of system	Part load factor $f_{C,PL,k}$									
On-off split system	1,34	1,34	1,34	1,34	1,27	1,23	1,16	1,09	1,02	0,95
On-off multi split system	0,68	0,73	0,77	0,8	0,86	0,93	0,95	0,97	0,94	0,9
Inverter split system	1,52	1,54	1,57	1,69	1,45	1,31	1,21	1,09	1,03	0,95
Inverter multi split system	0,77	1,18	1,42	1,55	1,54	1,46	1,35	1,19	1,06	0,92

It has to be noted that due to the position of the “part load factor” $f_{C,PL,k}$ in Equations (3.3.1.13) and (3.3.1.14):

- values less than 1 mean an increase in efficiency
- values higher than 1 mean a decrease in efficiency

The term $f_{hr,PL}$ accounts for the effect of part load operation of the heat rejection system. It is given by:

$$f_{hr,PL} = a_2 \cdot \theta^2 + a_1 \cdot \theta + a_0 \quad (3.3.1.15)$$

where

- θ is a reference temperature that depends on the heat rejection type and location;
- default values of the coefficients a_2 , a_1 and a_0 are given in the informative annex B of EN 16798-13 (CEN, 2017e).

The calculation of the reference temperature depends on the heat rejection system.

The term $f_{hr,fc}$ accounts for the effect of an optional free cooling system. If there is no free-cooling, then $f_{hr,fc}=1$ (neutral value). Otherwise default values are given in annex B of EN 16798-13 (CEN, 2017e).

The term $f_{C,mult}$ accounts for the effect of the presence of multiple compressors. If there is only one compressor, then $f_{hr,mult}=1$ (neutral value). Otherwise default values are given in annex B of EN 16798-13 (CEN, 2017e).

3.3.1.3.6.4 Auxiliary energy

Depending on the chiller type, external auxiliary energy (i.e. not included in the declared COP or EER), when relevant, is considered proportional to the rejected heat and is corrected according to part load factor and to free cooling operation. Default correction factors are provided in the informative annex.

3.3.1.3.7 Known issues

The connection with product data was a main concern. Despite the effort, most features of the calculation methods, such as the correction for part load and/or operating temperatures, are controlled by default equations and default coefficients depending on the heat pump type and control options. This cancels the comparison between products and hides their specific properties, good or bad.

The method was developed and checked on big water-based chillers. It looks less suitable for small air-to-air heat pumps.

3.3.1.3.8 Foreseen developments

EN 16798-13 will be incorporated into EN 15316-4-2 (CEN, 2017c), especially to handle simultaneous heating and cooling.

For methods relying on EN 14825 (BSI, 2022), the procedure with the 5th point is being replaced by the interpolation of exergetic efficiency of the test points with the same method as for heating.

3.3.2 EnergyPlus

3.3.2.1 Status

EnergyPlus (US DOE, 2024) has its roots in both BLAST and DOE-2 programs. BLAST (Building Loads Analysis and System Thermodynamics) and DOE-2 were both developed and released in the late 1970s and early 1980s as energy and load simulation tools. BLAST was developed by the Construction Engineering Research Laboratory (CERL) and the University of Illinois while DOE-2 was developed by Berkeley Lab and many others. In the late 1990s, concerns about the limitations of BLAST and, both the metric and inch-pound versions, of DOE-2, along with the challenges of maintaining their outdated codebases, led to the decision to combine development efforts into a new program called EnergyPlus. The first release of EnergyPlus was in April 2001 (version 1.0) and has been under revision since then. The U.S. Department of Energy released the latest version (23.2.0) in September 2023.

EnergyPlus calculates the heating and cooling loads, indoor environment conditions, and equipment operations throughout a secondary HVAC system and coil loads, and the energy consumption of primary plant equipment. It is the simulation engine around which a third-party interface can be wrapped. When using EnergyPlus for demonstrating compliance with ASHRAE Standard 90.1 (ASHRAE, 2022), an appropriate interface is usually used in order to choose models in EnergyPlus and parameters for the models, which are required to do the simulation according to ASHRAE Standard 90.1 (ASHRAE, 2022).

3.3.2.2 Context and background information

EnergyPlus is an open-source building energy simulation program based on BLAST and DOE-2 (US DOE, 2024). It works as a modular system integrated with a heat balance-based zone simulation with time steps of less than an hour. IEA BESTest building load and HVAC tested EnergyPlus based on the directives of ASHRAE 140 (Method of Test for Evaluating Building Performance Simulation Software) (ASHRAE, 2023). So far, the ASHRAE 140's tests show that EnergyPlus provides reliable results with a good fit compared with actual building envelope performance parameters.

3.3.2.3 Output data

EnergyPlus has several different types of outputs, but initially, the most important ones to understand are the tabular output reports that summarise the simulation results. These reports contain monthly and annual energy consumptions of a building's main systems and equipment (lighting, air conditioning, etc.), life cycle analysis parameters, and economics.

3.3.2.4 General structure

EnergyPlus models and allows the analysis of buildings' energy consumption and environmental impacts. Its structure and rationale provide detailed insights into building performance, aiding architects, engineers, and policymakers in making informed energy efficiency and sustainability decisions.

The following items briefly explain the EnergyPlus structure.

- Input Processing:
EnergyPlus begins with the input processing stage, where users define the building geometry, materials, occupancy schedules, HVAC systems, and other relevant parameters using text-based input files. This step ensures the software accurately captures the building design's intricacies and operational characteristics.
- Simulation Engine:
EnergyPlus simulation engine employs various algorithms and computational models to simulate the dynamic interactions between the building envelope, internal systems, and external environmental conditions. It calculates energy consumption, thermal comfort, indoor air quality, and other performance metrics over time.

- Output Generation:
Upon completing the simulation, EnergyPlus generates comprehensive output reports, including graphical visualisations, tables, and text files, to present the results in a user-friendly format. These outputs allow stakeholders to analyse the performance of different building components and systems under diverse operating conditions.
- Post-Processing and Analysis:
Users can further analyse the simulation results using post-processing tools or third-party software to extract insights, identify optimisation opportunities, and compare alternative design strategies. This iterative process facilitates the refinement of building designs to achieve higher energy efficiency and occupant comfort levels.

EnergyPlus rationale is listed below:

- Accuracy and Detail:
EnergyPlus prioritises accuracy and detail in its simulation capabilities to provide reliable building performance predictions. Accounting for factors such as thermal mass, solar radiation, airflow, and occupant behaviour offers a realistic representation of how buildings behave under varying conditions.
- Flexibility and Customisation:
The software's modular structure allows users to customise simulations to specific project requirements and research objectives. Whether modelling residential homes, commercial offices, or specialised facilities, EnergyPlus offers the flexibility to incorporate diverse building typologies and system configurations.
- Support for Decision-Making:
EnergyPlus empowers users to make data-driven decisions regarding building design, retrofits, and operational strategies. By simulating the energy and environmental performance of different scenarios, stakeholders can evaluate the cost-effectiveness of various interventions and prioritize measures that yield the most significant energy savings and environmental benefits.

3.3.2.5 HVAC and heat pump energy calculation

In general, EnergyPlus represents HVAC equipment at various levels of detail and users can choose a particular model considering the complexity and available data for their simulation use case. The part-load performance of mechanical equipment, which is one of the requirements from ASHRAE Standard 90.1 (ASHRAE, 2022), is taken into consideration in EnergyPlus as shown in the following example for electric chillers. An example of energy calculation models for heat generator: Electric Chiller Model Based on Condenser Entering Temperature (object name Chiller:Electric:EIR) is presented in the EnergyPlus Documentation (US DOE, 2024)

This model simulates the performance and the power consumption of electric liquid chillers, such as reciprocating liquid chillers, centrifugal liquid chillers and screw liquid chillers. It also models the power consumption of condenser fans if modelling an air-cooler or evaporatively cooled condenser. This model does not simulate the thermal performance or the power consumption of associated pumps or cooling towers. It is said that these model and associated performance curves are developed using performance information for a specific chiller and that they should normally be used together for an EnergyPlus simulation. It is also said that changing the model's input values or swapping performance curves between chillers should be done with caution.

Power consumption ($P_{chiller}$) of an electric liquid chiller is calculated by the following equation:

$$P_{chiller}(W) = \frac{\dot{Q}_{ref}}{COP_{ref}} \times CFT \times EIRFT \times EIRPLR \times CCR \quad (3.3.2.1)$$

where \dot{Q}_{ref} is the chiller capacity at reference conditions for temperature and flow rates, COP_{ref} is the reference coefficient of performance, CFT is the cooling capacity factor as a function of temperature curve,

$EIRFT$ is the energy input to cooling output factor as a function of temperature curve, $EIRPLR$ is the energy input to cooling output as a function of part-load ratio (PLR), and CCR is the chiller cycling ratio, which is the coefficient to determine the power consumption below the minimum part load ratio.

$$CFT = a_1 + a_2(T_{cw,ls}) + a_3(T_{cw,ls})^2 + a_4(T_{cond,e}) + a_5(T_{cond,e})^2 + a_6(T_{cw,ls})(T_{cond,e}) \quad (3.3.2.2)$$

$$EIRFT = b_1 + b_2(T_{cw,ls}) + b_3(T_{cw,ls})^2 + b_4(T_{cond,e}) + b_5(T_{cond,e})^2 + b_6(T_{cw,ls})(T_{cond,e}) \quad (3.3.2.3)$$

$$EIRPLR = c_1 + c_2(PLR) + c_3(PLR)^2 \quad (3.3.2.4)$$

$$CCR = \min\left(\frac{PLR}{PLR_{min}}, 1.0\right) \quad (3.3.2.5)$$

where $T_{cw,ls}$ is the leaving chilled water setpoint temperature ($^{\circ}\text{C}$), $T_{cond,e}$ is the entering condenser fluid temperature ($^{\circ}\text{C}$), PLR is the part-load ratio = (cooling load) / (chiller's available cooling capacity), and PLR_{min} is the minimum part load ratio, below which the chiller cycles on and off to meet very small loads and the power consumption during the on cycle is the same as when the chiller is operating at the minimum part load ratio.

The performance curves for more than 160 chillers, including the default curves for reciprocating and centrifugal chillers are provided in the EnergyPlus Reference Datasets (Chillers.idf), which can be obtained when users download EnergyPlus. The performance curves were developed from information collected over a 10-year period from 1991 to 2001 based on procedures described on ARI Standard 551/591. According to the descriptions of the model (US DOE, 2024), EER (COP) values defined in AHRI 551/591 (ANSI/AHRI, 2023) are calculated at the various load capacity points (100%, 75%, 50% and 25% part-load ratios) by using the Equations (3.3.2.5.1) to (3.3.2.5.5). This relationship seems to mean indirectly that the performance curves (3.3.2.2) to (3.3.2.5.3) equivalently represent energy efficiency under various conditions of chillers as the test method prescribed in AHRI 551/591 represents. However, AHRI 551/591 (ANSI/AHRI, 2023) does not provide a method for the curve fitting of the performance data provided using its procedures. Therefore, the EnergyPlus should use a suitable method for the curve fitting in order to provide the coefficients of Equations 3.3.2.1 to 3.3.2.5.

When using EnergyPlus to verify building compliance with ASHRAE Standard 90.1 (ASHRAE, 2022) and US building energy codes, specific rules apply. According to Appendix G of ASHRAE Standard 90.1 (ASHRAE, 2022), which outlines the performance rating method using simulation programs, these programs must meet certain requirements, such as the capability to model part-load performance curves for mechanical equipment.

3.3.2.6 Required input data

EnergyPlus uses text-based files to provide inputs and outputs. The input files provide information regarding the envelope, occupation profiles, and the main parameters of lighting and air conditioning systems. The calculation requires rated values and the coefficients of the correlation curves (two correlation curves for full load performance and one for part load effect).

3.3.2.7 Known issues

While EnergyPlus is a highly regarded simulation software in building energy analysis, it is not immune to certain limitations and known issues. These issues can impact the accuracy of simulations and may require workarounds or additional scrutiny by users. Here are some of the known issues associated with EnergyPlus.

- Complexity and Learning Curve:
EnergyPlus has a steep learning curve, especially for users unfamiliar with the underlying principles of building energy simulation or the software's input syntax. The software's complexity can be daunting for beginners and may require significant time and effort to master.
- Limited Graphical Interface:

EnergyPlus lacks a fully integrated graphical interface for model creation and result visualisation. While third-party interfaces like OpenStudio and DesignBuilder offer graphical front ends, they may only cover some aspects of EnergyPlus's capabilities, leading to potential workflow inefficiencies.

- Validation and Calibration:

Despite the development team rigorously validating and testing EnergyPlus, discrepancies between simulated and measured building performance have been reported. Calibration of simulation models to match real-world data is essential but can be challenging because of uncertainties in input parameters, model assumptions, and measurement errors.

- Simulation Speed and Resource Requirements:

EnergyPlus simulations can be computationally intensive, especially for large and complex building models or simulations with high temporal resolution. Running simulations with detailed HVAC systems or incorporating advanced features like Computational Fluid Dynamics can require significant computational resources and time.

- Modelling Assumptions and Simplifications:

EnergyPlus relies on various assumptions and simplifications to model complex physical processes within buildings. While these simplifications are necessary for computational efficiency, they can introduce uncertainties and inaccuracies, particularly in scenarios where the assumptions could be better suited.

Modelling of equipment performance is often a basic polynomial curve fitting. Manufacturers usually provide tables and curves.

- Limited Weather Data Coverage:

EnergyPlus relies on weather data to simulate outdoor environmental conditions. While it provides access to a wide range of weather files from different sources, gaps in coverage for specific locations or periods may impact the accuracy of simulations conducted in those regions.

3.3.2.8 Foreseen developments

The potential areas of development for EnergyPlus are:

- Improved User Interface:

Enhancing the EnergyPlus user interface could improve accessibility and ease of use. This could involve developing more intuitive graphical tools for model creation, result visualisation, and scenario analysis, reducing the reliance on text-based input files and third-party interfaces.

- Integration with Building Information Modelling (BIM):

Integrating EnergyPlus with Building Information Modelling (BIM) software is a promising development that can streamline the building design and simulation workflow.

- Expanded Library of Components and Systems:

Future developments in EnergyPlus may include an expanded library of building components, HVAC systems, and renewable energy technologies to support more comprehensive energy simulations.

- Enhanced Performance and Scalability:

Future versions of EnergyPlus may focus on enhancing simulation performance and scalability.

- Integration with Machine Learning and Data Analytics:

EnergyPlus could integrate data-driven algorithms and offer personalised recommendations for energy-efficient building design and operation based on historical performance data and real-time sensor inputs.

- Open Data and Collaboration Initiatives:

Future developments in EnergyPlus may include initiatives to promote open data sharing, model interoperability, and collaborative research efforts. This could involve the establishment of standardised formats for sharing simulation models and results and the development of online platforms for community engagement and knowledge exchange.

3.3.3 National energy code of Canada for buildings

3.3.3.1 Foreseen developments

The NECB is a model code in the sense that it helps promote consistency among provincial and territorial energy codes for buildings. Persons involved in the design or construction of a building should consult the provincial or territorial jurisdiction concerned to determine which energy code applies.

The NECB (NCEB, 2020) succeeds in the 2017 edition (First edition was issued in 1997). The development of the NECB 2020 has been supported by the National Research Council of Canada (NRC), Natural Resources Canada, and other stakeholders. The NECB 2020 will help to improve the energy efficiency of new buildings and reduce greenhouse gas emissions, contributing to long-term benefits for both Canada's economy and the environment.

3.3.3.2 Context and background information

The NECB comprises three divisions: Division A for compliance, objectives and functional statements, Division B for acceptable solutions, and Division C for administrative provisions.

The objectives of the NECB are achieved by measures, such as those described in the acceptable solutions in Division B, that are intended to allow the building or its elements to perform the eleven functions, among which limitation of unnecessary energy consumption for heating and cooling (F95), for service water heating (F96), etc.

Buildings shall comply with

- a. the prescriptive or trade-off requirements stated for each portion of buildings (envelope, lighting, HVAC, etc.),
- b. the performance requirements stated in Part 8 of Division B, or
- c. the tiered performance requirements stated in Part 10 of Division B (for buildings whose occupancy is unknown).

According to the performance requirements (b) stated in Part 8, the annual energy consumption of the proposed buildings (to be checked for their compliance with the code) shall not exceed the building energy target (annual energy consumption) of the reference building. Calculation methods for the annual energy consumption of the proposed and reference buildings need to satisfy specifications described in Section 8.4.2.2 of Part 8.

3.3.3.3 Output data

The result is the annual energy consumption of the proposed building and the building energy target (annual energy consumption) of the reference building.

3.3.3.4 Method (structure and rationale)

In the annual energy consumption calculation for HVAC systems in the proposed building, part-load performance curves of heat sources shall be consistent with the equipment detailed in the building specifications. However, where part-load performance curves for the proposed building's system are not available, the performance curves provided in the NECB for the calculation for the building energy target of the reference building shall be used.

In Section 8.4.5 Part-Load Performance Characteristics, the performance curves for boiler, furnace, direct-expansion cooling equipment, electric chiller, cooling tower, electric air-source heat pump, absorption chiller and fuel-fired service water heater are provided.

An example of the performance curve for electric air-source heat pump (Section 8.4.5.7) is overviewed in the following:

$$P_{operating} = P_{rated} \times EIR_{FPLR} \times EIR_{FT} \times CAP_{FT_{EAS}} \quad (3.3.3.1)$$

where:

$P_{operating}$: electric input in kW of the reference heat pump

P_{rated} : rated electric input in kW at AHRI test conditions

EIR_{FPLR} : electric input ratio adjustment to rated efficiency due to changes in heat pump load, which is determined by Equation (3.3.3.2)

EIR_{FT} : electric input ratio adjustment to rated efficiency due to environmental variables, which is determined by Equation (3.3.3.3)

$CAP_{FT_{EAS}}$: heating capacity adjustment, which is determined by Equation (3.3.3.4)

The performance curves for parameters in Equation (3.3.3.1) are provided with coefficient values as follows:

$$EIR_{FPLR} = a + (b \times PLR) + (c \times PLR^2) + (d \times PLR^3) \quad (3.3.3.2)$$

Where:

PLR : part-load ratio based on available capacity (not rated capacity)

$a = 0.0856522$,

$b = 0.9388137$,

$c = -0.1834361$, and

$d = 0.1589702$.

$$EIR_{FT} = a + (b \times t_{odb}) + (c \times t_{odb}^2) + (d \times t_{odb}^3) \quad (3.3.3.3)$$

Where:

t_{odb} : outdoor-air dry-bulb temperature in °F,

$a = 2.4600298$,

$b = -0.0622539$,

$c = 0.0008800$, and

$d = -0.0000046$.

$$CAP_{FT_{EAS}} = a + (b \times t_{odb}) + (c \times t_{odb}^2) + (d \times t_{odb}^3) \quad (3.3.3.4)$$

Where:

t_{odb} : outdoor-air dry-bulb temperature in °F,

$a = 0.2536714$,

$b = 0.0104351$,

$c = 0.0001861$, and

$d = -0.0000015$.

3.3.3.5 Required input data

As already mentioned, in the annual energy consumption calculation for HVAC systems in the proposed building, part-load performance curves of heat sources shall be consistent with the equipment detailed in the building specifications. Depending on the performance curves and models, input data varies. If any consistent performance curves are not available, the performance curves for the reference building are used. In that case, for electric air-source heat pumps, as shown in the above-mentioned equations, 1) rated electric input in kW at AHRI test conditions, 2) rated capacity at AHRI test conditions, 3) present load (heat need) on heat pump, and 4) outdoor dry-bulb temperature are needed as input data.

3.3.4 Japanese standard, BECS

3.3.4.1 Status

In Japan, implementing the method of primary energy calculation for residential and non-residential buildings for compliance checking under the Building Energy Conservation Standard (hereafter abbreviated as 'BECS') as a national law was initiated in April 2013.

Compliance with the BECS shall be mandatory for all kinds of new buildings after April 2025. It means no new construction of any buildings shall be permitted without compliance with the BECS.

National calculation programs, which are called 'Web-Program' are available online (ECSC, 2024a, b), and is maintained by the Ministry of Land, Infrastructure, Transportation and Tourism (MLIT) and organisations including two national research institutes, National Institute for Land and Infrastructure Management and Building Research Institute.

3.3.4.2 Context and background information

The energy calculation programs can calculate energy uses for space heating, space cooling, ventilation, domestic hot water, lighting and elevators. They are being updated twice a year, but the calculation methods for heat pump systems for space heating and cooling and domestic hot water have not yet been changed since 2013. In this review, energy calculation methods for 1) room air conditioners (hereafter abbreviated as 'RAC' or 'RACs') (3.3.4.3), 2) heat pump systems for HVAC of non-residential buildings (3.3.4.4) and 3) heat pump water heaters called 'EcoCute' (3.3.4.5) shall be overviewed.

3.3.4.3 The energy calculation method for RACs for BECS

Room air conditioners (RACs) have become the most popular equipment for space heating, especially in mild climate regions (major climatic condition) in Japan. It is partly because they fit the Japanese lifestyle to air condition houses partially and intermittently. Therefore, reliable energy calculation methods, which can compare energy efficiencies of different equipment, including floor heating systems with boilers, have been crucial for the BECS.

3.3.4.3.1 Input and output data

The input data representing RACs' characteristics are the rated COPs for heating and for cooling based on the test standard, JIS C 9612 (JIS, 2013a). The input data representing thermal characteristics of the building envelope are overall heat loss coefficient and overall solar heat gain coefficient, which are calculated from input data for dimensions and thermal characteristics of portions of the building envelope.

The energy calculation method for RACs was developed by referring to the results of field monitoring projects (BRI, 2013).

3.3.4.3.2 Method (structure and rationale)

Figure 3.3.4-1 and Figure 3.3.4-2 are the results for a room air conditioner, which were obtained by experiments in a laboratory without fixing the compressor speed or airflow rate. A series of experiments was carried out for temperature conditions in Table 3.3.4-1 and for air conditioners of various rated capacities and manufactures.

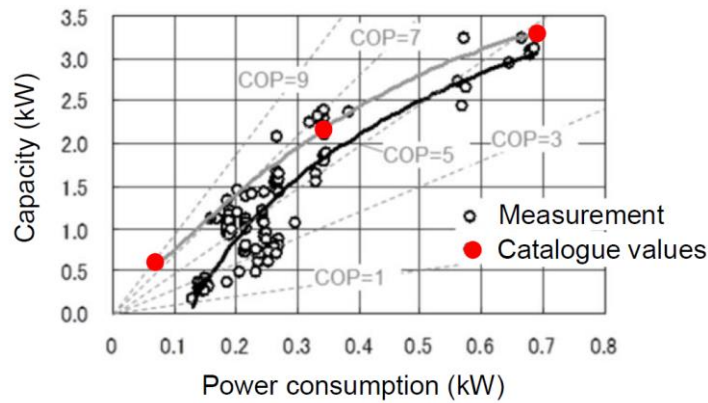

Figure 3.3.4-1. Capacity and power consumption (cooling) for a room air conditioner with the rated capacity 2.2 kW

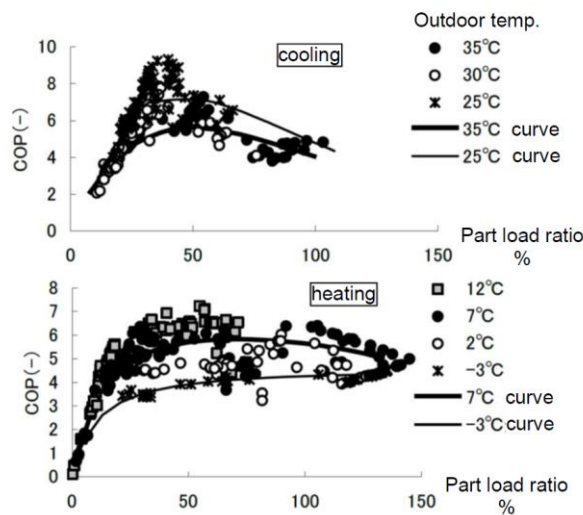

Figure 3.3.4-2. Part load ratio and COP (EER) for a room air conditioner with the rated capacity 2.2 kW

Table 3.3.4-1. Experimental conditions (temperature and humidity)

		Outdoor		Indoor	
		T.	R.H.	T.	R.H.
		[°C]	[%]	[°C]	[%]
Cooling	C-1	25	40	27	47
	C-2	30	40	27	47
	C-3	35	40	27	47
Heating	H-1	-3	87	20	59
	H-2	2	87	20	59
	H-3	7	87	20	59
	H-4	12	87	20	59

Note C-3 and H-3 are the rated conditions in JIS B 8615-1 (JIS, 2013b)

The following characteristics can be found for the room air conditioners:

- The maximum COP (EER) appears at approximately 50%-part-load-ratio to the maximum capacity,
- Below 50%-part-load-ratio, COP (EER) decreases rapidly due to increased ratio of fan power and decreased energy efficiency of compressors,
- Relative changes of COP (EER) under different outdoor temperature conditions vary according to capacities.

- The results of COP (EER) measured in the experiments are lower than values in the catalogue, which are measured according to JIS standard (JIS C 9612:2013 (JIS, 2013a)). It is partly due to lower airflow rates in the experiments. On average, the measured COP (EER) was lower than the published values by approximately 15%.

The following equations are applied in the calculation of COP at various conditions for part load ratio and outdoor temperature. The function, $f_{\theta}(L)$ is determined by the test results for a representative room air conditioner.

$$COP_i = \frac{COP_d \cdot L_r \cdot f_{\theta}(r_{\varphi})}{f_{\theta}(r_{\varphi} \cdot L_r) \cdot r_{\gamma}} \quad (3.3.4.1)$$

Where

- COP_i : COP (EER) at any part load ratio, L_r at outdoor temperature, θ
- COP_d : COP (or EER) at the rated capacity multiplied by correction factor, 0.85
- L_r : part load ratio, ratio of the capacity at the time to the rated capacity of the air conditioner
- $f_{\theta}(L)$: ratio of the power consumption (W) for part load ratio, L at the time to the rated power consumption (W) of the air conditioner
- r_{φ} : ratio of the maximum capacity (L_{Smax}) to the rated capacity (L_{Sd}) of the standard room air conditioner, divided by the ratio of the maximum capacity (L_{max}) to the rated capacity (L_d) of the room air conditioner, of which energy use is being calculated as shown by the following equation.

$$r_{\varphi} = \frac{L_{Smax}}{L_{Sd}} \div \frac{L_{max}}{L_d} \quad (3.3.4.2)$$

- r_{γ} : ratio of the power consumption at the rated capacity at outdoor temperature, θ to the power consumption at the rated capacity at the standard outdoor temperature (cooling: 35°C, heating: 7 °C).

3.3.4.3.3 Example calculations input and results

Figure 3.3.4-3 shows an example of average heating and cooling COP throughout seasons, based on the heating and cooling energy calculation (Sawachi et al., 2010). In the calculation, a wooden detached house of about 120 m² floor area with three different levels of envelope performance (insulation and solar shading) is assumed. The results shown in the figure are for the air conditioner in the living and dining room, of which the floor area is about 30 m² including the kitchen. The rated values of the air conditioner are shown in Table 3.3.4-2.

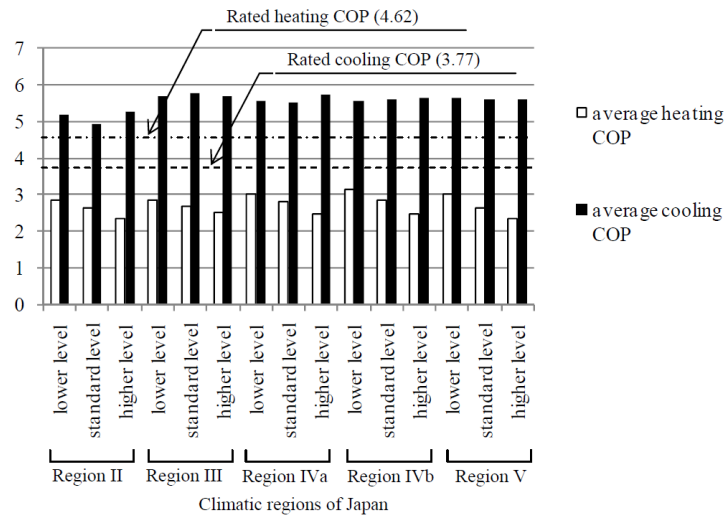

Figure 3.3.4-3. Examples of seasonal average COPs for heating and cooling for different climatic and building envelope performance ('lower', 'standard' and 'higher')

Table 3.3.4-2. Specification of the room air conditioner, of which seasonal average COPs are calculated

Rated heating COP	Rated heating capacity	Maximum heating capacity	Rated cooling COP	Rated cooling capacity	Maximum cooling capacity
4.62	6.90 kW	9.33 kW	3.77	5.60 kW	5.82 kW

3.3.4.3.4 Known issues

As mentioned above, the function, $f_{\theta}(L)$ is determined by using test results for a representative room air conditioner, but there may be room air conditioners with better energy efficiency at low part load ratio. One important issue is how the better characteristics at low partial load ratio should be certified. Before room air conditioners, for variable refrigerant flow (VRF) systems, a test protocol to certify other characteristic functions is under development as introduced in Section 1.3.4 'Load-based test to obtain the relationship between partial load ratio and energy efficiency of VRF systems by Better Living' in this report.

3.3.4.3.5 Foreseen developments

On the side of improvement of energy efficiency of room air conditioners under low part load condition, there are already some products, of which compressors have special mechanisms. There seems to be a barrier for those products to be introduced more broadly into the market, because there is a lack of a standard, which can evaluate their superiority.

3.3.4.4 The energy calculation method for residential heat pump water heaters (EcoCute) for BECS

Residential heat pump water heaters have been produced since 2001 in the Japanese market, and their accumulative number of sold units is 9.39 million units at the end of Fiscal Year 2023, according to the statistics by JRAIA (JRAIA, 2024).

3.3.4.4.1 Input and output data

JIS C 9220, 'Residential heat pump water heaters' (JIS, 2018) is the product, testing and rating standard, where annual energy efficiency e_{rtd} is defined. In the energy calculation method for BECS, as the firstly developed method, annual energy use is calculated by using a linear regression equation between e_{rtd} and the annual energy use for a four-member family. In the last stage of the calculation, the annual energy use for DHW shall be adjusted taking the total floor area of the house and expected number of family member into consideration.

3.3.4.4.2 Method (structure and rationale)

When the regression equation was made, the 30-consecutive-day hot water usage pattern, which comprises the mixture of 6 daily patterns (three patterns for 'weekday'/'holiday-to-stay'/'holiday-to-go-out' for each of two hot water daily usage volume 'large'/'small') was applied to test the amount of supplied hot water and the power consumption for summer, medium season and winter.

The test with 30-consecutive-day hot water usage pattern for three seasonal outdoor temperature conditions is a very heavy task and has been performed only when the energy calculation method should be revised. More importantly, the test shall be conducted not only for the control setting at the time of factory shipment but also the second control setting, which heats hot water in the tank up to the second lowest temperature, are used as the settings of the units to be tested.

The algorithm of the energy calculation is fully described in the published specification of the program (BRI&NILIM, 2016a).

3.3.4.4.3 Example calculations input and results

An example of energy calculation by using the Web-Program for residential buildings is shown in Figure 3.3.4-4. In this example, it is shown that the annual energy use by EcoCute with annual energy efficiency e_{rtd} of 3.5, according to JIS C 9220 (JIS, 2018) is 14,417 MJ/year, while standard energy use for this house is 25,091 MJ/year.

Step 1: 'JIS Efficiency' for the EcoCute product can be identified easily in its catalogue. The JIS Efficiency is defined together with its test method in JIS C 9220: 2018 as an input data for the building energy calculation program.

Step 2: Input the JIS Efficiency (3.5 in this example) in the screen of the building energy calculation program (below).

Catalogue value, JIS Efficiency e_{rtd} is being input.

Step 3: After starting the calculation, energy use for domestic hot water (14,417 MJ/year in primary energy basis in this example) can be obtained with energy uses for other purposes (below).

Calculated annual primary energy uses for different uses including domestic hot water in MJ/year.

domestic hot water in MJ/year.

内訳項目	設計一次	基準一次	
暖房設備	13,935 MJ	13,383 MJ	: space heating
冷房設備	6,036 MJ	5,634 MJ	: space cooling
換気設備	5,939 MJ	4,542 MJ	: ventilation
給湯設備	14,417 MJ	25,091 MJ	: domestic hot water
照明設備	5,212 MJ	10,763 MJ	: lighting
その他の設備	21,241 MJ	21,241 MJ	: other appliances
発電設備のうち 自家消費分	太陽光発電設備 (PV)	-- MJ	: generation by photovoltaic cells
	コージェネレーション設備 (CHP)	-- MJ	
	コージェネレーション設備の 発電部に係る削減分	-- MJ	
合計	PVおよびCHPを 対象とする場合 66,779 MJ	80,653 MJ	: total energy use
	CHPを対象 とする場合 66,779 MJ		

Figure 3.3.4-4. An example of energy calculation for an EcoCute (Step 1 to Step 3)

3.3.4.4.4 Known issues

The method introduced above is the initial method for energy calculation for EcoCutes and tends to make a safe side estimation of energy use. A more detailed method has been developed and is already available within the same Web-Program (BRI&NILIM, 2016a).

3.3.4.4.5 Foreseen developments

It is strongly recommended to develop testing standard(s) to certificate other characteristic curves for energy-efficient heat pump systems and other heat sources.

3.3.4.5 The energy calculation method for heat pump systems for HVAC in non-residential buildings for BECS

3.3.4.5.1 Input and output data

Heat pump systems for HVAC systems in non-residential buildings are grouped into categories, such as air-source heat pumps, absorption chillers, variable refrigerant flow systems. The input data to represent the energy performance of each heat pump system is the rated capacity, and the rated energy use for space heating and cooling according to specified testing standards.

3.3.4.5.2 Method (structure and rationale)

The heating and cooling needs calculation is done by a quasi-hourly calculation for each of the conditioned rooms in non-residential buildings. The conditions of room usage (e.g., internal heat gain, outdoor air intake, occupancy density, etc.) are defined for 201 room categories according to ISO 18523-1 (ISO, 2016). The energy use by heat and cold generators including heat pump systems is calculated by using the calculated heating and cooling needs, outdoor dry-bulb/wet-bulb temperature, part load ratio, supplied water temperature, and characteristic curves for each type of heat and cold generator (Fujii et al., 2009; BRI&NILIM, 2016b). Operating hours of heat pumps are allocated to six ranges of outdoor temperature and eleven ranges of part load ratio.

The characteristic curves for heat pump systems for cooling are exemplified in Figure 3.3.4-5.

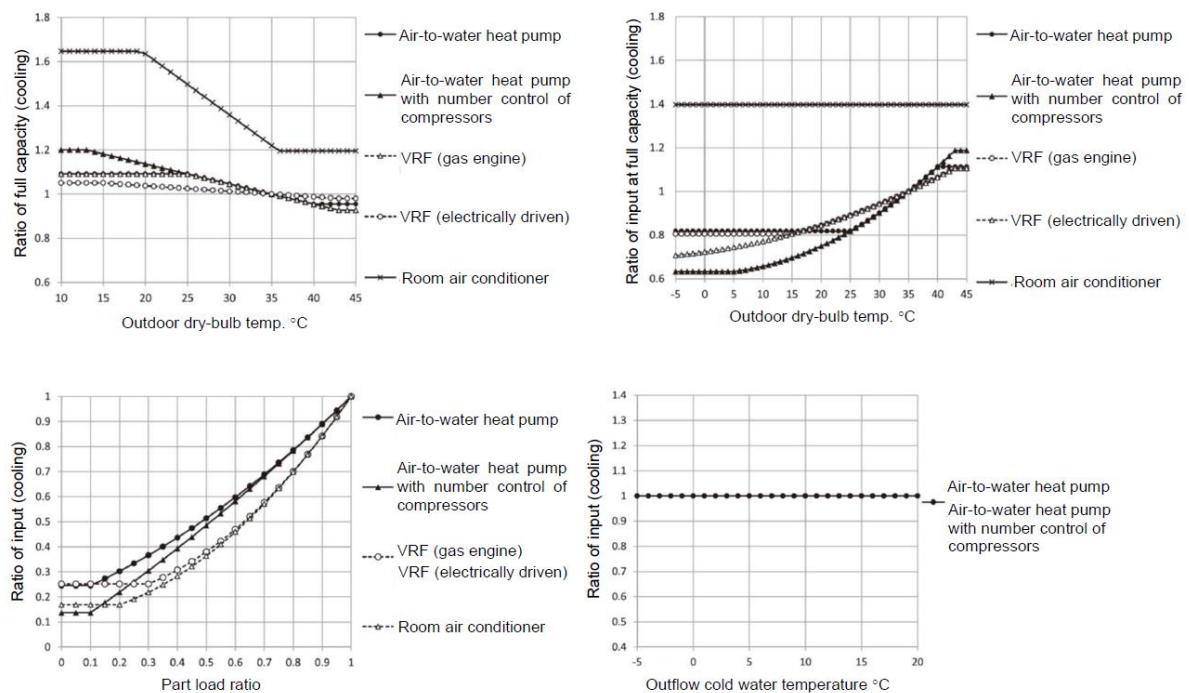
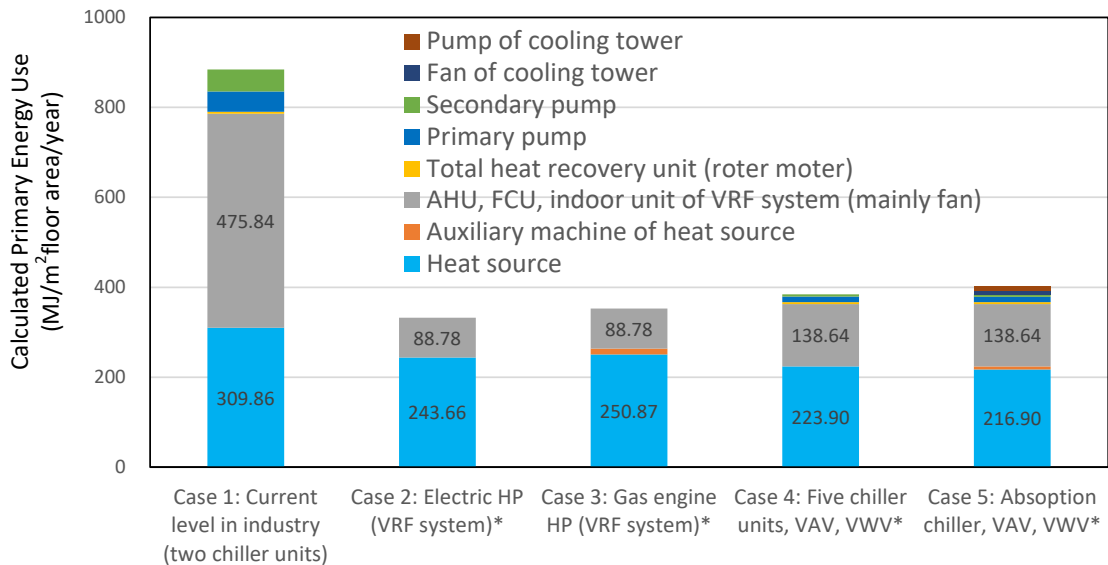

Figure 3.3.4-5. Examples of characteristic curves of heat pump systems for cooling

3.3.4.5.3 Example calculations input and results

In the example shown in Figure 3.3.4-6, energy uses for HVAC systems in an office building are calculated. Calculated energy uses for four types of HVAC systems (electric chiller, absorption chiller, electric VRF and gas engine VRF) are shown in the Figure 3.3.4-6 (BRI, 2021).



* For Case 2 to Case 5, improved building envelope is assumed, even though its contribution is not as large as HVAC systems, partly because climatic condition is rather mild.

Note. VAV: Variable Air Volume System, VWV: Variable Water Volume System, AHU: Air Handling Units, FCU: Fan Coil Units

Figure 3.3.4-6 Energy calculation of HVAC in an office building (10,000m², 7 stories, mild climate, Tokyo)

In Case 1, standard specifications are input in the program, while in other Cases more energy-efficient designs are reflected, such as sizing of fans, pumps and heat sources has been carried out according to the public design standard (MLITT, 2021). These examples demonstrated the importance of fulfilling the standardized sizing practice and the control of number of heat sources in operation, both of which contribute to higher part load ratio.

3.3.4.5.4 Known issues

The characteristic curves of heat generators including heat pumps have been used for energy calculation programs, but their evidences are not necessarily clear, even though monitoring projects (BRI, 2016) had been carried out to check their reliability as much as possible.

3.3.4.5.5 Foreseen developments

It is strongly recommended to develop testing standard(s) to certificate other characteristic curves for energy-efficient heat pump systems and other heat sources.

3.3.5 Italy UNI-TS 11300-4

3.3.5.1 Status

The energy performance calculation method for regulatory purpose is defined by the technical specification UNI-TS 11300 (UNI, 2016), which is issued by CTI (which is the historical Italian association in charge of standardization in the field of building comfort in Italy) and referenced by the regulation. The heat pump module is included in part 4, which deals with special heat generation sub-systems (other than combustion systems).

3.3.5.2 Context and background information

In Italy, the energy performance of buildings is regulated since 1976. An energy performance calculation is required for any application for a building permit since 1993. Since 2009 it is required also to issue EPCs and for deep renovations.

The whole calculation procedure of the energy performance of the building is monthly. The calculation of the heat pump is performed according to monthly bins. This is to check if the heat pump can cover the whole load and, if not, to evaluate the share of the load which is covered by the integrated back-up heater or of next generator in the priority sequence.

UNI-TS 11300 calculation method is used in the day-to-day workflow of designers and energy performance assessors in Italy. For regulatory purpose, an approved software shall be used. There are currently about 20 energy performance software in Italy, which are available by commercial entities and approved by CTI.

3.3.5.3 Output data

The output data of the heat pump module of UNI TS 11300-4 (UNI, 2016) is:

- the part of the required output that can be supplied by the heat pump;
- the required driving energy;
- the required auxiliary energy;
- the amount of heat captured from the environment;

No recoverable losses are considered.

The results of the monthly bin calculations are aggregated into monthly values.

3.3.5.4 Method (structure and rationale)

The calculation method is like path A of EN 15316-4-2 (CEN, 2017c).

The capacity and COP at full load of the heat pump ($\Phi_{100\%}$ and $COP_{100\%}$) shall be declared by the manufacturer at a set of predefined values of source and sink temperatures ($\theta_{src;ref,j}$ and $\theta_{snk;ref,i}$) which create a “grid” of reference values. The reference values for source and sink temperature are the usual ones already defined in EN 14511 (BSI, 2018). Table 3.3.5-1 shows the predefined source and sink temperature depending on source and sink type.

Table 3.3.5-1. Reference source and sink temperatures for UNI-TS 11300-4 (UNI, 2016), heating mode.

Type of source	Reference source temperatures $\theta_{src;ref,j}$				Reference sink temperatures, $\theta_{snk;ref,i}$					
					Air	Water			Domestic hot water	
External air	-7	2	7	12	20	35	45	55	45	55
Surface water and ground water		5	10	15						
Ground heat exchanger	-5	0	5	10						
Domestic hot water heaters, air source only	7	15	20	35	Not applicable				45	55

The full load capacity for the actual source and sink temperature (θ_{src} and θ_{snk} respectively) $\Phi_{100\%}(\theta_{src}; \theta_{snk})$ is calculated by linear interpolation between the nearest points.

The part load LR is calculated as the ratio of the required capacity to the full load capacity at the same source and sink temperature:

$$LR = \frac{Q_{H;gen,out;req}}{\Phi_{100\%}(\theta_{src}; \theta_{snk}) \cdot t_{ci,H}} \quad (3.3.5.1)$$

where:

- $Q_{H;gen;out;req}$ is the required heat output for heating in the calculation interval (temperature bin);
- $t_{ci;H}$ is the available time for space heating operation during the calculation interval (this is less than the entire calculation interval if the heat pump must provide other services, too).

The full load COP for the actual source and sink temperature $COP_{100\%}(\theta_{src}; \theta_{snk})$ is calculated by linear interpolation (or extrapolation) of the exergetic efficiency from the values at the nearest available reference points. The extrapolation according to source and/or sink temperature is limited to 5 °C. Example: if performance data are declared for leaving water temperature of 35 and 45 °C, the calculation can be performed only in the range 30 to 50 °C (interpolation between 35 and 45 °C plus 5°C extrapolation on both sides). A correction factor is then applied to the full load COP to consider the effect of part-load operation.

$$COP = COP_{100\%}(\theta_{src}; \theta_{snk}) \cdot f_{corr;COP}(LR) \quad (3.3.5.2)$$

There are several options to establish the correction function $f_{corr;COP}(LR)$ depending on the type of heat pump and on the availability of product data:

- a calculation based on a set of declared values of COP at full load and part load with the same sink and source temperatures, which was intended to leverage the use of data according to EN 14825;
- default correction functions;
- a correction function declared by the manufacturer;
- a recently proposed method based on the estimation of the change in evaporation and condensation temperature due to part load operation and constant exergetic efficiency.

The basic assumption is that the function $f_{corr;COP}(LR)$ does not depend on source and sink temperatures. The default correction functions $f_{corr;COP}(LR)$ in use with UNI-TS 11300-4 (UNI, 2016) are given in Figure 3.3.5-1.

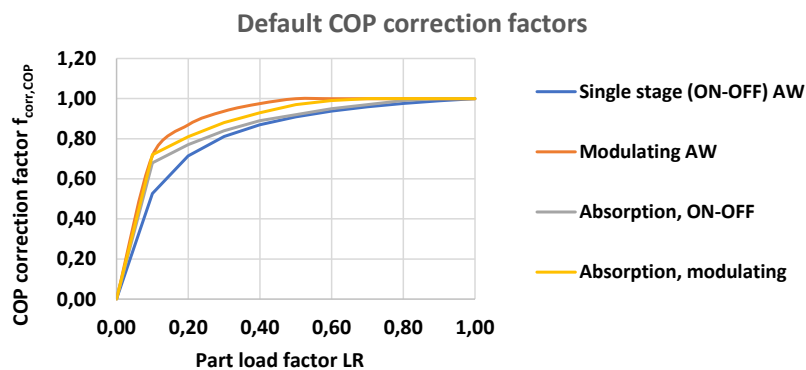

Figure 3.3.5-1. Default values of $f_{corr;COP}(LR)$ for UNI-TS 11300-4 (UNI, 2016)

The required leaving water temperature (sink temperature) for hydronic systems is calculated explicitly for each month in other parts of UNI-TS 11300-4 (UNI, 2016) and then interpolated to get the conditions in each bin. The following influence factors are considered:

- the actual size of the heat emitters (nominal power at a given average water temperature);
- the required heat emission in the calculation interval;
- the type of hydraulic circuit (e.g. direct, mixed, by-pass);
- the type of heat emission control (e.g. constant versus variable flow rate, constant versus variable flow temperature);
- the type of hydraulic connection of the generator (e.g. direct connection versus hydraulic decoupling).

Little information is provided for other sources than air (e.g. ground coupled loops, groundwater, surface water). This information shall be provided by the assessor, depending on the system's design.

3.3.5.5 Required input data

The minimum required input data is a full load performance map (capacity and COP), according to EN 14511 for the set of reference source and sink temperatures.

Optionally, the manufacturer may supply suitable information to determine the function $f_{\text{corr,COP}}(\text{LR})$.

3.3.5.6 Known issues

UNI-TS 11300-4 (UNI, 2016) was developed having in mind water-based heating systems. Thus, this calculation method is not suitable for air-to-air heat pumps, whose efficiency is strongly linked to part load operation.

An attempt has been made to extract the information of the impact of part load on COP using data declared according to EN 14825 (BSI, 2022). The result was not satisfactory because data about the test conditions of EN 14825 (BSI, 2022) also incorporate the effect of changing both source and sink temperature, making it very difficult to isolate the effect of part-load only. Also, the connection with domestic hot water heaters product data is not clear.

3.3.5.7 Foreseen developments

Italian experts are contributing to the development of EN 15316-4-2 (CEN, 2017c), in the view of referencing it in the future major revision of the UNI-TS 11300-4 (UNI, 2016) calculation method. The next major revision is expected to include the switch from monthly to hourly calculation intervals. Some years are still needed before the hourly procedure for the whole building is established and tested.

3.3.6 UK SAP 10.2

3.3.6.1 Status

The Standard Assessment Procedure (SAP) is the mandatory calculation method in force in the United Kingdom for the assessment of energy performance of residential buildings for regulatory purpose. It is therefore used in the day-to-day workflow of energy performance assessors.

SAP was developed by the Building Research Establishment (BRE) for the former Department of the Environment and was based on the BRE Domestic Energy Model (BREDEM). SAP was first published in 1993. It has been regularly updated and the current version 10.2 was published in 2022.

3.3.6.2 Context and background information

SAP procedure covers the entire calculation of the energy performance of a building. It covers heating, cooling, ventilation, domestic hot water and lighting services. The calculation interval is monthly. The overall calculation is guided by a worksheet which is presented in annex U of SAP 10.2. Intermediate results for each calculation module shall be filled in into this worksheet.

Heat pumps, as well as other emerging technologies, were included at a later stage. The details about the heat pumps calculation method are presented in appendix N of SAP 10.2.

3.3.6.3 Output data

The heat pump module provides a seasonal efficiency which is fed into the building energy performance calculation worksheet.

3.3.6.4 Method (structure and rationale)

The seasonal efficiency of any heat pump introduced on the UK market shall be pre-calculated for a number of installation options and for a set of values of the so called "Plant Size Ratio" (PSR) (BRE, 2022).

The PSR is the ratio:

- of the nominal maximum output of the heat pump,
- to the design heat loss of the building.

The PSR is an indicator of the sizing of the heat pump relative to the space heating needs. The considered values are in the range from 0,2 (undersized heat pump) to 2,0 (highly oversized heat pump).

The installation and control options include:

- the type of heat pump (air source, water source, exhaust air source),
- the emitter temperature category (35 to 70°C and warm air),
- the services provided (space heating, domestic hot water preparation and combinations thereof).

For each heat pump, identified by brand name, model name and model qualifier, the seasonal efficiency (SPF, seasonal performance factor) is calculated using an hourly method (not described in SAP 10.2) for each desired combination of PSR and installation and control option. The resulting SPF is stored in the official Product Characteristics Data-Base (PCDB). An example of such data is given in Table 3.3.6-1. (PCDB, 2024).

Table 3.3.6-1. Data found in the PCDB for a sample heat pump.

PSR (Plant Size Ratio)	0,2	0,5	0,8	1,0	1,2	1,5	2,0
Floor heating							
Heating SPF	3,855	3,926	4,173	4,217	4,241	4,191	4,108
Running hours	4925	2716	1770	1447	1231	1016	800
Radiators							
Heating SPF	3.502	3.413	3.607	3.665	3.698	3.657	3.585
Running hours	4699	2516	1643	1345	1146	947	749
Convectors							
Heating SPF	3.930	3.89	4.133	4.186	4.215	4.166	4.081
Running hours	4776	2577	1682	1376	1172	968	764

For a specific calculation, the seasonal efficiency SPF found in the PCDB is interpolated linearly according to the PSR of the specific building.

The technical documents declare compliance of the underlying hourly calculation procedure with EN 15316-4-2:2017, path B (CEN, 2017c).

The pre-calculated efficiencies are stored in the Product Characteristics Data Base (PCDB, 2024a) for use by the assessors. This approach simplifies a lot of the tasks of the assessor and guarantees the availability of suitable product data for the calculation method.

3.3.6.5 Required input data

Little input data is required: qualitative information and then model and make of the heat pump are enough to find the efficiency as a function of the PSR in Product Characteristics Data Base (SAP, 2017; SAP, 2024a; SAP, 2024b; PCDB, 2024b).

3.3.6.6 Known issues

The pre-calculated values make the calculation simple for the assessor. The downside is that the method relies on extensive assumptions (e.g. load and operation profiles) and there are few rough options to adapt the calculation to the specific case. The result is little sensitivity to the specific conditions of the evaluated building.

The calculation of heating and domestic hot water needs is monthly, but a unique seasonal efficiency is used for heat pumps. The change of COP during the heating season is not considered.

3.3.6.7 Foreseen developments

The UK government is developing a new method to increase the accuracy and robustness of the energy performance calculation of buildings: the so-called Home Energy Model (DESNZ, 2023a).

The Home Energy Model is still under development and its first version will be implemented alongside the Future Homes Standard in 2025. The heat pump module is based on EN 15316-4-2:2017 (CEN, 2017c), path B.

The Home Energy Model documentation can be found in (DESNZ, 2023a) and the specific document about heat pumps can be found in (DESNZ, 2023b).

3.3.7 Germany DIN V 18599

3.3.7.1 Germany DIN V 18599

DIN V 18599 is the German standard for the calculation of primary and final energy demand (use) for heating, cooling, ventilation, domestic hot water and lighting in buildings. The development of the standard commenced in 2002 by the committee formed by the German Federal Ministry of Transport, Building and Urban Affairs in response to European Directive 2002/91/EC on the energy performance of buildings (EPBD). The first version of DIN V 18599 was published in 2005.

3.3.7.2 Method (structure and rationale)

Calculation of energy demand (use) for heat generators for space heating differs greatly from that for space cooling. Because of the space limitation in this report, only the calculation method for space heating by heat pumps is introduced here.

The relevant calculation method for energy use for space heating is described in 6.5.3 (motor-driven heat pumps) of DIN V 18599-5 (DIN, 2016a). The calculation method for space cooling is described 7.1.3 (chillers) in DIN V 18599-7 (DIN, 2016b).

As for the motor-driven heat pumps, the following factors are considered:

- Type of heat pumps (air-water, brine-water, water-water, direct condensation, etc.);
- System configuration (priority switching of domestic hot water heating before space heating, combined operation with simultaneous domestic hot water and room heating);
- Operation in bivalent operation combined with boilers depending on outdoor temperature;
- Running time for space heating, domestic hot water heating and combined operation;
- Effects of variation of source and sink temperature on the capacity and COP;
- Effects of part-load operation of single-stage, multi-stage and continuously controlled heat pumps on the COP;
- Required auxiliary power for operation of the heat pump, which is not considered in test conditions (external auxiliaries);
- System losses due to built-in storage.

Heating energy demand for heat pumps is calculated following DIN V 18599-5 (DIN, 2016a), while energy demand for cooling is calculated following DIN V 18599-7 (DIN, 2016b) differently.

The basic procedure for calculating the energy demand for heating is divided into the following steps:

- Evaluation of source temperature (determination of outdoor temperature classes and their heating degree hours);

- Reduction of the heat output by the heat pump;
- Allocation of the heat output to the temperature classes;
- Correction of the source (e.g. outdoor temperature) and sink (e.g. room temperature) temperatures for adjusting test results of the heat pump;
- Consideration of the partial load behaviour of the heat pump;
- Calculation of running times;
- Calculation of the actual heat output, auxiliary energy use and total energy demand.

Necessary heat pump monthly heat outputs ($Q_{h, outg}$) are divided into temperature class i , which are defined as shown in Table 3.3.7-1, commonly used for all areas in Germany, by using the following equation:

$$Q_{h, outg, i} = Q_{h, outg} \cdot \left(\frac{DH_{TK, i, mth}}{HDH_{t, mth}} - k \right) \quad (3.3.7.1)$$

Where

- $Q_{h, outg, i}$ is necessary heat pump heat output for the temperature class i in the month mth ,
- $DH_{TK, i, mth}$ is the degree hours of the temperature class i in the month mth ,
- $HDH_{t, mth}$ is the total degree hours of all temperature classes in the month mth and
- k is the coverage of the second heat generator for bivalent operation.

Table 3.3.7-1. Default values for the monthly hours and the degree hours in the individual temperature classes, which are divided into the test points according to EN 14511-2 (BSI, 2018).

temperature class	W-7	W2	W7	W20	Monthly sum
Checkpoint, °C	-7	-2	7	20	
BIN temperature limits, °C	-15 to -3	-2 to 4	5 to 15 ^a	15 ^a to 32	
month	monthly hourly rate in h / degree hours in Kh				
January	156/4,103	392/7,705	196/2,335	0/0	744/14,143
February	90/2,208	436/8,239	140/1,724	6/0	672/12,171
March	41/975	337/6,172	349/4,219	17/0	744/11,366
April	4/83	142/2,527	463/4,920	111/0	720/7,530
May	0	13/224	425/3,920	306/0	744/4,144
June	0	0	301/2,470	419/0	720/2,470
July	0	0	131/921	613/0	744/921
August	0	0	146/986	598/0	744/986
September	0	0	411/3,584	309/0	720/3,584
October	0	93/1,692	597/5,955	54/0	744/7,647
November	34/824	317/6,032	369/4,606	0/0	720/11,462
December	154/3,793	424/8,171	166/2,231	0/0	744/14,195
Year	479/11,986	2,154/40,762	3,694/37,871	2,433/0	8,760/90,619

^a The temperature BIN 15 °C is split in half.

By using heat pump test results, the maximum heat output, the power consumption and the coefficient of performance of the heat pump under the checkpoint temperatures in the second line of the above table are calculated through interpolation. If such test results are not available, default values given in Appendix C of DIN V 18599-5 (DIN, 2016a) can be used.

In the next step, the load factor of temperature class i in each month (FC) is calculated as the ratio of $Q_{h, outg, i}$ to the maximum heat output of the heat pump, and the partial load factor (f_{Pint}) for each range of FC is determined by referring to the tables also given in Appendix C (Correction factors and performance figures). For electrically driven air-air heat pumps, the following table is used to determine the partial load

factor (f_{Pint}). The default values for COP at outdoor temperature ranges are also provided, such as in Table 3.3.7-2 and 3.3.7-3 for VRF systems.

Finally, the coefficient of performance ($COP_{Pint,i}$) under the load factor (FC) and the temperature class i is calculated using the following equation, and the heat pump energy use ($Q_{h,f}$) is also calculated.

$$COP_{Pint,i} = f_{Pint} \times COP_{hp,\theta_{source,max}} \quad (3.3.7.2)$$

$$Q_{h,f} = \sum_{i=1}^{n_{class}} \frac{Q_{h,outg,i}}{COP_{Pint,i}} \quad (3.3.7.3)$$

where,

- $COP_{hp,\theta_{source,max}}$ is the coefficient of performance at maximum heat output of the heat pump under the source temperature (checkpoint temperature representing each temperature class);
- n_{class} is 4, the number of temperature classes.

Table 3.3.7-2. Correction factor for partial load operation (f_{Pint}) for electrically driven outside air-room air heat pumps with direct condensation

system	Load factor FC %									
	10	20	30	40	50	60	70	80	90	100
Compact devices (window or wall)	0.39	0.6	0.7	0.75	0.78	0.82	0.85	0.88	0.93	1.0
Split systems (also simultaneous multi)	0.4	0.65	0.75	0.78	0.81	0.85	0.9	0.92	0.95	1.0
Multi-split systems	0.54	0.85	0.94	0.98	1.02	1.02	1.0	1.0	0.99	0.98
VRF systems (variable refrigerant mass flow)	0.65	1.07	1.15	1.15	1.17	1.15	1.10	1.07	1.01	0.98

Table 3.3.7-3. Default COP values for each outdoor temperature range for products

Outside temperature (inlet source temperature)	Constantly performance-regulated			
	-7 ° C	2 ° C	7 ° C	10 ° C
	w-7	w2	w7	w10
COP from 2003	3.0	3.3	3.5	3.7
COP from 1998 to 2002	2.7	2.9	3.0	3.3
COP before 1998	2.5	2.9	3.1	3.2
Utilization 100%	0.81	0.96	1.00	1.00

3.3.8 France RE 2020

3.3.8.1 France RE 2020

In France, the supporting calculation method for regulatory purpose is developed by the “Centre Scientifique et technique du Batiment” (CSTB) and adopted as a French regulation. The version currently in force is the “RE 2020”, which was published in the Official Journal of the French Government on the 15th of August 2021⁷.

⁷ Arrêté du 4 août 2021 relatif aux exigences de performance énergétique et environnementale des constructions de bâtiments en France métropolitaine et portant approbation de la méthode de calcul prévue à l'article R. 172-6 du code de la construction et de l'habitation – 15th of August 2021 - Journal officiel de la République Française

3.3.8.2 Context and background information

In France, the energy performance of buildings is regulated since 1974. An energy performance calculation is required for any application for a building permit, to issue EPCs and for deep renovations.

The text of RE2020 is written like an analysis of a calculation software because CSTB is also in charge of providing and maintaining a software kernel for the calculation of energy performance of buildings according to RE 2020. Software houses providing professional software to practitioners must incorporate the official kernel into their software (they develop only the user interface) and submit their software to a validation test.

RE 2020 applies similar (and sometimes identical) concepts and methods, but it is not directly linked to national and international technical standards (AFNOR, EN and ISO standards).

RE 2020 covers the whole building energy performance calculation for space heating, space cooling, domestic hot water preparation, ventilation, lighting, and people transport (elevators and travelators). The calculation interval is hourly. Section 8.23 of RE 2020 is dedicated to “thermodynamic generators for heating and cooling”, that is heat pumps and chillers.

RE 2020 also covers the assessment of the building environmental performance over its whole life cycle.

3.3.8.3 Output data

The module for heat pumps provides the usual results for each calculation interval:

- the part of the required heat output that can be supplied by the heat pump;
- the required driving energy, per energy carrier;
- the required auxiliary energy;
- the amount of heat captured from the environment;
- the efficiency and load factor;

No recoverable losses are considered.

3.3.8.4 Method (structure and rationale)

RE2020 covers also extensively the calculation of the temperature of the following sources (or sinks for cooling):

- external air;
- extracted air;
- indoor air of an unheated space (for domestic hot water preparation only);
- ground water;
- brine;
- water loop (a common loop to act as source and/or sink of multiple heat pumps);
- ground heat exchanger with direct expansion (heating and domestic hot water only).

The method considers a total of:

- 9 combinations of source and sinks for heating,
- 7 combinations of source and sinks for cooling,
- 6 possible sources for domestic hot water heaters.

The method is the same as path A of EN 15316-4-2:2017 (CEN, 2017c) and it is applied for both heating and cooling. The calculation of the COP or EER is performed in two basic steps:

- calculate the COP or EER at full load, with the same source and sink temperature;
- correct the full load COP or EER according to part load LR.

The full load performance map of the heat pump (both capacity and COP_{LR100} or EER_{LR100} at full load) may be generated from a single value at full load and a given source and sink temperature (the “pivot” value).

All other values in the grid are calculated by applying default multiplying factors that depend on the heat pump type. Optionally, the manufacturer can declare additional pivot values.

The pivot value provided by the manufacturer is evaluated according to the following criteria:

- it is taken as is, if the value is “certified” by an accredited organism;

- it is reduced by 10%, if the value is “justified”, that is “measured” by an accredited organism;
- it is reduced by 20%, if the value is simply declared by the manufacturer;
- otherwise, a default value is provided, depending on the technology.

Figure 3.3.8-1 shows an example of filled in values of full load COP_{LR100} for an AW heat pump with a certified pivot value of COP=4,2 at air 7°C and water 35 °C (A7W35). Since it is certified, the starting value is 4,20. Then:

- values in the next columns are obtained by multiplying the COP by factors $f_{COP;src}$;
- values in the next rows are obtained by multiplying the COP by factors $f_{COP;snk}$.

COP _{LR100}		θ_{src}					$f_{COP;snk}$	
		-15	-7	2	7	20		
θ_{snk}	25	1,94	2,42	3,87	4,84	6,05	1,10	W35 to W25
	35	1,76	2,20	3,52	4,40	5,50		
	45	1,41	1,76	2,82	3,52	4,40	0,80	W35 to W45
	55	1,13	1,41	2,25	2,82	3,52	0,80	W45 to W55
	65	0,90	1,13	1,80	2,25	2,82	0,80	W55 to W65
$f_{COP;src}$		0,80	0,625	0,80		1,25		
		A-7 to A-15	A2 to A-7	A7 to A2		A7 to A20		

Figure 3.3.8-1. Sample COP calculation table for an air to water heat pump

The COP at A-7W45 is given by: 4.40 (pivot value) x 0.80 (A7 to A2) x 0.625 (A2 to A-7) x 0.80 (W35 to W45) = 1.76

The correction of the COP or EER for part load to get COP or EER at actual load is performed with the method at constant auxiliary power of EN 15316-4-2:2017 (CEN, 2017c) and considering a multiplication factor of COP at minimum load. The default values are:

- fraction of auxiliary energy: 2%;
- minimum continuous operating load: 40% of full load (turndown ratio = 2.5);
- default increase of COP a minimum continuous load: 0%.

The manufacturer can provide certified, justified or declared values to replace the default values. Dedicated calculation procedures are provided to calculate the heat capture and/or rejection temperature.

3.3.8.5 Required input data

The method can be used with the default values only. Input values can also be declared by the manufacturer but they are derated according to the supporting evidence (certified, justified and declared values). The possible input data are:

- full load performance grid (COP and capacity) for the relevant source and sink temperature;
- fraction of auxiliary energy;
- minimum continuous operating load;
- increase of COP at minimum load.

3.3.8.6 Known issues

The derating of data according to the level of supporting documentation is introducing a bias in the calculation. Like all other methods based on full load data and then correction according to part load, the method is not suitable for air-to-air heat pumps.

3.3.8.7 Foreseen developments

French experts from CSTB are actively participating in the development of EN 15316-4-2 (CEN, 2017c). This should ensure alignment between the French method and EN standards.

3.3.9 UK SBEM for non-residential buildings

3.3.9.1 Status

SBEM is a computer program that provides an analysis of a building's energy use (UK, 2015). It was developed for the UK National Calculation Method (NCM), which is defined by the Department of Communities and Local Government (DCLG) in consultation with the Devolved Administrations (DAs-England, Wales, Scotland and Northern Ireland). The procedure for demonstrating compliance with the Building Regulations for buildings other than dwellings involves calculating the annual energy use for a proposed building and comparing it with the energy use of a "notional building". The "notional building" (or "reference building") is a building having the same size, location, orientation and operating conditions of the actual evaluated building and predefined energy efficiency properties like e.g. building envelope transmittance, HVAC system efficiency. The calculated energy performance of the notional building is assumed to be the regulatory requirement for the actual building under evaluation.

The NCM allows the calculation either by an approved simulation software or by a simplified tool based on CEN standards. The simplified tool, SBEM – Simplified Building Energy Method, was developed for DCLG by BRE.

3.3.9.2 Context and background information

The Building Regulations compliance calculation generally compares the total energy use of the building and its systems (in kWh/m²/year), expressed as carbon dioxide emissions of the building being evaluated (its "Building Emission Rate" or BER) with a target value ("Target Emission Rate" or TER) derived from similar calculations for a "notional building" (where both emission values are in kgCO₂.m²/year).

The purpose of SBEM and its basic user interface iSBEM is to produce consistent and reliable evaluations of energy use in non-residential buildings for Building Regulation Compliance and also for Building Energy Performance Certification. In introductions of relevant documents, the following caution is described:

"SBEM is a compliance procedure and not a design tool. If the performance of a particular feature is critical to the design, even if it can be represented in SBEM, it is prudent to use the most appropriate modelling tool for design purposes. In any case, SBEM should not be used for system sizing." (p.11 in *User Guide iSBEM (1) Basics – UK, 20 November 2015*)

"The need is to ensure that comparisons with the notional and other buildings are made on a standardized, consistent basis. For this reason, the energy and CO₂ emission calculations should not be regarded as predictions for the building in actual use." (p.20 in *A Technical Manual for SBEM, UK volume, 20 November 2015*)

3.3.9.3 Method (structure and rationale)

For the calculation of heating and cooling demand (load), a monthly calculation under ISO 52016-1 "Energy performance of buildings – Energy needs for heating and cooling, internal temperatures and sensible and latent heat loads – Part 1: Calculation procedures" is conducted.

Heating energy consumption is determined on a monthly basis for each HVAC system defined in the building^[34]. Having calculated the energy demand (load) for heating in each zone of the building ($Q_{NH,yr}$) as described above, the heating energy demand (load) for the HVAC system is the sum of the demands of all the zones serviced by that HVAC system (H_d in the following equation). The heating energy consumption for the HVAC system (H_e) is then calculated as follows:

$$H_e = \frac{H_d}{SCOP} \quad (3.3.9.1)$$

where *SCOP* is the Seasonal System Coefficient of Performance of the heating system, which is the ratio of the total heating need in zone(s) serviced by the HVAC system to the energy input into the heat generator(s). The *SCoP* includes generator (e.g., heat pump) efficiency, heat losses in pipework and ductwork, and duct leakage, but does not take account of energy use for fans and pumps (but does include the proportion of that energy which reappears as heat within the system). The building heating energy use will be the addition of the heating energy use of all the HVAC systems included in the building.

The *SCOP* is measured under the procedures in BS EN 14825:2013 Air conditioners, liquid chilling packages and heat pumps with electrically driven compressors for space heating and cooling. Testing and rating at part load conditions and calculation of seasonal performance. As of 2013, European Commission Regulation No 206/2012 sets standards only for *SCOP* of electrically-driven air-to-air heat pumps with an output ≤ 12 kW. There was no European test standards for part-load testing of air-to-air heat pumps with an output > 12 kW or for other types of heat pumps, and so the performance of these must be specified using *COP* obtained at the heating system rating conditions.

Cooling energy consumption is also determined on a monthly basis for each HVAC system defined in the building. Having calculated the energy need (load) for cooling in each zone of the building ($Q_{NC,yr,z}$) as described above (according to ISO 52016-1), the cooling energy demand for the HVAC system is the sum of the demands of all the zones serviced by that HVAC system (C_d in the following equation). The cooling energy consumption for the HVAC system (C_e) is then calculated as follows:

$$C_e = \frac{C_d}{SEER} \quad (3.3.9.2)$$

where *SSEER* is the Seasonal System Energy Efficiency Ratio of the cooling system, which is the ratio of the total heating need in zone(s) serviced by the HVAC system divided by the energy input into the cold generator(s) of the system. The *SSEER* takes account of the efficiency of the cold generator(s), heat gains to pipework and ductwork, and duct leakage, but does not consider energy consumption for fans and pumps. The building cooling energy consumption will be the addition of the cooling energy use of all the HVAC systems included in the building.

The value of *SEER* to be used in the SBEM tool can be calculated in several ways, according to the availability of information and the application (CEN, 2017e). In general, where an industry approved test procedure for obtaining performance measurements of cooling units at partial load conditions exists, and the cooling load profile of the proposed building is known, the *SEER* of the cooling unit is given by:

$$SEER = a(EER_{100\%}) + b(EER_{75\%}) + c(EER_{50\%}) + d(EER_{25\%}) \quad (3.3.9.3)$$

where EER_x is the *EER* measured at the load conditions of 100%, 75%, 50% and 25% at the operating conditions detailed under the part load energy efficiency ratio in Table 3.3.9-1.

Table 3.3.9-1. Operating conditions of cooling system for part load conditions

Percentage part load	25%	50%	75%	100%
Ambient air temperature (°C) for air-cooled chillers	20	25	30	35
Entering cooling water temperature (°C) for water-cooled chillers	18	22	26	30

Note: Chilled water temperatures are assumed at 7 °C out 12 °C in (at 100% load). For air cooled chillers, the relevant temperature is the outdoor temperature. For water cooled chillers, the relevant temperature is the inlet temperature of the cooling water (not the chilled water), which is assumed to be lower than air temperature because it is assumed that a cooling tower is used.

For cooling units that have no part load data, the SEER is the full load EER.

For applications where the load profile under which the cooling plant operates is not known but there is some data on chiller part load EER:

For chillers where the full and half load (50%) EERs are known, the 100% and 50% are equally weighted.

For chillers with four points of part load EER, the SEER is calculated using Equation (3.3.9.3) with each EER weighted equally, i.e., a, b, c and d each equal to 0.25.

For applications in general office-type accommodation, the following weighting factors can be taken as representative of the load profile:

a=0.03, b=0.33, c=0.41 and d=0.23

3.4 Discussion

The first evidence is the wide variety of calculation methods for the energy performance of heat pumps that have been developed independently in several countries. These methods are mostly used for regulatory purpose, as part of the energy performance calculation of the entire buildings, starting from the building envelope properties and providing the weighted energy use as primary energy and/or carbon emissions to provide comfort services (space heating and cooling, domestic hot water preparation, etc.).

None of the methods appears to be prominent: all have some to several shortcomings.

Several causes explain the current situation.

The activity of professionals involved in the installation, operation, maintenance, and renovation are mostly local as well as the building environment regulations that can be national, often regional and sometimes local to large municipalities. Products are distributed worldwide, whereas buildings stay where they are erected and the in-use energy performance of a heat pump is used as part of the characterisation of the building as a whole. This leads naturally to local developments about the in-use energy performance calculation.

Historically there has been a first interest on the performance of the building envelope. Heating and cooling needs calculation had the time to be standardised internationally and EN ISO 52016-1 (CEN, 2017a) (the new name of EN ISO 13790) is routinely used in several countries.

The standardisation on heating systems efficiency calculation started later and the massive use of heat pumps for heating is a recent development. Mechanical systems are very various and heat pumps are available and used in a wide range of different types that require different parameters for their characterisation. An additional complexity is the extreme sensitivity of the heat pump to operating conditions: an accurate and reliable calculation method of the in-use efficiency of a heat pump in a specific building with specific operating conditions must consider several parameters.

The result are substantial differences among the calculation methods related to the following aspects, which can be used as a basis for a classification:

- Calculation interval: this can be seasonal, monthly, hourly or based on temperature bins.
- Services considered: space heating, space cooling, domestic hot water preparation.
- Supported heat pump types, which are a combination of:
 - type of heat capture and/or heat rejection and related equipment: external air, exhaust air, ground heat exchanger, groundwater, surface water, cooling tower, solar assisted direct expansion, and more;
 - type of connection on the internal side of the building: indoor air (direct expansion or compression), technical water (i.e. non-domestic, just heat transfer fluid), domestic hot water;
 - type of heat pumping technology: vapor compression cycle (electric motor or combustion engine driven), absorption;

- special devices such as heat recovery (de-superheater), simultaneous heating and cooling (VRV, VRF and 4 pipes heat pumps), by-pass for free cooling.
- influence parameters considered (source temperature, sink temperature, volume of water in the installation, flow temperature control, etc.);
- basic modelling concept (independent influence of parameters (or operating conditions parameters), ...);
- connection with product data (fit for use of existing standardised product data).
- additional modelling criteria and energy performance concerns:
 - control options considered (type of capacity modulation, turndown ratio, etc.),
 - external auxiliaries calculation,
 - auxiliary calculation methods for heat capture and/or rejection devices,
 - calculation of back-up heater and checking the available capacity,
 - handling priorities between services,
 - any dynamic feature.

Table 3.4-1 summarises some features of the reviewed methods.

Table 3.4-1. Comparison of calculation methods

Method	Coverage (*)				Calc. interval	Basic modeling concept	Product data	Notes
	Services	HP type	Tech.	Other				
EN 15316-4-2	H, W	AW, WW, AA	E, A	-	M, H, B	A, B	EN 14511 EN 14825	On-going revision. Path A related to EN 14511 data, path B related to EN 14825 data.
EN 16798-13	C	AW, WW, AA	E, A	FC, M	M, H, B	A, B	EN 14511 EN 14825	
NECB	H							
BECS	C							
UNI TS 11300-4	H, W	AW, WW	E, A, C	-	B	A	EN 14511	Monthly bins UNI-TS 11300-3 for cooling
SAP 10.2	H, W	AW, AA, WW	E, A	-	S (H)	B	PDB EN 14825	Precalculated seasonal COP based on hourly calculation PDB = official Product Data Base
SBEM								
DIN V 18599	H, W, C	AW, WW, AA	E, A		M	C	EN 14511	
RE 2020	H, W, C	AW, WW, AA	E, A	Exh	H	A	EN 14511	
Energy plu	H, W, C	Any	Any		H	A		Requires modeling skills and efficiency curves.
<p>Key</p> <p>Services: H = heating C = cooling W = domestic hot water</p> <p>HP type: A = air W = water/brine G = ground heat exchanger</p> <p>Technology: E = electric compression. A = absorption C = combustion engine</p> <p>Other FC = free cooling C = cascade Exh = Exhaust air heat pump</p> <p>Interval: S = seasonal H = hourly B = Bin M = Monthly</p> <p>Influence</p> <p>Basic modeling A = Based on full load data and correction for part load B = Based on part load data processing C = Based on weighted average of test results</p> <p>(*) Main intended and/or suitable coverage.</p>								

A critical issue is the connection between product data and related testing procedures and the energy performance calculation methods. The strong and non-linear sensitivity of the heat pump performance to several parameters makes it difficult to provide enough information to identify the full performance map of a heat pump with only a few testing points. The current calculation methods make strong assumptions to simplify the required input data or to adapt to available data. This inherently limits the reliability of calculation methods to the validity interval of the underlying assumptions, which can be quite small.

To avoid or overcome this issue:

- the definition of the “heat pump” and of its product data, that is the properties that characterise the heat pump;
- the product testing method, that is the method to evaluate the defined heat pump properties;
- the product rating method, that is the determination of a single figure that allows to evaluate a heat pump and compare it against regulatory limits and other products;
- and the energy performance calculation method, that is the determination of the efficiency of the heat pump in a specific use and operating condition, should be developed simultaneously and with a strong coordination between developers of the respective standards. This is also necessary to achieve a good balance between:
 - testing effort on one side;
 - and product qualification and energy performance prediction accuracy on the other side.

Coordination of the above-mentioned standardisation aspects of heat pumps was very limited so far and happened mostly about product data and product qualification. An example of this approach is EN 14825 (BSI, 2022) that defines both the calculation method to rate a heat pump and the required testing points.

The required data for product rating and for in-use energy performance calculation may be quite different:

- product rating means calculating the efficiency of all models of heat pumps in the same representative operating conditions;
- in use energy performance calculation means calculating the efficiency of a specific heat pump in any specific operating conditions (event the wrong ones to evaluate savings deriving from e.g. correct operation and sizing).

Due to lack of coordination with test methods development, developers of calculation methods of the in-use energy performance of heat pumps had to rely just on the available product data. As an example, EN 15316-4-2 (CEN, 2017c) includes two main calculation paths precisely to adapt to the available datasets according to EN 14511 (BSI, 2018) and EN 14825 (BSI, 2022). Physical and engineering assumptions are often used to cover a wide range of application cases. In some cases, developers of energy performance calculation methods apparently did not even try to adapt: EnergyPlus seems to let the responsibility to provide a suitable empirical model of the heat pump efficiency on the user. There is little guidance in the documentation for the user on how the model shall be made or chosen for heat pumps.

A good example of the required coordination is the current development of an EN standard on instantaneous drain water heat recovery. The main application of these products is preheating the incoming domestic cold water for a shower using the warm drain water. These products recently appeared on the market and product standards and testing standards were developed by national approaches. Now two EN standards are under development simultaneously for both product testing and energy

efficiency calculation. The coordinated development resulted even in a simplification of the envisaged testing procedure.

The poor coordination between product data and in-use energy performance calculation may partly explain the gap which is often reported between calculated and measured energy performance. Another reason can be the poor commissioning and the misuse of this sensitive machine. Before investigating the gap between calculated and measured in-use performance, the calculation method should be stabilised and well connected to product data, which is not the case yet.

3.5 Perspectives of the future development of energy calculation methods for heat pump systems and harmonisation with their testing methods

Heat pumps comprise a wide and varied family of products that is far from being clearly and robustly standardised. A robust standardisation system should cover extensively and coherently:

- product definition and characterisation;
- product testing methods;
- product rating and related calculation methods;
- in-use energy performance calculation methods.

There is still a gap between tested and/or calculated efficiency and actual efficiency that can be measured in real life. This can partly be explained by the still frequent misuse and sub-optimal commissioning of heat pumps, but it is also caused by the poor coordination between product data and in-use energy performance calculations.

Several energy performance calculation standards have been developed in the different countries, but this happened independently, with little coordination with product standards, and with quite different approaches.

Based on the review of existing energy calculation methods in this Chapter, there seem at least the following three main basic modelling approaches.

- a. Starting from tested performance data at one or several nominal conditions, interpolation, extrapolation and default correlations are applied to introduce the effect of changes in operating temperatures and/or part load operation and/or other influencing factors. The effects of the different influencing factors are assumed to be independent of each other and are applied one after the other.

Examples of this approach are e.g. path A of EN 15316-4-2, EnergyPlus, NECB, BECS, UNI-TS 11300-4, RE2020, method 2 of EN 16798-13.

- b. Test results from several conditions with changing part load and temperature conditions are pre-processed to identify a characteristic function that describes the efficiency of the heat pump. Then the characteristic function is used to evaluate the efficiency in the specific operating conditions of the calculation interval.

Example: the dependency of exergetic efficiency on required heat output is determined according to several part load performance data. Then the Carnot efficiency is calculated based on operating temperatures and multiplied by the exergetic efficiency for the specific part load.

Examples of this approach are e.g., path B of EN 15316-4-2, method 1 of EN 16798-13.

- c. The seasonal efficiency is assumed to be a weighted average of heat pump efficiencies for different part load ratios.

Example of this approach is SBEM.

The basic modelling assumption relate to the required and/or available product data.

None of the current in-use energy performance calculation methods looks fully satisfactory and provides full coverage of all heat pump types.

There are a lot of ongoing activities to further develop energy performance calculation standards, but it looks like there is not enough attention and effort to coordination with product standards.

A combined research effort to identify:

- the relevant influence factors of heat pumps efficiency;
- the product data set required to quantify the influence of each factor on a specific product;
- the test procedures to identify the product data;
- the energy performance calculation method to use the data-set;

would help increase the connection between product data and energy performance calculation. In this respect, a call for experts has been launched (spring 2024) by ISO/TC 86/SC 6/WG 16, to start the development of an ISO standard titled “Data from Air Conditioning and Heat Pumps for Energy Efficiency Simulation of Building Systems”.

To further develop reliable in-use energy efficiency calculation methods for heat pumps, much more field monitoring results should be collected and referred to. Reasonable judgements on the choice of the factors to be included in the models should be based on monitoring evidence. Then the feasibility to obtain the product data to assess the impact of those factors should be taken into consideration.

It is also said that the load-based test methods for heat pumps, which are one of the focuses of Chapter 1, should be standardised and the best way to utilise the results should be searched for in the development of energy calculation methods.

3.6 References

ANSI/AHRI. ANSI/AHRI 551/591 (SI) (2023). Standard for Performance Rating of Water-chilling and Heat Pump Water-heating Packages Using the Vapor Compression Cycle. ANSI/AHR Standards, 83 pages.

ASHRAE – American Society of Heating, Refrigeration, Air Conditioning Engineers (2022). ASHRAE 90.1 – Energy Standard for Sites and Buildings Except Low-Rise Residential Buildings. ASHRAE, 468 pages.

ASHRAE – American Society of Heating, Refrigeration, Air Conditioning Engineers (2023). ASHRAE 140 - Method of Test for Evaluating Building Performance Simulation Software. ASHRAE, 468 pages.

BRI - Building Research Institute (2013). Report of Committee for Actual Energy Performance of Room Air Conditioners, 28th February 2013 (in Japanese).

BRI - Building Research Institute (2016). The Basic Study and Research to Develop an Evaluation Methodology for Energy Consumption of Commercial Buildings, Building Research Data, No.176, November 2016

BRI - Building Research Institute (2021). Design Guidelines for Energy-Efficient Non-Residential Buildings, Building Research Data, No.202, March 2021.

BRI&NILIM - Building Research Institute and National Institute for Land & Infrastructure Management (2016a). Technical information regarding evaluation of energy consumption performance in accordance with the 2016 Building Energy Conservation Standards (residential), Chapter 7 Hot Water Supply Equipment, pp.7-1-38 to 7-1-60, Available: https://www.kenken.go.jp/becc/documents/house/7-1_240401_v27.pdf, Accessed: April 2024.

BRI&NILIM - Building Research Institute and National Institute for Land & Infrastructure Management (2016b). Technical information regarding evaluation of energy consumption performance in accordance with the 2016 Building Energy Conservation Standards (non-residential buildings),

- Chapter 2 Air conditioning Equipment, Section 2.7 Primary energy consumption of heat source group, latest version released on 2024.1.22.
- BRE - Building Research Establishment (2022). The Government's Standard Assessment Procedure for Energy Rating of Dwellings, Version 10.2.
- BSI – British Standard Institution (2018). Standard BS EN 14511-Part 3: Air Conditioners, Liquid Chilling Packages and Heat Pumps for Space Heating and Cooling and Process Chillers, with Electrically Driven Compressors. Test methods.
- BSI – British Standard Institution (2022). BS EN 14825:2022: Air conditioners, liquid chilling packages and heat pumps, with electrically driven compressors, for space heating and cooling, commercial and process cooling. Testing and rating at part load conditions and calculation of seasonal performance.
- CEN - Comité Européen de Normalisation. (2014). EN 16679:2014: Packaging - Tamper verification features for medicinal product packaging.
- CEN - Comité Européen de Normalisation. (2017a). EN ISO 52016-1:2017 Energy performance of buildings. Energy needs for heating and cooling, internal temperatures and sensible and latent heat loads Calculation procedures.
- CEN - Comité Européen de Normalisation. (2017b). EN 12831-3:2017 Energy performance of buildings. Method for calculation of the design heat load Domestic hot water systems heat load and characterisation of needs, Module M8-2, M8-3.
- CEN - Comité Européen de Normalisation. (2017c). EN 15316-4-2:2017 - Energy performance of buildings - Method for calculation of system energy requirements and system efficiencies - Part 4-2: Space heating generation systems, heat pump systems, Module M3-8-2, M8-8-2 – 2017 – CEN.
- CEN - Comité Européen de Normalisation. (2017d). CEN/TC 228/WG 4 - Calculation methods and system performance and evaluation.
- CEN - Comité Européen de Normalisation. (2017e). EN 16798-13:2017 - Energy performance of buildings - Part 13: Module M4-8 - Calculation of cooling systems – Generation – 2017 – CEN.
- DESNZ - Department for Energy Security and Net Zero (2023a). Home energy model documentation. Available: <https://www.gov.uk/government/publications/home-energy-model-technical-documentation>
- DESNZ - Department for Energy Security and Net Zero (2023b). Modelling Heat pumps within the Home Energy Model - A technical explanation of the methodology. Available: <https://assets.publishing.service.gov.uk/media/6583f139ed3c3400d3bfcc6/hem-tp-12-heat-pump-methodology.pdf>
- DIN - Deutsches Institut für Normung (2016a). DIN V 18599-5 Energy efficiency of buildings – Calculation of the net, final and primary energy demand for heating, cooling, ventilation, domestic hot water and lighting – Part 5: Final energy demand of heating systems, October 2016.
- DIN - Deutsches Institut für Normung (2016b). DIN V 18599-7 Energy efficiency of buildings – Calculation of the net, final and primary energy demand for heating, cooling, ventilation, domestic hot water and lighting – Part 7: Final energy demand of air-handling and air-conditioning systems for non-residential buildings, October 2016.
- ECSC - Energy Conservation Support Center (2024a). Housing Energy Standards. Available on: <https://house.lowenergy.jp/>. Accessed: July 1st, 2024.
- ECSC - Energy Conservation Support Center (2024b). Regarding non-residential buildings energy saving standards. Available on <https://building.lowenergy.jp/>, Accessed: July 1st, 2024.
- Fujii, T.; Murakami, S.; Ishino, H.; Yanai, T. (2009). Development of an integrated energy simulation tool for buildings and MEP systems, the BEST, (Part 51), Characteristics of heat source appliances and packaged air conditioners, Proceedings of Annual Conference of SHASE, pp.687-690, 2009.9 (in Japanese)

JIS - Japanese Industrial Standards (2013a). JIS C 9612-2013, Room air conditioners. 72 pages, (in Japanese).

JIS - Japanese Industrial Standards (2013b). JIS B 8615-1: 2013, Air conditioner Part 1: Direct-blow air conditioners and Heat pumps - Rated performance and operational performance test methods non-ducted air conditioners and heat pumps Testing and rating for performance. 72 pages, 2013 (in Japanese).

JIS - Japanese Industrial Standards (2018). JIS C 9220-2018, Residential heat pump water heaters. 90 pages, 2018 (in Japanese).

JRAIA – Statistics (2024). Available: <https://www.jraia.or.jp/statistic/> (in Japanese)

ISO – International Standard Organization (2016). ISO 18523-1:2016, Energy performance of buildings, Schedule and condition of building, zone and space usage for energy calculation, Part 1 Non-residential buildings

MLIT - Ministry of Land, Infrastructure, Transportation and Tourism (2021). Design Standard for Building Equipment.

NECB - National Energy Code of Canada for buildings 2020 (2020), Canadian Commission on Building and Fire Codes, National Research Council of Canada.

PCDB - Product Characteristics Database (2024a). Available: <https://www.ncm-pcdb.org.uk/sap/download>.

PCDB - Product Characteristics Database (2024b). Building Energy Performance Assessment - Support Website, Available: <https://www.ncm-pcdb.org.uk/sap/podpage.jsp?id=6>.

SAP - System Applications and Products (2017). SAP revised heat pump performance method – Issue 1.2 – 2017. https://r.search.yahoo.com/_ylt=AwrNYfM0wdxmLAQAwdBz6Qt.;_ylu=Y29sbwNiZjEEcG9zAzEEdnRpZA-MEc2VjA3Ny/RV=2/RE=1726953013/RO=10/RU=https%3a%2f%2fwww.ncm-pcdb.org.uk%2fsap%2ffilelibrary%2fpdf%2fCalculation_Methodology%2fSAP_2012%2fCALCM-01---SAP-REVISED-HEAT-PUMP-PERFORMANCE-METHOD---V1.2.pdf/RK=2/RS=t3psQfCILrz7vg5fwbUUgljJXE-

SAP - System Applications and Products (2024a). SAP Support website. Available: <https://www.ncm-pcdb.org.uk/sap/index.jsp>.

SAP - System Applications and Products (2024b). SAP Technical documents: <https://www.ncm-pcdb.org.uk/sap/podpage.jsp?id=5>

Sawachi, T.; Miura, H.; Hosoi, A.; Habara, H. (2010). Actual Effectiveness of Heat Pump Systems for Energy Conservation in Buildings, 2010 International Symposium on Next-generation Air Conditioning and Refrigeration Technology, 17-19 February 2010, Tokyo, Japan.

UNI - UNI/TS 11300-4:2016 (2016). Prestazioni energetiche degli edifici - Parte 4: Utilizzo di energie rinnovabili e di altri metodi di generazione per la climatizzazione invernale e per la produzione di acqua calda sanitaria – 2016 – UNI.

Zweifel, G (2009). A simple chiller model for hourly time step applications. Proceedings of 11th International IBPSA Conference -2009, pages 420-427, Glasgow, Scotland.

US DOE– U.S. Department of Energy, US. Engineering Reference. (2024). Energyplus™ Version 24.1.0 Documentation, U.S. Department of Energy.

UK – UK Government (2013). Non-Domestic Building Services Compliance Guide:2013 Edition

UK - UK Government (2015). How to use iSBEM: (2) Compliance Assessment – UK, 20 November 2015.

4. State of the art on design guidelines for heat pump systems in buildings

4.1 Background

Heat pump systems play a crucial role in buildings by significantly reducing greenhouse gas emissions. They achieve this by efficiently transferring heat from one location to another. Heat pumps are versatile systems that can provide cooling and heating, making them suitable for various climates and seasons. Heat pumps extract heat from indoor spaces and reject it to the outdoor air, water bodies, or the ground in cooling applications. Heat pumps upgrade the freely available ambient energy from outdoor air, water sources, or the ground in heating applications. This utilisation of ambient energy results in lower energy consumption and higher energy efficiency compared to traditional heating and cooling systems. Heat pumps can be powered by renewable electricity sources, such as solar PV panels or wind turbines.

Design guidelines are crucial in achieving energy-efficient designs, guaranteeing occupant comfort, minimising environmental impact, and adhering to applicable building codes and regulations. These guidelines should aid in the design, installation, and maintenance of heat pump systems within buildings. As modern technologies and research continue to emerge, these guidelines continuously evolve. The aim of Chapter 4 is to present current design guidelines for heat pump systems in buildings and suggest potential future advancements.

In Section 4.2, the current guidelines are briefly presented and discussed; they are as follows:

- EN 15450:2007 – Heating systems in buildings – Design of heat pump heating systems (CEN - Comité Européen de Normalisation, 2007).
- VDI 4645:2023-07 – Heating systems with heat pumps in single and multi-family houses – Planning, construction, operation (VDI - Verein Deutscher Ingenieure, 2023).
- The standards applied in Denmark: EN14511, EN14825, EN16147, and EN12102.
- CSA SPE-17:23 – HVAC guide for Part 9 homes (CSA - Canadian Standards Association Group, 2023).
- ACCA Manuals.
 - Manual J – Residential Load Calculation (ACCA, 2016, 8th Ed, Full).
 - Manual S – Residential Equipment Selection (ACCA, 2023, 3rd Ed, V 1.01)¹.
- NEEP Sizing and Installation Guidance – Developed by the Northeast Energy Efficiency Partnership (NEEP, 2020a, b).
- ISO 13153:2012 – Framework of the design process for energy-saving single-family residential and small commercial buildings (ISO, 2012).
- Design Guidelines for Low Energy Housing with Validated Effectiveness (LEHVE) – Developed by the Building Research Institute in Japan (BRI Japan, 2010)

Section 4.3 summarises the characteristics of existing guidelines and presents perspectives on developing design guidelines for heat pump systems in Annex 88.

4.2 Existing guidelines for designers and installers of heat pump systems in buildings

4.2.1 European guidelines

For a decade, designers and installers are facing a new task in Europe (eventually maybe everywhere in the world), urged by new regulations: the use of heat pumps instead of fossil fuel combustion boilers as the basic heat generation device. In several EU countries fossil fuel boilers are already banned from new buildings, either explicitly (no natural gas connection allowed for new buildings, as e.g., in the Netherlands) or implicitly (you cannot meet energy performance requirements for new buildings with fossil fuel boilers in Italy). The new EPBD Directive 2024/1275/EU (published on the 8th of May 2024) bans combustion of fossil fuels:

- in all new buildings, starting from 2030;
- in all existing buildings (with few exceptions), starting from 2050.

Heat pumps are already in use for a long time for cooling air conditioning, but this is mostly:

- simple split or multi-split room air conditioners in individual dwellings.
This is a large market, especially in southern Europe, but the installation is simple and straightforward and requires low expertise of installers and no regular design activity (meaning that design decisions are simple and taken by the installer without the help of a professional designer);
- cooling systems in non-residential buildings.
Expertise is required from designers and installers, but it is a small market as the number of professionals involved.

Also, most of Europe does not require serious cooling.

Most installers and designers were used to boilers only, which are easy and inexpensive to install. Modern boilers are powerful devices, capable of operation at high temperature, highly modulating, little sensitive to operating conditions. Commissioning activity requires knowledge of combustion technology.

Now installers and designers must switch to heat pumps also for heating. This means:

- changing the basic technology: every installer and designer shall become a refrigeration engineer;
- dealing with sizing a still expensive machine (cost per kW installed), with little modulation, low power and extremely sensitive to operating conditions;
- dealing with a machine that requires a low flow temperature, which is often tough to achieve on existing buildings (may require insulation, continuous operation, replacement of heat emission terminals);
- facing additional technical (and bureaucratic) challenges because of environmental and safety aspects of refrigerants, which have already changed several times in the last few years;
- finding room for the heat pump and the domestic hot water storage in existing buildings where the boiler was incorporated in the kitchen furniture and domestic hot water preparation was instantaneous, with no space consuming storage;

and more, especially for existing buildings.

This is a cultural shift that should occur quickly, in a shorter time than is required for a new generation of installers and designers to appear on the market.

In this context, information, training, guidelines, and new standards provide essential support, but they all follow a similar evolution and require experience to be effectively developed. Installers and designer associations are aware of that and for a decade there have been plenty of organisations producing independent documentation, guidelines, checklists to support heat pumps installation and design. Some trends can be identified in this production.

- The first concern is the sizing of the heat pump for heating. Boilers were sized according to “heat load” calculated according to EN 12831 (CEN, 2017a). This means neglecting any gains and assuming all heat losses (e.g., ventilation) in worst-case conditions. The result was oversizing, which is no or little harm for boilers but has severe consequences on heat pumps. It must be noted that this is a topic centred on building enclosure characteristics. New sizing techniques appear based on energy performance calculation (monthly or hourly and dynamic) and on measured energy performance (for renovation of existing buildings). Manufacturers are already using extensively tools based on past energy used to advise designers and installers on heat pump sizing.
- The sizing for domestic hot water storage could be simplified in the past because of the high capacity of combustion boilers. New dynamic sizing techniques appear for non-residential applications.
- The operating temperature of the system shall be designed (new buildings) or checked (renovation of existing buildings). This requires additional calculations involving the required heat output of terminals, their sizing, the type of hydraulic circuits (both distribution and generator connection) and their control.
- Selection and handling of refrigerants is strictly regulated and is increasingly a practical (and bureaucratic) concern. Unfortunately, environmentally friendly refrigerants are toxic or explosive or require special operating conditions.

All these aspects are being dealt in more and more detail in the guidelines and standards. Most publications deal with specific aspects, but when you must design and install a heat pump system, you must consider them all simultaneously. Newly published guidelines are also getting increasingly comprehensive.

An example of this evolution is the European standard EN 15450 which is described in the next clause. Starting from a simple standard replicating most of the concepts already in use for boilers (like using heat load for sizing) it is evolving into a comprehensive guideline covering the whole design process of a heat pump installation, including aspects like using special sizing techniques, designing the operating temperature, taking care of environmental and safety aspects.

4.2.1.1 EN 15450 Heating system in buildings – Design of heat pump heating systems

4.2.1.1.1 Introduction and status of the standard

EN 15450 is the European standard dedicated to the design of heat pump systems. It complements EN 12828 (CEN, 2014) which is about the design of space heating and domestic hot water systems, with specific provisions concerning the use of heat pumps.

EN 15450 was first published in 2007 and is now (year 2024) undergoing a major revision. A new draft for public review is expected within the end of 2024. Since the revision will introduce several improvements and new concepts, the anticipated revision is also covered in the following discussion. In the European context, water-based heating systems are by far the most common. Air based heating systems have an increasing share but are still a minority. Therefore, even if air-based systems are within its declared scope, the focus of EN 15450 is mainly on water-based systems.

4.2.1.1.2 Structure and contents of the current version of EN 15450:2007

The scope of the current version includes heat pumps for space heating and domestic water heating with all popular combinations of sources (heat extraction) and sinks (heat rejection).

The following objectives of the heat pump design process are considered:

- maximising the seasonal efficiency calculated according to EN 15316-4-2, which is the European module about the energy performance of heat pumps generation systems; minimum values and target values, depending on source and sink type, are given in informative annex C to EN 15450;
- limiting the cycling frequency during part load operation;
- minimising the environmental impact (e.g. ozone depletion, global warming, noise).

The sizing of the heat pump for the space heating service is based on the heat load Φ_{HL} calculated according to EN 12831 (CEN, 2017a). This value can be slightly corrected by a “design factor” according to EN 12828 (CEN, 2014), which allows a reduction in the sizing up to 10%, depending on the specific heat capacity of the building in $\text{Wh m}^{-3}\cdot\text{K}^{-1}$. This is a critical issue because the sizing according to heat load is often excessive, because it neglects the contribution of internal gains and the limited number of hours during the heating season that are at or near the design outdoor temperature.

Two possibilities are given for the sizing of the domestic hot water storage volume:

- accumulation, where the volume is set as twice the average domestic hot water daily volume need;
- semi accumulation, where the volume is set as equal to the average domestic hot water daily volume need.

The additional design power for domestic hot water of the heat pump depends on the previous choice:

- for accumulation systems, the additional power required is equal to the average power required to heat the average daily volume of domestic hot water;
- for semi accumulation systems, a check is required that the heat pump can reload the storage in between critical draw-offs.

Minimal information is given for domestic hot water service sizing (25 litres per person and per day at 60 °C), and it is specific for residential context.

Informative annexes provide complementary information about topics such as:

- using special sources, like ground water and ground;
- typical hydraulic circuits (a collection of basic functional diagrams);
- definition and scope of performance factors;
- seasonal performance factor (SPF) recommended targets;
- noise limits;
- domestic hot water tapping (draw) patterns;
- basic definitions of capacity control.

The contents of this standard are basic and often incomplete. Also, there is no specific requirement and/or advice about the connection with heating terminals and their specific sizing that might be required for use with heat pumps. The standard needed a revision, and this work started in 2022.

The following clause describes the new draft. The standard is being also revised because of the extension of the scope of CEN-TC 228 (CEN, 2017d), which now also includes water-based cooling.

The new EN 15450 will be about water-based and direct condensation and expansion heating and cooling systems.

4.2.1.1.3 Structure and contents of the new standard

The ongoing revision of EN 15450 has several objectives:

- extending the standard to water-based cooling systems;
- identifying all the concerns when designing a heat pump system;
- dealing with the specific issues of the building renovation and of the replacement of combustion boilers by heat pumps;
- introducing a two step-procedure for existing buildings: start with a preliminary design and then decide if to proceed with a final design of a heat pump system;
- defining a procedure which is more aligned with the design workflow practice.

The introductory part covers heat pump nomenclature, system boundaries and definitions of efficiencies. The intent is to clarify the scope of COP when specifying design energy performance requirements. The design objective is not limited to the heat pump: it includes the so called “external auxiliaries”, that is electricity use for heat source and heat rejection systems that are required for system operation.

The main design objective is identified as achieving the highest seasonal performance given the design constraints and expected operating conditions.

The issues that must be considered and solved when designing a heat pump system are identified and potential consequences highlighted. No solution is provided at this stage, since providing solutions for the specific case will be the task of the design process. The following issues are identified.

- Optimising source and sink temperature, by selecting the type of source and sink and, if possible, acting on its operating conditions. This includes (e.g.) sizing the heating terminals and/or insulating the building to reduce the required fluid temperature. Each one °C is worth between 2 and 3% of efficiency.
- Heat pump sizing: Over-sizing is detrimental for investment cost, efficiency, and expected lifespan.
- Provision of a sufficient flow rate in the primary loop to avoid unintended mixing.
- Provision of a sufficient available water volume, to limit cycling frequency at low loads and to allow defrosting.
- Environmental impacts, such as noise, use of toxic chemicals, refrigerant issues (e.g. GWP, Global Warming Potential), risk of ground and groundwater contamination (for ground coupled heat pumps)
- Service specific issues that arise in connection with the provision of one specific service (e.g. space heating, domestic water heating) or a combination thereof. Example: if two levels of temperature are required (most common: low temperature space heating and higher temperature domestic water heating), consider either alternate operation modes or the use of separate, dedicated heat pumps.
- Safety aspects, including fire hazards and toxicity because of refrigerant properties. Referring to EN 378-1 for this topic.

A checklist is proposed to confirm that the design covers all relevant issues (quality check).

Information collection is the first step in the design workflow and it details design objectives and boundary conditions. This includes required services (space heating, cooling, domestic water heating) and their level, user requirements and expectations, applicable regulations and legal constraints, performance objectives, site characteristics, available resources (heat source and driving energy).

The next phase of the proposed design workflow, the preliminary design, is the provision of a so called “design concept”, that is the rationale to fulfil the design objectives. The design concept should include at least the following:

- a functional diagram as shown in Figure 4.2.1-1 (a collection of basic functional diagrams is provided in an annex to the standard so that the designer can adapt them for the specific project);
- a draft system layout, showing the possible location of the required equipment;
- a system operation sequence (operation and control rationale);
- an estimation of the expected system performance and cost.

The design concept shall:

- confirm that the designed system can be realised;
- confirm that the energy performance targets can be achieved;
- provide a cost estimation of the project;
- support a go/no-go decision to proceed with the detailed design.

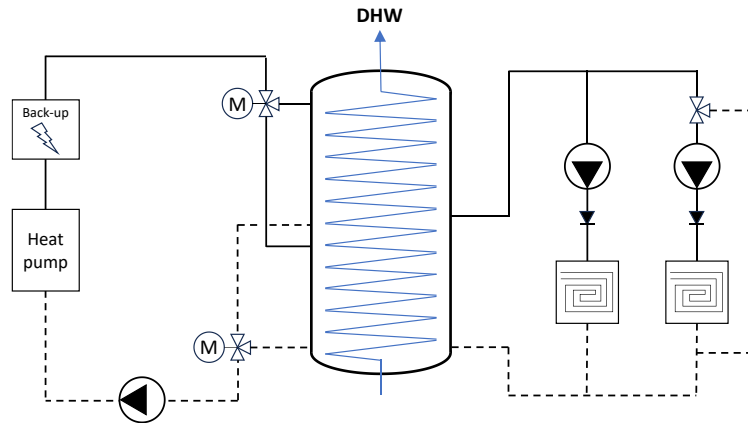

Figure 4.2.1-1. Sample basic functional diagram

The preliminary design is an important step for renovations, where a combustion boiler is replaced by a heat pump, which is expected to be the most common case in the coming years. Heat pumps do not provide a simple one-to-one replacement for boilers: upgrades of existing building enclosures and/or terminal emitters may be needed to install a heat pump successfully.

If the design concept is approved, then the design workflow continues with the detailed design, where all design issues are addressed systematically.

Sometimes, several sizing procedure alternatives are presented because of the variety of possible boundary conditions and design approaches across Europe. An example is the sizing of the heat pump itself, that requires considering at least three issues, with possible alternatives in their evaluation (see Figure 4.2.1-2):

- The starting point is the required power output under design conditions, that is the building enclosure requirement. Several alternatives are proposed:
 - heat load, which is the traditional approach to sizing heating systems but leads to over-sizing;
 - new approaches, based on energy performance calculation (either monthly or hourly) or measured energy use for existing buildings. This provides a more accurate tailored sizing.
- The next step is considering the availability and intended use of a back-up generator. Here, too, several alternatives are provided. The sizing criterion can be either a desired bivalence temperature or a desired energy needs coverage, and the control option can be alternate or simultaneous operation.
- Finally, the allowed daily operation time and schedule may be considered.
- Hourly methods based on EN ISO 52016-1 (CEN, 2017c) applied on a design day or week are also proposed. They allow to deal simultaneously with all previously mentioned issues and options.

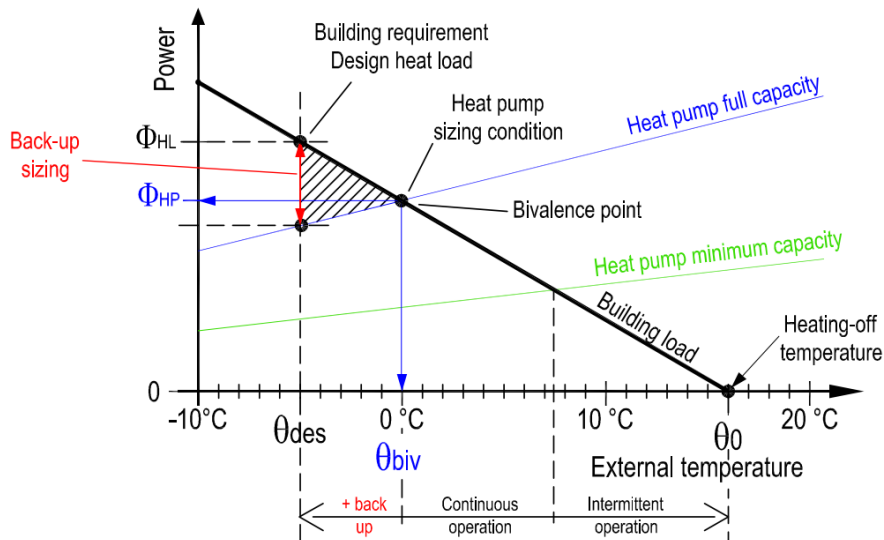

Figure 4.2.1-2. Graphical example of the bivalence point concept.

A new feature worth mentioning is the sizing of the domestic hot water storage volume, which is a basic concern, because of the limited available power of the heat pump and the intrinsically high power / low energy demand for domestic hot water service. There are two methods proposed (see Figure 4.2.1-3):

- a simple rough method based on the domestic hot water daily needs, similar to that in the accumulation method of the current standard: have a storage volume twice the average daily volume needs;
- a detailed method based on a design load curve according to EN 12831-3:2017 (CEN, 2017a), which is a comparison between the cumulated energy required during the day with a one-minute time interval and the system performance curve.

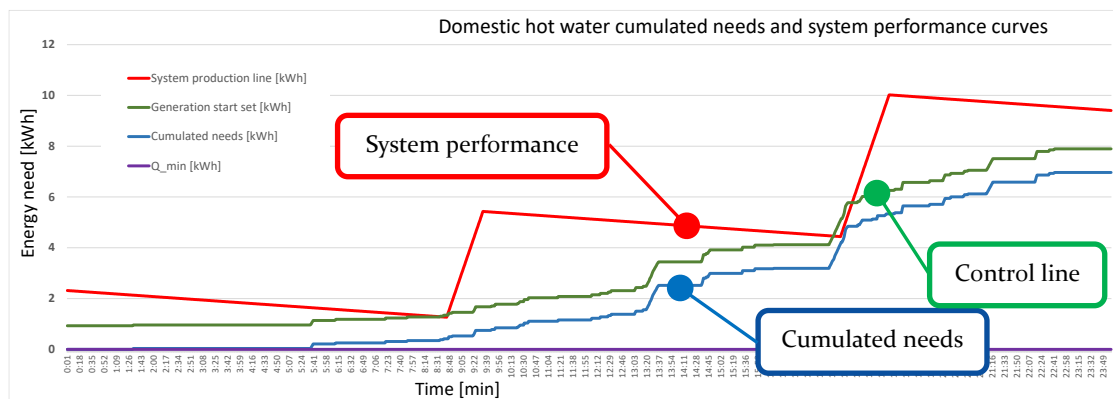

Figure 4.2.1-3. Comparison between load requirements and system capacity

The detailed procedure may provide a useful tool to size heat pump systems for domestic hot water in demanding non-residential contexts such as hotels. The sizing of a heat pump for space cooling is a new topic introduced in this revision. Until now, it has not been a routine task in northern and central Europe, whilst in southern Europe, cooling system sizing practices and methods still vary substantially. A basic simplified method taken from a Danish standard is presented to calculate the instantaneous peak cooling load. Gains at peak conditions are summed and the effect of heat accumulation in the internal structures is considered as a reduction in cooling load. This method needs localised climatic data about solar radiation depending on façade orientation. Other methods are mentioned, such as the hourly method presented in EN ISO 52016-1 (CEN, 2017c), clause 6.5.4.5, which is also applies to cooling system sizing.

4.2.1.1.4 Foreseen development

The new draft is under development and should be ready to undergo public review at the end of year 2024. Then one more year will be necessary for handling comments and to complete the formal vote procedure. If the process is smooth, the revised EN 15450 should be available at the end of 2025 or early 2026

4.2.1.2 VDI 4645 Heating systems with heat pumps in single and multi-family houses - Planning, construction, operation

VDI 4645 (VDI, 2023) deals with the steps necessary for the planning of heat pump systems in single and small multi-family (mainly two-family) residential buildings from the preliminary examination/concept preparation to the detailed planning. The scope includes only hydronic space heating and domestic hot water heating.

It is described that to achieve a high efficiency of the heat pump, the flow temperature in the space heating operation must be kept as low as possible. In the 4-pipe system, each primary circuit is operated at a system temperature required for the application. For this reason, it is said that different buffer storage systems are required for the space heating and the domestic hot water heating system, as shown in Figure 4.2.1-4. A figure showing the relationship between flow temperature and coefficient of performance (approximately linear relationship) is given.

The ways of sizing the storage tank volume for domestic hot water and for space heating water are described in 9.5.1.2 of VDI 4645 (VDI, 2023). For the sizing of the storage tank for domestic hot water, average tapping (draw) profiles for one-member, two-member and three member families are included in Annex J of VDI 4645.

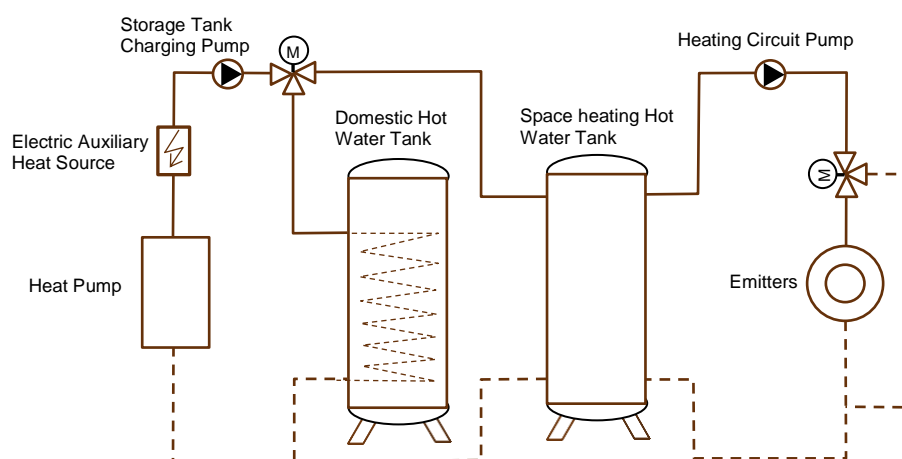

Figure 4.2.1-4 Typical configuration of heat pump systems for a detached house or two-family houses

Sizing of the heat pump is also described, taking into consideration the option of a supplemental heating source, such as an electric heater or a fossil fuel boiler.

Efficiency assessment of heat pumps is included in Annex G, where methods to calculate the seasonal coefficient of performance of the heat pump in bivalent heating operation (COP_H) and the seasonal COP of the bivalent heat pump in the domestic hot water heating system are described (Annex G). A method of cost estimation is by using the COP_H and the COP_W only (Annex H).

In Chapter 2, some guidance is provided on commissioning and how to set the control system. In this chapter, documentation and instruction for the user are also described. Items that are covered include:

Switching the system on and off, switching the heating circuits and domestic hot water heating on and off, changes in temperature, changes of time windows, and explanation of the indicators (controller and device displays, pressure and temperature indications).

Annex D is the overall checklist for concept and detailed planning of heat pump systems.

4.2.1.3 National application of European design guidelines in Denmark

4.2.1.3.1 National application of European design guidelines in Denmark

Scandinavia has always been at the forefront of renewable energy. Indeed, it was in Denmark and Sweden during the 1980s that the initial standards for heat pumps were established. In these early Nordic standards, the focus was on the requirements for the declaration of heat pumps, and a set of test requirements for the products were laid out. Today, these standards are crafted by a technical committee (TC) under the European Committee for Standardization (CEN), which represents shared European interests. Over recent years, standards have been developed that provide an accurate representation of the efficiency of heat pumps.

4.2.1.3.2 Relevant standards as a basis for Danish design guidelines

In Denmark, heat pumps must adhere to several standards, including EN14511, EN14825, EN16147, and EN12102.

1) EN14511 “Air conditioners, liquid chilling packages and heat pumps for space heating and cooling and process chillers, with electrically driven compressors (CEN - Comité Européen de Normalisation, 2018). It has four parts: 1) Terms and definitions, 2) Test conditions, 3) Test methods, 4) Requirements.

Heat pumps are becoming increasingly important in the context of sustainable and renewable energy solutions. Standards like EN14511 ensure these technologies deliver their promised performance and maintain safety, reliability, and environmental responsibility. As the demand for efficient heating and cooling solutions grows, adherence to such standards becomes crucial for manufacturers, installers, and end-users alike.

Key Aspects of EN14511:

Scope: The standard applies to both air-to-air and liquid-to-air air conditioners and heat pumps, liquid chilling packages, and dehumidifiers. It encompasses both factory-made products and those assembled on-site.

Performance Ratings: One of the primary objectives of the EN14511 (CEN, 2018) is to define the performance rating of these devices in terms of capacity and efficiency under various operating conditions. This aids in benchmarking and ensuring the product's capability matches its specifications.

Testing Requirements: The standard lays down specific testing methodologies and conditions for ensuring consistent and reliable results. These methodologies measure the efficiency and performance of heat pumps in a range of conditions – for instance, different temperatures and pressures.

Safety and Environmental Concerns: While the focus is on performance, the standard also touches upon certain safety and environmental concerns, ensuring that the heat pumps do not pose risks to users and are environmentally friendly.

Interoperability and Integration: Given the diverse applications of heat pumps – from domestic settings to larger commercial environments – the EN14511 (CEN, 2018) ensures products can be integrated seamlessly into various systems and infrastructures.

2) EN14825 “Air conditioners, liquid chilling packages and heat pumps, with electrically driven compressors, for space heating and cooling - Testing and rating at part load conditions and calculation of seasonal performance”

In an era where energy efficiency and sustainability are paramount, the EN14825 (BSI, 2022) standard is crucial. It ensures that heat pumps and related products are not just efficient under lab conditions but deliver consistent performance throughout their operational life, reflecting the actual European climate conditions. Manufacturers and consumers alike benefit from this standard, which provides a clear benchmark for product performance and efficiency.

Key Aspects of EN14825:

Scope: The EN14825 standard applies to all types of air conditioners, heat pumps, and chillers, including both the ducted and ductless varieties, regardless of their source of energy or the type of energy used (e.g., electricity or gas).

Seasonal Performance Metrics: One of the standout features of EN14825 is its emphasis on seasonal performance. Instead of merely evaluating a device's performance under standardised test conditions, it considers variations in climatic conditions throughout the year. This provides a measure of the unit's efficiency and effectiveness over the entire heating or cooling season.

EN 14825 is intended to support the application of the European Eco-design and Eco-labelling directive. It provides a method for calculating a “seasonal” performance (SCOP and SEER) under an assumed operating condition. It complements EN 14511 (CEN, 2018) in defining part load test conditions suitable for providing the data for the calculation of the SCOP and SEER.

Testing Protocols: EN14825 details the test methods to determine and verify the seasonal performance coefficients, ensuring that manufacturers and testers have clear and consistent guidelines to follow.

Classification and Ratings: The standard provides a basis for classifying and rating the efficiency of devices. This classification helps consumers, installers, and policymakers make informed decisions about the products in terms of their environmental impact and potential energy savings.

Supporting Information: Apart from technical specifications and testing methodologies, EN14825 also requires that supplementary information, like user manuals and product labels, be provided with the products. These details help users understand the optimal usage conditions and maintenance requirements.

Integration with Other Standards: EN14825 works in conjunction with other standards, such as EN14511, to provide a comprehensive view of the performance of heat pumps and related devices.

3) EN16147 (CEN, 2022).

As domestic hot water production is a significant contributor to household energy consumption, heat pumps in this category can play a vital role in enhancing energy efficiency. The EN16147 standard is thus essential as it ensures that these heat pumps are effective in their primary function and energy-efficient, safe, and environmentally responsible. Adherence to this standard is crucial for manufacturers, ensuring their products meet high-quality benchmarks, and it provides consumers with a reliable measure of a product's performance and safety.

Key Aspects of EN16147: “Heat pumps with electrical driven compressors- testing. Performance rating and requirements for marking of domestic hot water units”

This standard specifies methods for testing, rating of performance and calculation of water heating energy efficiency of air/water, brine/water, water/water and direct exchange/water heat pump water heaters and heat pump combination heaters with electrically driven compressors and connected to or including a domestic hot water storage tank for domestic hot water production. This standard includes only the testing procedure for the domestic hot water production of the heat pump system. This document only applies to water heaters which are supplied in a package of heat pump and a storage tank.

Scope: EN16147 is specifically geared towards heat pumps designed for producing domestic hot water. This includes units that are monobloc, split, or with multiple compressors and can be either factory-made or assembled on-site.

Performance Metrics: The primary aim of this standard is to set the performance rating of the heat pumps in terms of their capacity and efficiency. It evaluates the coefficient of performance (COP) and energy efficiency, ensuring the product meets its specified performance metrics.

Testing Conditions: EN16147 establishes standardised testing conditions, which include specific ambient and load conditions. This ensures that all products are tested under consistent conditions, allowing for accurate comparisons between different units.

Safety and Environmental Factors: Beyond performance metrics, the standard also addresses certain safety and environmental considerations, ensuring that the heat pumps are safe to operate and do not harm the environment. This can include factors like refrigerant type and emissions.

Product Information: Manufacturers are required to provide specific information about their products, ensuring transparency for the end-users. This can include data about the product's performance, its optimal operating conditions, maintenance requirements, and more.

Interoperability: Given the various configurations and applications of heat pumps for domestic hot water production, EN16147 ensures such products can be integrated smoothly into different domestic setups without hindrance

4) EN12102

EN12102 (CEN, 2020) plays a critical role in ensuring that the acoustic emissions of heat pumps and related devices are within acceptable limits, promoting user comfort and environmental well-being. This standard is invaluable for manufacturers aiming to design quieter, more efficient devices, and for consumers seeking products that will not disrupt their living or working environments.

Key Aspects of DS/EN12102:

Standardised Procedure: The standard provides a uniform procedure for accurately determining the sound power levels of the specified devices. Such standardisation ensures that all measurements are consistent and comparable across different devices and manufacturers.

Importance of Acoustic Measurements: Sound power levels are crucial for assessing the potential noise pollution a device might cause. Noise can affect the comfort and well-being of inhabitants and neighbours. For commercial applications, excessive noise can also impact worker productivity and comfort.

Testing Conditions: The standard will probably stipulate the conditions under which the measurements should be taken, including ambient conditions, device operational state, and the environment in which the test is conducted.

Reporting and Declaration: Manufacturers are expected to report their findings according to this standard, providing potential buyers and users with a clear understanding of the acoustic profile of the product.

Supporting Sustainable Design: As more emphasis is placed on creating sustainable and comfortable living and working environments, the noise emitted by essential HVAC equipment becomes a pivotal consideration. EN12102 supports this by providing clear metrics for airborne noise evaluation.

4.2.1.3.3 General Heat Pump Design Guidelines for Danish Buildings

The general design guidelines for heat pump systems in buildings, considering Denmark's context:

1. Selection of Heat Pump Type: Depending on the source of heat available, there are different types of heat pumps to choose from:
 - Air-to-Water/Air-to-Air Heat Pumps: These extract heat from the ambient air.
 - Ground Source Heat Pumps (GSHP): These use heat from the ground via boreholes or

horizontal loops.

- Water Source Heat Pumps: Extract heat from nearby water sources, like lakes or rivers.
2. Sizing of Heat Pump: The heat pump should be correctly sized according to the heating demand of the building. Over-sizing can lead to more frequent start-stops, reducing the efficiency and life of the heat pump.
 3. Integration with Existing Systems: In many renovation cases in Denmark, heat pumps are integrated with existing heating systems, such as district heating or gas boilers, to ensure maximum efficiency and reliability.
 4. Temperature Levels: Heat pumps are most efficient when supplying low-temperature heating systems, such as underfloor heating. For older buildings with radiators designed for higher temperature supply, ensure that the radiators are large enough or consider integrating with other systems.
 5. Insulation: Ensure the building envelope is properly insulated to reduce the heating demand. This is important in Denmark's cold climate to ensure the efficiency of the heat pump system.
 6. Controls and Monitoring: Intelligent controls can adapt the operation of the heat pump based on the outdoor temperature, occupancy patterns, and other variables to ensure maximum efficiency.
 7. Maintenance: Regular maintenance and monitoring can ensure the system operates efficiently over its lifespan.
 8. Integration with Renewables: Given Denmark's focus on wind energy, integrating heat pumps with renewable sources like wind or solar PV can further reduce carbon footprints.
 9. Legislation and Incentives: Keep in mind any governmental regulations, incentives, or grants that are available to encourage the adoption of heat pumps. Denmark has often offered incentives for sustainable building practices and renewable energy installations.
 10. Noise and Aesthetics: Especially for air-source heat pumps, consider the noise levels and aesthetics, ensuring they do not pose disturbances to inhabitants or neighbours.
 11. Hybrid Systems: Consider hybrid systems that combine heat pumps with boilers or other heating systems to ensure continuous heating during extreme cold spells when the efficiency of heat pumps might decrease.
 12. Training and Awareness: Make sure that the occupants and building managers understand the operation of the heat pump system, which can be crucial for its optimal functioning.

For the most up-to-date guidelines and specific standards related to Denmark, it would be best to refer to the Danish Energy Agency or relevant local building codes. Also, professional associations related to HVAC and building systems in Denmark might have detailed, updated guidelines and best practices for the design and installation of heat pump systems.

In Denmark, the installation and design of heat pump systems in buildings are regulated and guided by specific national standards (European standards published by CEN and according to CEN rules taken over by Danish Standards) and building codes. The primary standards and regulations relating to heat pump installations in Denmark are:

1. EN 15450: Heating systems in buildings - Design of heat pump heating systems. This standard specifies the requirements for the design of heat pump heating systems in buildings (BRI Japan, 2010).
2. EN 14825: Air conditioners, liquid chilling packages and heat pumps for space heating and cooling and process chillers, with electrically driven compressors - Testing and rating at part load conditions and calculation of seasonal performance.
3. Building Regulations (BR23): These are the general building regulations in Denmark which, among other things, include requirements for the energy performance of buildings, which heat pumps can play a role in achieving.
4. Danish Energy Agency Guidelines (Danish Energy Agency, 2018): The Danish Energy Agency

provides guidelines and requirements for various energy technologies, including heat pumps, to ensure efficient and sustainable use.

Besides the national standards and regulations, various industry associations in Denmark, such as the Danish Heat Pump Association (DHPA), may offer additional guidelines and best practices.

1. EN 15450 - Heating systems in buildings - Design of heat pump heating systems:
 - Scope: This standard is specific to heat pump heating systems in buildings. It sets the requirements for the design, dimensioning, installation, and control of heating systems with heat pumps, in combination with any other heat source if used.
 - Key Elements:
 - Determination of building heat losses to size the heat pump accurately.
 - Guidelines for the selection of the heat source (air, water, or ground) and the related necessary components.
 - Provisions for integrating with other heating systems.
 - Control and regulation guidelines for maintaining user comfort and achieving high energy efficiency.
 - Considerations for domestic hot water production using heat pumps.
2. EN 14825 - Air conditioners, liquid chilling packages and heat pumps for space heating and cooling and process chillers, with electrically driven compressors:
 - Scope: This standard deals with the testing and rating of air conditioners, liquid chilling packages, and heat pumps used for both space heating and cooling.
 - Key Elements:
 - Specifies test conditions for full load and part-load performance and seasonal performance.
 - Provides methods for determining the capacity, power consumption, and efficiency of these systems.
 - Sets forth standard rating conditions to make a comparison between different products easier for consumers.
 - Addresses different climate conditions, ensuring that the systems are tested for diverse operational challenges.
3. Building Regulations (BR23):
 - Scope: The Building Regulations cover all aspects of building construction in Denmark, from energy to indoor climate and fire safety. The energy provisions in BR23 ("Danish building regulations - codes (BR23)," 2023) are relevant for heat pumps.
 - Key Elements:
 - Specifies minimum energy performance requirements for new buildings and renovations.
 - Provides methodologies for calculating a building's energy needs.
 - Promotes energy-efficient technologies and solutions, such as heat pumps.
 - Emphasises the integration of renewable energy sources, which includes the operation of heat pumps in tandem with renewable energy.
 - Addresses ventilation, insulation, and airtightness standards that impact the heating and cooling demands and thus influence the design and operation of heat pump systems.
4. Danish Energy Agency Guidelines:
 - Scope: The Danish Energy Agency offers various guidelines related to energy use, including those concerning heat pumps.
 - Key Elements:

- Promotion of efficient and sustainable energy technologies.
- Information on subsidies or incentives for installing heat pumps and other renewable technologies.
- Best practice guidelines and case studies for efficient implementation.
- Reporting and documentation requirements for different energy solutions.

The details provided above give a broad overview, but the actual standards provide specific technical criteria, methodologies, and guidelines that need to be followed for compliance.

4.2.2 Canadian codes and practices

Heat pump installation practices are taught in Canada through the provincial and federally recognised “Red Seal” program’s refrigeration and air conditioning mechanic designation (Red Seal Program, 2024). Design practices are taught through the Heating, Refrigeration and Air Conditioning Institute’s (HRAI) courses, with the Residential Air Systems Design (RASD) course and Residential Heat Loss and Heat Gain (RHLHG) courses being directly relevant to heat pump equipment sizing and selection. Regional associations such as the Thermal Environment Comfort Association (TECA) in British Columbia, Home Performance Stakeholders Council (HPSC) in British Columbia as well as others also have regional teaching workshops and teaching materials.

Relevant codes and standards related to heat pump installation and design would include:

- For air source heat pumps: CSA C273.5:11 (R2020) “Installation of air source heat pumps and air conditioners”
- For ground source heat pumps: CAN/CSA-C448 SERIES-13 “Design and installation of earth energy systems”

Additionally, the federal government of Canada undertakes industry design and installation support training through Natural Resources Canada, CanmetENERGY Local Energy Efficiency Partnerships (LEEP) program. A series of videos aimed at contractors and the design community specific to residential heat pump retrofits are hosted on the LEEP website (Government of Canada, 2024a). Natural Resources Canada’s CanmetENERGY also produced and maintains an Air Source Heat Pump Sizing and Selection Toolkit (Government of Canada 2024b) aimed at heat pump distributors, contractors and designers, comprising a Step-by-Step Sizing and Selection procedure (the Guide), an Addendum of worked examples, training video, an Excel-based Tool and forthcoming online App. Building code adoption, installation and design practices are released federally in Canada by the National Research Council of Canada and adopted as is, or with modifications, at the discretion of provinces within Canada. Codes overseen by the National Research Council of relevance to heat pump design and installation include:

- The National Building Code of Canada (Government of Canada 2020a)
- The National Energy Code of Canada for Buildings (Government of Canada 2020b)
- The National Plumbing Code of Canada (Government of Canada 2020c)

Provisions within the National Electrical Code also have implications on the design and installation of heat pumps. The Canadian Electrical Code (CSA Group 2024a) is overseen by the Canadian Standards Association.

4.2.2.1 Toolkit for air source heat pump sizing and selection

Background

Natural Resources Canada developed a package of materials for air source heat pump (ASHP) sizing and selection (Government of Canada 2024b), intended for use by mechanical system designers and renovation contractors. The materials were designed to assist these individuals with sizing and selecting ASHPs for Canadian climates in both new and existing (retrofit) residential applications.

Scope

The Toolkit focuses on air source heat pumps (ASHPs) for space heating and/or cooling applications. The Toolkit covers the following applications of ASHPs:

- New home (or major new addition) installations.
- Full heating system replacement where existing HVAC equipment is removed.
- Add-on ASHP applications to displace heating energy or provide supplemental heating where existing heating equipment remains functional.

This Toolkit covers the following technologies:

- Ducted and ductless ASHPs
- Single-zone and multi-zone centrally ducted ASHPs
- Single-zone and multi-zone ductless mini-split ASHPs
- Single-zone and multi-zone ducted mini-split ASHPs
- Single-stage ASHPs
- Staged and variable-capacity ASHPs
- Cold-climate ASHPs.

Exclusions:

- Installation best practices and requirements are outside the scope of this guide.

Overview of the Air-Source Heat Pump Sizing and Selection Process

An overview of the ASHP sizing and selection process is shown graphically in Figure 4.2.2-1.

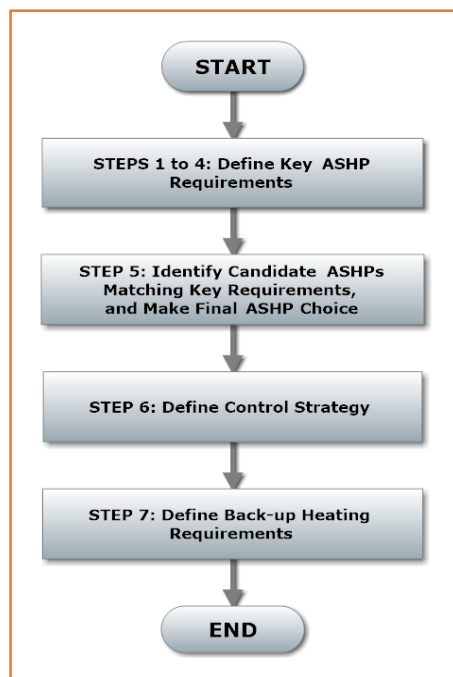

Figure 4.2.2-1. Overview of the ASHP Selection and Sizing Process

The process comprises seven steps, which can be grouped into four major parts:

- I. Define key ASHP requirements (STEPS 1 to 4);
 - Define ASHP Configuration.
 - If required, choose mini-split indoor unit types.
 - Determine heating and cooling loads.
 - Determine sizing approach and ASHP target capacity requirements.
- II. Identify candidate ASHPs matching key requirements and make final ASHP choice (STEP5);
- III. Define system control strategy (STEP 6); and,
- IV. Define backup heating requirements (STEP 7).

Components of the Toolkit

The Toolkit comprises:

- ASHP Sizing and Selection Guide (referred to as “the Guide”) and ASHP Key Specifications Summary Worksheet (included in the Guide as Appendix B, see Figure 4.2.2-1 & 4.2.2-2);
- ASHP Sizing and Selection Tool: an electronic representation of the ASHP Sizing and Selection Guide. The tool interactively guides users in applying the step-by-step process described in the Guide while providing additional charting and performance analysis features;
- Addendum of worked examples provides case studies of the Guide used to select centrally ducted or ductless mini-split ASHPs for various installation scenarios.

Users can complete the guide process using one or more of these components. Short descriptions of each are provided below.

ASHP Sizing and Selection Guide

This seven-step guide provides sizing and selection instructions, and information on various options for both centrally-ducted and mini-split ASHPs.

- Complete each step of the guide in the order shown to size and select an ASHP for a specific application.
 - Each STEP provides the user with 3 to 4 options.
 - Short descriptions of each option help users select which “best fits” specific application requirements.
 - Chosen options are recorded on the ASHP Key Specifications Summary Worksheet (see Figure 4.2.2-2).
- Use the information recorded in Steps 1 to 4 to identify a short list of commercially available ASHP models suitable for the specific application.
- Final ASHP selection can be based on such items as:
 - Staging or modulation capabilities,
 - Efficiency ratings,
 - Noise ratings, and
 - Equipment cost.
- In the final two steps, define:
 - The ASHP system control strategy, and
 - The backup heating requirements.

ASHP Key Specifications Summary Worksheet

The **ASHP Key Specifications Summary Worksheet** can be used in one of two ways:

- Together with the **ASHP Guide** as a summary sheet that records decisions made while working through the seven steps using the full Guide documentation; or,
- As a stand-alone worksheet, experienced users can complete sizing and select an ASHP, referring to the full guide documentation only when additional information is required.

ASHP Sizing and Selection Tool

This Excel-based tool examines the Guide steps to assist designers or contractors in sizing and selecting air-source heat pumps (ASHP) in Canadian climates.

The ASHP sizing and selection tool will perform various calculations and charting functions that can help size and select ASHPs. These include, among others:

- Plotting of heating load lines and estimating the target output capacity of ASHP equipment needed for an application based on:
 - load values entered, and
 - sizing approach selected.
- Plotting of ASHP output characteristics versus outdoor temperature and estimating thermal balance point temperatures (t-BPTs) for up to four candidate ASHPs for an application.
- Estimating the annual fraction of total space heating load provided by the different candidate

ASHPs above their t-BPTs to help with the final selection.

- Calculating the minimum backup heating requirement for the application.
- For dual-fuel (“hybrid”) applications, calculating the “economic cut-off temperature” for the ASHP based on:
 - local cost of electricity and fuel, and
 - the efficiency characteristics of the ASHP and the backup heating system.

Project or Client Name: _____ Date Completed: _____
 COMPLETION INSTRUCTIONS: Select Required Option(s) in each STEP. Provide information in shaded boxes as necessary

Key ASHP Requirements	Option A	Option B	Option C	Option D	NOTES
1 Define ASHP Configuration	1A: Centrally Ducted:	1B: Ductless Mini-split, Single-Zone No. of outdoor units: _____	1C: Ductless Mini-split, Multi-Zone No. of outdoor units: _____		<input type="checkbox"/> New Home Install <input type="checkbox"/> Full System Replacement <input type="checkbox"/> Add-on ASHP
2 Choose Mini-split Indoor Unit Type(s)	2A: Wall-Mounted: No. of units required: _____	2B: Floor Mounted: No. of units required: _____	2C: Ceiling Mounted: No. of units required: _____	2D: Ducted (concealed): No. of units required: _____	NOTE: ONLY COMPLETE STEP 2 if using Option 1B or 1C
3 Determine Design Heating Load (DHL) and Design Cooling Load (DCL) Estimates	F280-12 Design values DHL: _____ Btu/h DCL: _____ Btu/h	Energy Audit Report Estimates Reported DHL: _____ Btu/h Adjusted DHL: _____ Btu/h Reported DCL: _____ Btu/h Adjusted DCL: _____ Btu/h	Energy Model Estimates of Design Loads DHL: _____ Btu/h DCL: _____ Btu/h	Existing Equipment Capacities: Heating (output): _____ Btu/h DHL estimate: _____ Btu/h Cooling (output): _____ Btu/h DCL estimate: _____ Btu/h	F280 Design temperatures for house location Heating: _____ °F Cooling: _____ °F
4 Determine Sizing Approach and Capacity Requirements of ASHP	4A: Emphasis on Cooling Target: 80% DCL: _____ Btu/h to 125% DCL: _____ Btu/h Single-stage: Match output to target Multi-stage: Match maximum output to target	4B: Balanced Heating & Cooling Target: 80% DCL: _____ Btu/h to 125% DCL: _____ Btu/h Single-stage: Match output to high end of target Multi-stage: Match minimum output to target	4C: Emphasis on Heating Heating Load at: 17°F: _____ Btu/h	4D: Sized on Design Heating Load Target: DHL: _____ Btu/h at _____ °F (Design Temperature)	For FULL SYSTEM Replacements - Maximum Airflow capacity of existing ducting: _____ CFM
Identify & Select ASHP	Candidate #1	Candidate #2	Candidate #3	Candidate #4	Final Choice: _____
5 Identify candidate ASHP models matching Key Requirements	Model #: _____ Stages: _____; Cut-off: _____ °F Nominal Cap: _____ Heat-output: _____ Btu/h at 17°F <input type="checkbox"/> , or at _____ °F Cool-output at 95°F: _____ Btu/h	Model #: _____ Stages: _____; Cut-off: _____ °F Nominal Cap: _____ Heat-output: _____ Btu/h at 17°F <input type="checkbox"/> , or at _____ °F Cool-output at 95°F: _____ Btu/h	Model #: _____ Stages: _____; Cut-off: _____ °F Nominal Cap: _____ Heat-output: _____ Btu/h at 17°F <input type="checkbox"/> , or at _____ °F Cool-output at 95°F: _____ Btu/h	Model #: _____ Stages: _____; Cut-off: _____ °F Nominal Cap: _____ Heat-output: _____ Btu/h at 17°F <input type="checkbox"/> , or at _____ °F Cool-output at 95°F: _____ Btu/h	Heat-output: _____ Btu/h at 17°F <input type="checkbox"/> , or at _____ °F Low Temp. Cut-off: _____ °F Cooling at design: _____ Btu/h BP Temperature: _____ °F %Total Heating above BPT: _____ % of total
Control Strategy	Option A (ASHP cut-off above design T)	Option B (ASHP cut-off below design T)	Option C (ASHP cut-off below design T)		NOTES
6 Define Control Strategy	ASHP Cut-off Control required 6A1: Low-Temp cut-off at: _____ °F 6A2: Economic cut-off at: _____ °F	No ASHP Cut-off Control required 6B1: Heat pump may operate over full outdoor temperature range ASHP Cut-off Control required: 6B2: Economic cut-off at: _____ °F	No Backup Heat 6C: Heat pump is Sole Heat Source (No ASHP Cut-off Control required)		
Back-up Heating	Option A	Option B	Option C	Option D	NOTES
7 Define Backup Heating Requirements	7A - New required at > 100% DHL Minimum of: _____ Btu/h	7B - New required < 100% DHL Minimum of: _____ Btu/h	7C - No new Backup required (use existing heating system for backup heating)	7D - No Backup Required (ASHP output is greater than the design heating load at the design temperature)	NEW Backup Type: <input type="checkbox"/> Fuel: _____ <input type="checkbox"/> Electric: _____

Figure 4.2.2-2. ASHP key specification summary worksheet

Addendum to the ASHP Guide of Worked Examples

Worked examples have been completed for both centrally-ducted and ductless mini-split ASHPs using various sizing and selection scenarios. These example cases illustrate how the guide process works and have been prepared to help users better understand the various decision steps when selecting ASHPs for different applications.

4.2.2.2 CSA SPE-17:23 HVAC guide for Part 9 homes

With the permission of Canadian Standards Association, (operating as “CSA Group”), the material described below is reproduced from CSA Group standard CSA SPE-17:23, HVAC guide for Part 9 homes (CSA, 2023). This material is not the complete and official position of CSA Group on the referenced subject, which is represented solely by the Standard in its entirety. While use of the material has been authorised, CSA Group is not responsible for the way the data is presented, nor for any representations and interpretations. No further reproduction is permitted. For more information or to purchase standard(s) from CSA Group see (CSA, 2024b).

Background

The ultimate performance of the heating, ventilation, and air conditioning (HVAC) system in a residential Part 9 home depends upon proper design, installation, and commissioning, with each of these components being equally critical to delivering the designed efficiency of the equipment itself.

In new construction, adequate planning and upfront integrated design of HVAC systems in new, low-rise residential buildings is not common practice, resulting in systems not being fully optimised for performance.

Research published by the American Council for an Energy-Efficient Economy (ACEEE) shows that 50 to 70% of HVAC systems are improperly installed, causing them to be 10 to 50% less efficient than if they received quality design, specification, and installation (Mowris and Jones, 2008).

HVAC has been the single largest source of new home complaints by their owners. Design, poor quality systems, and inadequate installations have all been found to be the problem in different parts of Canada (see (Canadians for Properly Built Homes, 2024) for further information).

Expanding on this, Canada's Part 9 residential building industry is going through a significant period of change where builders, architects/designers, engineers, trades, manufacturers, authority having jurisdictions (AHJ), and other industry stakeholders are adapting to increasing market demand for enhanced performance in homes. This is characterised by a transition to performance-based energy codes or standards like the BC Energy Step Code (Energy StepCode, 2018), Zero Carbon Step Code (Energy StepCode, 2020), or the Passive House standard, as well as a growing regulatory focus on decarbonisation.

The combination of market and regulatory conditions and rapidly evolving technologies creates an opportunity for the residential design and construction community to improve significantly overall indoor comfort, improve home performance, and enhanced resiliency and health outcomes at the same time. The risk is that an integrated sequence of HVAC design, sizing, installation, and commissioning could be overlooked, or not fully considered, as residential buildings seek to achieve low-energy/low-carbon performance targets, resulting in the following:

a) Increased costs — Improperly sized equipment costs more to install and operate. It increases maintenance and repairs and shortens the life cycle of equipment.

b) Poor comfort — Inadequate approaches to equipment selection, HVAC design, and installation results in HVAC “short-cycling” and poor performance (e.g., uneven temperatures, equipment noise).

c) Performance liabilities — Incorrectly designed HVAC systems are more likely to undermine a homeowners' sense of satisfaction and tarnish builder reputations while also creating potential liabilities and warranty claims.

d) Home aesthetics — Larger or poorly designed HVAC systems can incorporate equipment and duct requirements that compromise living spaces with larger than needed bulkheads and chases.

To address these issues, a more sophisticated approach is needed to deal with the knowledge gap in mechanical HVAC systems for new Part 9 buildings, helping to ensure that both functional and performance-based objectives and targets are met.

Current practices

Within current building industry practices, there is a lack of design stage planning for the HVAC systems, which limits design strategies and equipment choices, creating increased costs and poor operational performance. Inadequate consideration of proper design and installation of mechanical systems is characterised by:

a) “rule of thumb” approach to heat loss and heat gain calculations;

b) lack of upfront coordination with builder and architect in the design phase of the building design process.

c) absence of HVAC designs to guide installations or numerous opinions that vary on the HVAC design, none of which are supported by calculations and technical engineering;

d) lack of consistent and verifiable standards of practice within the HVAC industry; and

e) incomplete performance verification through commissioning to test the installed systems and document that HVAC equipment is operating to the design intent and meeting performance targets.

Enhanced practices

A better approach starts with integrated and coordinated design between builders, architects, building designers, HVAC designers, and contractors, focusing specifically on optimising overall HVAC system performance. Collaboration between designers, builders, and trades, as well as use of CSA F280 load calculations, are foundational elements of this approach. These practices help builders respond to increased energy and greenhouse gas (GHG) emission performance objectives, integrated with housing form, style, and construction methods. Enhanced practices include these essential elements:

- a) CSA F280 compliant load calculations to inform equipment sizing and selection;
- b) pre-construction integrated Design Process, coordinating with builders, architects, and clients to establish an HVAC strategy and design;
- c) a clearly articulated expectation of installation standards of practice; and
- d) performance verification, including on-site review, once the equipment is installed with commissioning results documented and verified to demonstrate optimised performance.

Evolving practices

Going forward, adaptation and change will be a constant for the construction industry, particularly with energy performance requirements in national and provincial building codes, eventually moving toward a net zero-ready standard. To meet these requirements, evolving HVAC industry practices may include:

- a) improved compliance and verification through more standardised permitting requirements by the AHJ (Authority Having Jurisdiction);
- b) additional inspection processes for consumer protection that verify HVAC system performance intentions are being met; and
- c) increased trade coordination and wider adoption of performance testing methodologies to confirm design/construction objectives are achieved (e.g., mid-stage blower door testing to confirm air tightness metrics).

Objectives

CSA SPE-17:23 (CSA, 2023) assists the building industry with identification of standards of practice that are designed to deliver HVAC systems that provide enhanced comfort, improved energy-efficiency, and ultimately achieve the performance expectations of builders, architect/designers, and homeowners alike. Overall objectives for CSA SPE-17:23 are:

- a) increasing building industry awareness on how an integrated/coordinated design process can help deliver efficient HVAC systems and better home performance;
- b) presenting best practices for HVAC design, equipment sizing, selection, installation, and performance verification of HVAC systems that can be readily applied by builders.
- c) communicating the options, opportunities, and limitations of various HVAC equipment in a fuel-neutral manner, to meet performance-based code requirements and support decarbonisation objectives; and
- d) building familiarity and confidence in more sophisticated building practices and HVAC technologies.

Audience

Audiences for CSA SPE-17:23 include:

- a) builders and developers;
- b) architect/designers;
- c) building officials;
- d) HVAC designers and HVAC contractors;
- e) energy advisors;
- f) utilities; and
- g) homeowners.

Scope

CSA SPE-17:23 highlights the benefits of best practices in proper design, sizing, installation, and commissioning for HVAC systems with a focus on practical information for building industry

practitioners to apply knowledge from the Guide to support new construction and major renovation projects. CSA SPE-17:23 also provides useful industry resources, supporting tools, and technical information.

CSA SPE-17:23 may be used as a technical reference document for Part 9 new residential buildings, incorporating illustrations, resources, and tools to assist with knowledge transfer and application. It has also guided collaboration between the builders, designers, tradespersons, and suppliers with respect to integration of sizing, design, installation, and performance verification.

4.2.3 US

4.2.3.1 ACCA manuals

4.2.3.1.1 Background

The Air Conditioning Contractors of America (ACCA) is an HVAC industry association that has published accredited and non-accredited procedures for residential and commercial HVAC equipment design and installation, and related services, since the 1970s. The design manuals for heat pumps include ANSI/ACCA 2 Manual J (2016) - Residential Load Calculation (8th Edition), ANSI/ACCA 3 Manual S (2014) - Residential Equipment Selection, and ANSI/ACCA 1 Manual D (2016) - Residential Duct Systems (where applicable, when ducted air distribution systems are used). Several other guides focus on specific skills and services related to residential HVAC).

4.2.3.1.2 Manual J – load calculations

Manual J is a procedure for calculating heating and cooling building and room loads under outdoor design conditions, and Manual S is a procedure for selecting appropriate heating and cooling equipment for a building, based on the results of Manual J calculations. Manual J and Manual S are the most frequently used and are both cited by reference in residential codes (model codes by the International Codes Council, which are adopted into regulation individually by most of US states and some cities or other jurisdictions) for many years as a code requirement for residential building construction. Neither Manual J, Manual S, nor Manual D is specific to heat pumps, but each includes general requirements for the most common types of residential cooling and heating systems.

Heating and Cooling Performance for Opaque Panels
U-Values and Group Numbers or CLTD Values

Construction Number 13 Block Walls and Partitions						
6, 8, 10 or 12 Inch block, any exterior finish (except 13AA = none and 13A = stucco, siding or brick), plus interior finish (except 13AA) Exterior finish code: s = stucco or siding; b = brick Core condition code: oc = open core; fc = filled core Framing code: w = wood, m = metal (studs 16 Inches on center, 75% cavity, 25% framing) Reference Area = Gross Wall Area - Area of Window and Door Openings						
Construction Number	Insulation R-Values	Description of Construction	Block Core	U-Value with Wood Studs	U-Value with Metal Studs	Group Number
13BA — Framing with R-11 In 2 x 4 Stud Cavity, No Board Insulation, No Exterior Finish, Open or Filled Core, Plus Interior Finish						
13BA-0oc w/m 13BA-0fcw/m	Cavity: R-11 Board: None	Block, no exterior finish, R-11 in stud cavity, open or filled core, plus interior finish	Open Filled	0.103 0.088	0.131 0.108	H H
13BB — Framing with R-11 In 2 x 4 Stud Cavity, No Board Insulation, Any Exterior Finish, Open or Filled Core, Plus Interior Finish						
13BB-0oc w/m 13BB-0fcw/m	Cavity: R-11 Board: None	Block, any exterior finish, R-11 in stud cavity, open or filled core, plus interior finish	Open Filled	0.088 0.077	0.109 0.093	H H
13B — Framing with R-11 In 2 x 4 Stud Cavity Plus Board Insulation; Any Exterior Finish, Open or Filled Core, Plus Interior Finish						
13B-2oc w/m 13B-2fc w/m	Cavity: R-11 Board: R-2	Block, any exterior finish, R-11 stud cavity, R-2 board, open or filled core, interior finish	Open Filled	0.080 0.071	0.097 0.084	I I
13B-3oc w/m 13B-3fc w/m	Cavity: R-11 Board: R-3	Block, any exterior finish, R-11 stud cavity, R-3 board, open or filled core, interior finish	Open Filled	0.074 0.066	0.089 0.078	I I
13B-4oc w/m 13B-4fc w/m	Cavity: R-11 Board: R-4	Block, any exterior finish, R-11 stud cavity, R-4 board, open or filled core, interior finish	Open Filled	0.069 0.062	0.082 0.072	I I
13B-5oc w/m 13B-5fc w/m	Cavity: R-11 Board: R-5	Block, any exterior finish, R-11 stud cavity, R-5 board, open or filled core, interior finish	Open Filled	0.064 0.058	0.075 0.067	J J

Figure 4.2.3-1. Example of construction type and thermal properties table from Manual J

Manual J provides detailed instructions on collecting thermal performance data and building dimensions, selecting appropriate indoor and outdoor design conditions, addressing air infiltration and solar gains, and includes extensive tables showing thermal performance values to use for building surfaces such as walls, windows, roofs, floors, etc. that use a wide range of construction and insulation approaches. An example is shown in Figure 4.2.3-1 (the standard includes nearly 200 pages of such tables). It also includes procedures to calculate the impacts of ventilation systems and duct losses and gains that may apply to existing or new buildings. Most users of Manual J use software, rather than manual calculations, to conduct the procedure, and ACCA has a process for approving software as being 'compliant' with the standard. The result is a report by room, by zone(s) if used, and for a whole building or dwelling, that states the heating, sensible cooling, and latent cooling loads at design conditions, that may be used for sizing and selecting equipment. The full edition of Manual J also includes large informative sections with examples, clarifying illustrations and commentary.

4.2.3.1.3 Manual S – Equipment selection

Manual S has detailed procedures for choosing based on capacity and other factors. The scope encompasses almost all types of residential HVAC equipment, including air conditioners, furnaces, boilers, most of which are not of interest in this report. However, a new version of Manual S has been approved by ANSI and is about to be published (at the time of this writing, it has yet to be available); the most notable changes are in how the procedure handles heat pump design.

Previous editions of Manual S (including 2014 cited above) only provided pathways for heat pump selection based on cooling capacity – with the limits of 90-115% of design cooling load for single - speed units, while allowing slightly larger over-sizing for cooling (120% to 130%) for other types of equipment, such as 2-speed, variable-capacity, or ground-source units. The focus is on avoiding oversizing so that humidity control is not compromised (and in very dry summer climates, a different approach is allowed). In this case, if the heating capacity is not adequate to meet the heating load under design conditions, then auxiliary heat (typically electric resistance) is specified. Figure 4.2.3-2 shows an example of this; in this case, the heat pump would have inadequate capacity at outdoor temperatures

below about -1 °C, and at the design condition of -10 °C a minimum of 4 kW of backup heat would be needed to meet the heating load.

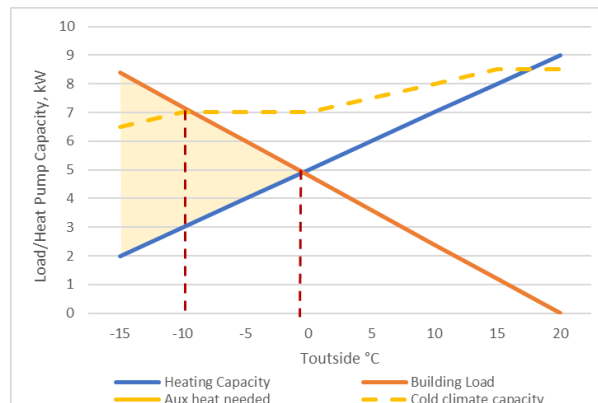

Figure 4.2.3-2. Traditional handling of low heating capacity using auxiliary heat, and cold-climate comparison

Many parts of the northern United States and most of Canada have heating design temperatures ranging from -15 °C to -25°C and, in some cases, even colder. The rapidly increasing interest in heat pumps for reducing carbon emissions, even in very cold climates, and the desire to reduce or eliminate the electric grid impact of resistance heating elements has led to a new alternative approach. There is now common availability of variable-speed systems with high heating capacities at cold temperatures (for example, the yellow dotted line in Figure 4.2.3-2), that may not require auxiliary heating at all. However, in cold and very cold climates, it is still quite common for cooling design loads to be significantly smaller than heating design loads, resulting in a conflict for designers who want to size heat pumps for full-load heating without violating the sizing requirements of Manual S and the building code.

The new edition of Manual S, *Residential Equipment Selection (3rd Edition, Version 1.01)* (ACCA - Air Conditioning Contractors of America, 2023), addresses these concerns by offering several explicit pathways to size heat pumps to meet 100% of the heating design load, while still maintaining control of summer humidity in climates where that is relevant. Table 4.2.3-1 summarises the most important requirements for two-speed and variable-speed units. Two-speed heat pumps allow more flexibility for sizing to heating loads, but still focus on maximum total cooling capacity with the expectation that supplemental heat will often be needed. All three variable-speed options specify explicitly that the unit meets 100% of the heating load, while addressing cooling and humidity control in various ways that can include dedicated dehumidification equipment or active dehumidification function built into the heat pump. Both two-speed and variable have limits to avoid unneeded oversizing, and all the variable-speed options explicitly negate the need for supplemental heat. Though supplemental heat is still allowed (for example, in a case where it may be needed for defrost operation), it is limited to a maximum of 5 kW.

Pros and cons

It is useful to have a consistent industry standard for load calculations to ensure accurate results and help promote and support proper equipment selection. And for sizing, it is a dramatic improvement to have a mechanism to allow for full heating load sizing in cold climates, which has been done in thousands if not tens of thousands of homes, but technically did not comply with building codes.

The most significant drawback of the load calculation procedure, Manual J is that most residential proposals are made by salespeople, and most often they either do not bother with the calculations or do not trust the results. Despite the clear statements in Manual J to take credit aggressively for all energy efficiency features, there are strong tendencies for users to increase the calculated loads to represent what they expect in advance will be needed. Further, within any of the approved software packages, it is very easy to allow the use of defaults that are too conservative: generic windows, losses and gains

attributed to ductwork, and similar features that increase the stated design loads. This is especially true for the most efficient houses, that often use building components and levels of insulation that are so efficient that they are not recognised by the Manual J tables. In many cases, to follow the procedure properly, users must understand these limitations and override the software's default values, but there is little or no guidance to suggest that this is necessary. Even then, when the user has a result, they will still size the equipment even larger 'just in case'. In the end, absent requirements by incentive programs that include a review of the design process (which is rare), many (or perhaps most) residential contractors do not bother with the calculations because they conclude it gives them the answer they expect. All this results in oversizing equipment, which is not bad if it is within the guidelines but can be so extreme as to impact the operating efficiency seriously. It also makes the sizing procedures somewhat irrelevant if they are based on faulty load calculations.

The updated/proposed edition of Manual S is a significant improvement, but it is rather complex to understand and put into practice, which may be a large challenge for users who already have trouble understanding the simpler existing procedures. The biggest limitation on its use in the near term is that the methods available for two-speed and variable-speed systems also require knowing the total and/or latent capacities of the equipment at the lowest operating speed. Engineering data on low-speed capacity is rarely available for variable speed systems, which would make those pathways impossible to use until such data is regularly available. Also, the simplified approach for variable-speed has a limitation of high-speed total cooling capacity at 130% of the design cooling load, so it cannot account for lower-speed cooling operation and will be impossible to use in cases where the design heating load is significantly larger than the design cooling load. The other options require information about low-speed capacity.

Table 4.2.3-1. New edition of Manual S (preliminary) sizing condition summary for 2-speed and variable heat pumps

Condition:	Stage / speed	2-speed heat pumps		Variable-speed heat pumps		
		Normal	Dry ¹	Simplified	Advanced	Advanced/Dry ¹
Total cooling minimum	<i>High stage or full speed</i>	total capacity ² ≥90% of total load ³		total capacity ≥90% of total load		
Sensible cooling minimum		sensible capacity ≥90% of sensible load				
Latent cooling minimum		latent capacity ≥100% of latent load		latent capacity ≥100% of latent load		
Total cooling maximum		total capacity ≤125% of total load		total capacity ≤130% of total load	n/a	
Total cooling	<i>Low stage or min speed</i>	min speed capacity ≤80% of total load	min speed capacity ≤115% of total load			min speed capacity ≤80% of total load
Latent cooling					min speed latent capacity ≥100% of latent	
Heating minimum	<i>High stage or full speed</i>			same as advanced OR use supp. heat ⁴	total capacity ≥100% of heating load	
Heating maximum		heat capacity ≤120%; at 47°F ≤150%; of heat load				heat capacity at 47°F ≤150% of heat load
Heating	<i>Low stage or min speed</i>			same as advanced OR use supp. heat ⁴	min speed capacity ≤80% of heating load	
Supplemental heat		only what is needed for shortage (≤175% of the difference at design)		required only if heat capacity is < 100%; maximum of 5kW		

¹ Dry condition = design SHR > 95% - OR - active dehumidification is provided with design documentation

² "capacity" in all cases is at design condition except when specified

³ "load" (all cases) refers to cooling total, cooling sensible, cooling latent, or heating design load as referenced, *at the cooling or heating design condition*

⁴ If a variable-speed heat pump meets full heating load using simplified path it must also meet min-speed capacity limit; if not, the min speed limit is waived

The updated/proposed edition of Manual S is a significant improvement, but it is rather complex to understand and put into practice, which may be a large challenge for users who already have trouble understanding the simpler existing procedures. The biggest limitation on its use in the near term is that the methods available for two-speed and variable-speed systems also require knowing the total and/or latent capacities of the equipment at the lowest operating speed. Engineering data on low-speed capacity is rarely available for variable speed systems, which would make those pathways impossible to use until such data is regularly available. Also, the simplified approach for variable-speed has a limitation of high-speed total cooling capacity at 130% of the design cooling load, so it cannot account for lower-speed cooling operation and will be impossible to use in cases where the design heating load is significantly larger than the design cooling load. The other options require information about low-speed capacity.

4.2.3.2 The Northeast Energy Efficiency Partnership (NEEP) sizing and installation guidance

NEEP is a non-profit regional organisation in the U.S. that promotes energy efficiency and decarbonisation/electrification. In 2017 and 2018, with support from the US Department of Energy they developed two downloadable guides to assist designers and contractors in sizing, selecting, and installing air-source heat pumps for residential homes in cold climates. They can be downloaded here neep.org/ashpinstallerresources, and there are companion videos on the same web page.

The guides are not detailed design procedures, but each is more of an overview that covers at a fairly high level the things that residential HVAC professionals should pay attention to what to look out for along the way. It points them to the full design procedures (Manual J and S) for details but focuses on how to choose appropriate applications based on the house characteristics and client needs: designing a smaller system to strategically displace as much existing heat as possible; full heating replacement for a house; individual zone; and new construction or gut renovation. Once an approach is chosen, there is a page to guide users on the steps appropriate to further refine that application and explain possible risks to watch out for.

There are numerous other regional and local guides that are published and promoted by utility companies, state (provincial) agencies, or regional groups, but not sanctioned by government or required by regulation. The NEEP guides are one example of this type of resource that is well known and used widely.

4.2.4 ISO 13153:2012 and Japanese design guidelines for low energy housing with validated effectiveness

4.2.4.1 Short history of LEHVE and ISO 13153

In 2005, 'Design Guidelines for Low Energy Housing with Validated Effectiveness' (LEHVE) was developed based on the outputs from 4-year (2001-2004) national R&D project by national research institutes including Building Research Institute (BRI, 2013). The R&D project was funded by the Ministry of Land, Infrastructure, Transport and Tourism (MLIT) (IBECs, 2024).

Before the project, the effectiveness of a building enclosure on energy-saving was mainly focused on practice and in the national building energy standard, which was not mandatory. It was partly because there was a lack of quantitative technical information on how much energy can be saved by choosing energy-efficient equipment for space heating, and the gain of such

kind of knowledge was the main objective of the project. To tackle this issue, various experiments and monitorings were conducted to validate the effectiveness of major kinds of promising technology and equipment for residential buildings. Heat pump system had been one of the promising technologies dealt with in the project. Some experiments and monitorings are reviewed in Chapter 2 of this report (Section 2.4.3). There are three LEHVEs for three different climatic conditions, namely mild climate, cold climate, and hot humid climate. Only the LEHVE for hot humid climate was translated into English and is publicly available (Building Research Institute, 2010). The theories and experimental methods used for LEHVEs were further developed and finally have been utilised for web-based programs to calculate primary energy use for Japanese Building Energy Conservation Standard (BECS) (Building Research Institute/National Institute for Land and Infrastructure Management, 2013). The contents of the LEHVE and requirements for core quantitative information in the design guidelines for building design practitioners was standardised as ISO 13153:2013 'Framework of the design process for energy-saving single-family residential and small commercial buildings (ISO, 2012; Sawachi, 2013). LEHVE design guidelines have been presented at seminars. Over 24,000 practitioners have attended the seminars organised by an institute engaged in dissemination of energy saving technologies as of January 2024 (IBECs, 2024). More importantly, as mentioned before, technical knowledge for developing LEHVE has been utilised also for the BECS, in which not only documenting design but also online programs are provided for applicants, who are going to get certifications for various incentives and will try to get building permits after April 2025. The BECS will be mandatory after April 2025, even for detached houses newly built.

4.2.4.2 Core structure of information provided by LEHVE

Table 4.2.4-1 and Table 4.2.4-2 show the framework of design guidelines, by which LEHVEs are made and prescribed in ISO 13153 (ISO - International Organization for Standardization, 2012). Energy use comprises six uses for space cooling, ventilation (outdoor intake), domestic hot water, lighting, consumer electronics and other uses. There is no heating because this table is for houses in a hot humid climate, but there is, of course, space heating in cold and mild climate versions. Four-member family and a model building are assumed for energy calculation. The reference total annual primary energy use is 66.6 GJ/annum for houses with a ducted ventilation system. It takes time to understand Table 4.2.4-1, but it covers all technologies recommended to be considered in the design process with quantitative information on how much energy can be saved by applying each technology and each specification. For reducing cooling energy, three elemental technologies, namely 1) wind utilisation to dissipate internal heat (natural ventilation), 2) solar shading for roof and openings, and 3) cooling system (room air conditioners/fans), are highlighted, because it was the conclusion that influences of other elemental technologies were not clear when the guidelines were developed. An energy efficient cooling system can be designed not only for energy efficient air conditioners but also for ceiling fans. However, only information dealt with in the guidelines for air conditioners and heat pump water heaters shall be reviewed.

Table 4.2.4-1. Table of energy consumption ratios for different levels of each elemental technology for energy-saving (detached house in hot humid climate) with red ellipses showing selections of levels.

Use	Reference energy consumption	Elemental technology*	Evaluation index/method	Energy consumption ratio (reference consumption is 1.0)				
				Level 0	Level 1	Level 2	Level 3	Level 4
Cooling	10.3 GJ	Wind utilization/control (3.1)	Methods (1) Opening area on cross ventilation route a: small, b: large (2) Opening area according to prevailing wind direction (3) High window a: small, b: large	1.0	0.96	0.91	0.88	
			Location 1 Wind speed 1m/s or more	<input type="checkbox"/> Method not introduced	<input checked="" type="checkbox"/> (1) a, (3) a	<input type="checkbox"/> (1) b, (3) b	—	
			Location 2 Wind speed 1m/s or less	<input type="checkbox"/> Method not introduced <input type="checkbox"/> (1) a, (3) a	<input type="checkbox"/> (1) a + (2), (3) a + (2) <input type="checkbox"/> (1) b, (3) b	<input type="checkbox"/> (1) b + (2) <input type="checkbox"/> (3) b + (2)	—	
			Wind speed 1 - 2m/s or less	<input type="checkbox"/> Method not introduced	—	<input type="checkbox"/> (1) a, (3) a <input type="checkbox"/> (1) a + (2), (3) a + (2)	<input type="checkbox"/> (1) b, (3) b <input type="checkbox"/> (1) b + (2), (3) b + (2)	
			Wind speed 2m/s or more	<input type="checkbox"/> Method not introduced	—	<input type="checkbox"/> (1) a, (3) a	<input type="checkbox"/> (1) a + (2), (3) a + (2) <input type="checkbox"/> (1) b, (3) b <input type="checkbox"/> (1) b + (2), (3) b + (2)	
		Solar shading method (4.2)	Methods (1) Outside shading device (2) Envelope a: cavity ventilation, b: insulation, c: reflection	1.0	0.9	0.8	0.75	0.7
		Location 1 (1) Class 0	<input type="checkbox"/> No measures	<input type="checkbox"/> (2) a: Cavity ventilation	—	<input type="checkbox"/> (2) b: Insulation	<input type="checkbox"/> (2) c: Reflection	
		(1) Class 1	<input type="checkbox"/> No measures	<input type="checkbox"/> (2) a: Cavity ventilation	—	—	<input type="checkbox"/> (2) b: Insulation <input type="checkbox"/> (2) c: Reflection	
		(1) Class 3	—	<input type="checkbox"/> No measures	<input checked="" type="checkbox"/> (2) a: Cavity ventilation	—	<input type="checkbox"/> (2) b: Insulation <input type="checkbox"/> (2) c: Reflection	
		Location 2 (1) Class 0	<input type="checkbox"/> No measures	<input type="checkbox"/> (2) a: Cavity ventilation	—	<input type="checkbox"/> (2) b: Insulation <input type="checkbox"/> (2) c: Reflection	—	
(1) Class 1	<input type="checkbox"/> No measures	<input type="checkbox"/> (2) a: Cavity ventilation	—	<input type="checkbox"/> (2) b: Insulation <input type="checkbox"/> (2) c: Reflection	<input type="checkbox"/> (2) c: Reflection			
(1) Class 2	—	<input type="checkbox"/> No measures	<input type="checkbox"/> (2) a: Cavity ventilation	—	<input type="checkbox"/> (2) b: Insulation <input type="checkbox"/> (2) c: Reflection			
(1) Class 3	<input type="checkbox"/> No measures	<input type="checkbox"/> (2) a: Cavity ventilation	<input type="checkbox"/> (2) b: Insulation <input type="checkbox"/> (2) c: Reflection	—	—			
Location 3 (1) Class 0	<input type="checkbox"/> No measures	<input type="checkbox"/> (2) a: Cavity ventilation	<input type="checkbox"/> (2) b: Insulation <input type="checkbox"/> (2) c: Reflection	—	—			
(1) Class 1	<input type="checkbox"/> No measures	<input type="checkbox"/> (2) a: Cavity ventilation	—	<input type="checkbox"/> (2) b: Insulation <input type="checkbox"/> (2) c: Reflection	—			
(1) Class 2	<input type="checkbox"/> No measures	<input type="checkbox"/> (2) a: Cavity ventilation	—	—	<input type="checkbox"/> (2) b: Insulation <input type="checkbox"/> (2) c: Reflection			
(1) Class 3	<input type="checkbox"/> No measures	<input type="checkbox"/> (2) a: Cavity ventilation	<input type="checkbox"/> (2) a: Cavity ventilation	—	—	<input type="checkbox"/> (2) b: Insulation <input type="checkbox"/> (2) c: Reflection		
Cooling system planning (5.1)	Methods (1) High-efficiency air conditioner (COP) (2) Use of fan/ceiling fan	1.0	0.9	0.8	0.75	0.65		
<input type="checkbox"/> COP3	<input type="checkbox"/> COP4	<input type="checkbox"/> COP3 + (2) <input type="checkbox"/> COP5	<input type="checkbox"/> COP4 + (2)	<input checked="" type="checkbox"/> COP5 + (2)				
Ventilation	3.1 GJ	Duct ventilation (1) Duct pressure loss decrease (2) High-efficiency device	1.0	0.7	0.5			
	2.8 GJ	Through-the-wall ventilation (1) Optimizing the combination of fan and outside air unit	1.0	0.8				
Domestic hot water	13.8 GJ	Solar water heating (3.5)	Methods (1) Heat collection area a: small, b: medium, c: large (2) Connection to auxiliary heat source a: none, b: three-way valve, c: solar connection unit (3) Energy-efficient circulating pump	1.0	0.9	0.7	0.5	0.3
	Domestic hot water system planning (5.4)	Methods (2)-1 Latest heat recovery water heater (2)-2 0.3-HP water heater (3) Piping method/hot water saving tools	1.0	0.9	0.8	—	0.6	
Lighting	13.6 GJ	Daylight utilization (3.2)	Conditions for daylighting (1) Bi-directional daylighting for living/dining rooms (2) Bi-directional daylighting for living/dining/senior's rooms (3) Bi-directional daylighting for living/dining/senior's rooms + mono-directional daylighting for non-habitable room	1.0	0.97 - 0.98	0.95	0.9	
		Lighting system planning (5.5)	Methods (1) Method using device (2) Method using operation and control (3) Method using design	1.0	0.85	0.8	0.7	
Consumer electronics	21.4 GJ	Introduction of high-efficiency consumer electronics (5.6)	Guidelines for the year device was made	1.0	0.8	0.6		
Other uses (cooking)	4.4 GJ			1.0				
				<input checked="" type="checkbox"/> Cooking device				
Total	66.6 GJ 66.3 GJ							
Electricity		Photovoltaic power generation (3.3)	(Naha) Solar cell capacity	No reduction <input checked="" type="checkbox"/> Not to be introduced	33.7 GJ reduction	45.0 GJ reduction		
					<input type="checkbox"/> Approx. 3 kW	<input type="checkbox"/> Approx. 4 kW		

* Numbers in parentheses under each elemental technology indicate which section of Chapter 3, 4 or 5 describes it.

Note: by numbers and symbols (e.g., (1)a, (2)) in the table, specification of each LEVEL of elemental technologies can be identified in the main body of the LEHVE (Building Research Institute, 2010).

Table 4.2.4-2 Energy consumption calculation table by using energy consumption ratios of chosen levels of elemental technologies (Building Research Institute, 2010)

Table 4.2.4-2. An example of energy consumption calculation, where elemental technologies and their levels are selected as shown by red ellipses in Table 4.2.4-1 (Building Research Institute, 2010)

Use	Calculation formulas	Design value	Reference value	Reduction rate
Cooling	$10.3 \times (\text{ } \times \text{ } \times \text{ })$	GJ	10.3GJ	
Ventilation	$3.1 \times \text{ } (2.8)$	GJ	3.1GJ (2.8GJ)	
Domestic hot water	$13.8 \times \text{ } (Solar\ water\ heating\ or\ Domestic\ hot\ water\ system\ planning)$	GJ	13.8GJ	
Lighting	$13.6 \times (\text{ } \times \text{ })$	GJ	13.6GJ	
Consumer electronics	$21.4 \times \text{ } $	GJ	21.4GJ	
Other uses (cooking)	$4.4 \times \text{ } $	GJ	4.4GJ	
Subtotal		GJ	66.6GJ (66.3GJ)	
Electricity (reduction amount)	Power generation with solar cell <input type="checkbox"/> 0.0 GJ <input type="checkbox"/> 33.7 GJ <input type="checkbox"/> 45.0 GJ	▲ GJ		
Total		GJ	66.6GJ (66.3GJ)	

Table 4.2.4-3. An example of energy consumption calculation, where elemental technologies and their levels are selected as shown by red ellipses in Table 4.2.4-1

Use	Calculation formulas	Design value	Reference value	Reduction rate
Cooling	$10.3 \times (0.96 \times 0.8 \times 0.65)$	5.14GJ	10.3GJ	50.1%
Ventilation	3.1×0.5	1.55GJ	3.1GJ	50.0%
Domestic hot water	$13.8 \times 0.5 (Solar\ water\ heating\ or\ Domestic\ hot\ water\ system\ planning)$	6.9GJ	13.8GJ	50.0%
Lighting	$13.6 \times (0.95 \times 0.7)$	9.04GJ	13.6GJ	33.5%
Consumer electronics	21.4×0.6	12.84GJ	21.4GJ	40.0%
Other uses (cooking)	4.4×1.0	4.4GJ	4.4GJ	0.0%
Subtotal		39.9GJ	66.6GJ	40.1%
Electricity (reduction amount)	Power generation with solar cell <input checked="" type="checkbox"/> 0.0 GJ <input type="checkbox"/> 33.7 GJ <input type="checkbox"/> 45.0 GJ	▲ 0.0GJ		
Total		39.9GJ	66.6GJ	40.1%

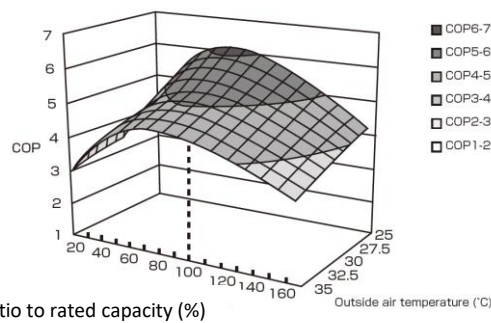

Figure 4.2.4-1. Relationship between outdoor temperature, partial load ratio and COP for cooling (Building Research Institute, 2010)

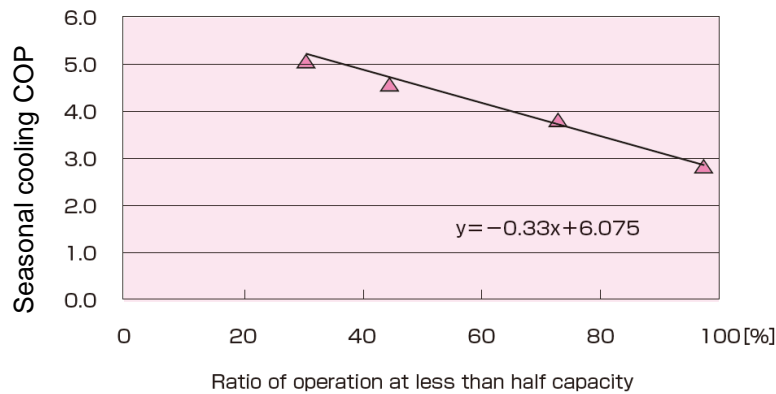

Figure 4.2.4-2. Effect of ratio of low partial load operation on seasonal average cooling COP (Building Research Institute, 2010)

Table 4.2.4-4. Recommended maximum cooling capacity (kW) as a guideline for selecting air conditioner for different levels of solar shading conditions represented by M value, which is defined in the guidelines (Building Research Institute, 2010)

Level of solar shading method	M value Summer solar gain coefficient that factors in the effect of adjacent buildings		6 <i>tatami</i> mats (10 m ²)	8 <i>tatami</i> mats (13 m ²)	10 <i>tatami</i> mats (16 m ²)	14 <i>tatami</i> mats (22 m ²)
	Insulation or vented cavity	Solar reflection				
Level 0	Exceeds 0.135	Exceeds 0.150	3.7	4.9	6.1	8.6
Level 1	0.135	0.150	3.1	4.1	5.1	7.1
Level 2	0.10	0.125	2.6	3.4	4.3	6.0
Level 3	0.08	0.115	2.1	2.8	3.5	5.3
Level 4	0.065~0.04	0.105~0.092	1.9~1.6	2.6~2.1	3.2~2.7	4.9~4.0

4.2.4.3 Contents for room air conditioners in LEHVE for hot humid climate

According to the guidelines, 'Level 0' for the cooling system is accomplished by using room air conditioners with the rated COP of 3.0, and 'Level 2' is accomplished by using those with the rated COP of 5.0. The latter condition (design) is evaluated to save cooling energy by approximately 20%, that is equal to 2 GJ/annum.

The influence of partial load ratio on the energy efficiency of room air conditioners is introduced by Figure 4.2.4-1 and Figure 4.2.4-2. Because appropriate capacity of room air conditioner for a room is important, Table 4.2.4-3 is provided to show appropriate maximum capacity of room air conditioners for different levels of solar shading (building enclosure and distance from adjacent buildings) and area of the room.

4.2.4.4 Contents for heat pump water heaters in LEHVE

Before introducing the contents for heat pump water heaters in LEHVE, an overall recommended strategy to save energy for domestic hot water (DHW) is introduced as follows. There are two elemental technologies to save energy for DHW, namely 1) solar water heating and 2)

DHW system planning (i.e., choosing energy efficient equipment for DHW and design), as shown in Table 4.2.4-4.

Energy saving for each specification (combination of methods in Table 4.2.4-4) is quantified, as shown in Table 4.2.4-5. In Table 4.2.4-6, 'electric water heater with a natural refrigerant heat pump (CO₂ HP)' is evaluated as a 40% reduction rate if it is used by 'energy-efficient mode'. CO₂ HPs in the Japanese market are standardised by JIS C 9220 'Residential heat pump water heaters' (JSA Group, 2018). Their common configuration and secondary energy flow can be represented by Figure 4.2.4-3.

Table 4.2.4-5. Method alternatives for energy saving DHW systems (BRI Japan, 2010)

Method	Description of method	Energy saving effect (Domestic hot water energy reduction rate)
Method 1	Using solar heat (adopting solar water heater or solar system)	
Method 2	Using high-efficiency water heater Latent heat recovery gas/oil water heater Electric water heater with a natural refrigerant heat pump (CO ₂ HP)* Only when boiling mode serves as "energy-efficient" mode	Approx. 15%
		Approx. 35% (Zone V) Approx. 40% (Zone VI)
Method 3	Considering energy-efficient design/construction for each component of domestic hot water system (thermal insulation of piping/bathtub, hot water saving devices, etc.)	Approx. 10%

Note: Energy saving effect by using solar heat is between 10 to 70%, which is described in the chapter on solar water heating in LEHVE guidelines.

The most important message to practitioners for CO₂ HPs is that they have approximately 40% or more energy-saving potential as described in Table 4.2.4-5. But it is indispensable for users to use them with 'energy-efficient mode' by selecting appropriate modes at their controllers. If they selected 'maximum heat storage only during night', energy use would increase 10% or more compared with conventional instant gas boilers, as shown in Figure 4.2.4-4.

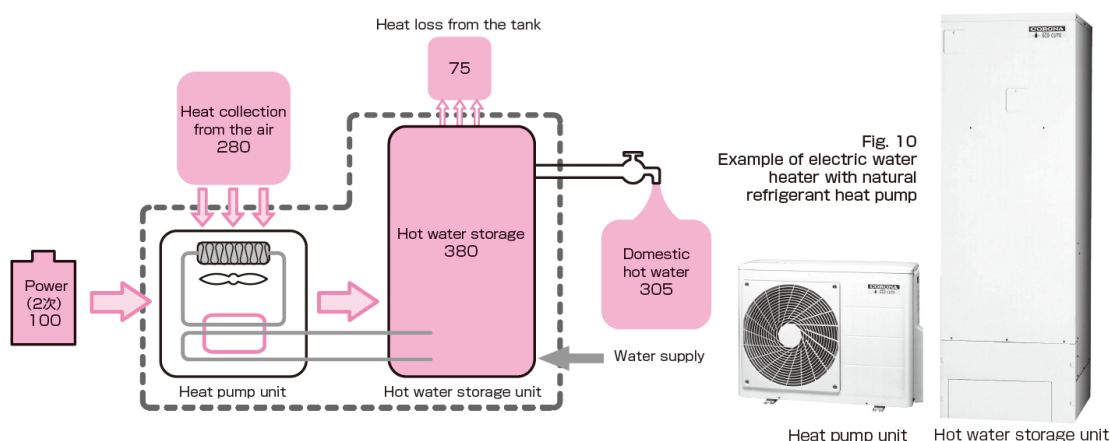

Figure 4.2.4-3. Secondary energy flow (numbers in normalised energy unit) of electric water heater with natural refrigerant heat pump (estimated annual average based on 2005 model of 'Energy-efficient mode' by manufacturer A) (BRI Japan, 2010)

Table 4.2.4-6. Target levels for DHW system planning and how to achieve them by combinations of method alternatives (Building Research Institute, 2010)

Target level	Energy saving effect (Domestic hot water energy reduction rate)	Application of method
Level -1	Increase of 10% or more	Method 2 (CO ₂ HP used for "Maximum boiling mode" and "Maximum late-night only mode")
Level 0	0	Uses a conventional domestic hot water system device only and does not apply any energy saving methods.
		Method 2 (CO ₂ HP used for "Medium late-night only mode")
Level 1	10% or more	Method 2 (latent heat recovery gas/oil water heater)
		Method 2 (CO ₂ HP used for "Medium boiling mode (Zone V)")
		Method 3
Level 2	20% or more	Method 2 (latent heat recovery gas/oil water heater) + Method 3
		Method 2 (CO ₂ HP used for "Medium boiling mode" (Zone VI))
Level 3	30% or more	Method 2 (CO ₂ HP used for "Energy efficient mode" (Zone V))
Level 4	40% or more	Method 1
		Method 2 (CO ₂ HP used for "Energy-efficient mode" (Zone VI))
		Method 2 (CO ₂ HP used for "energy-efficient mode") + Method 3

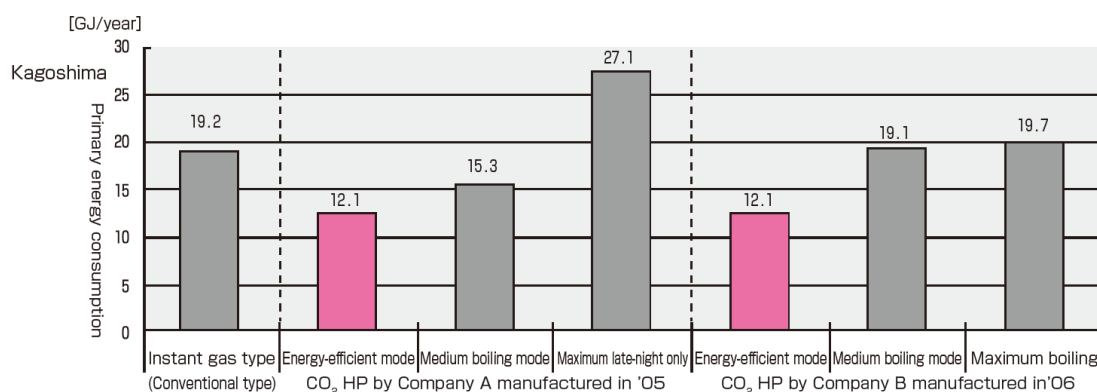

Figure 4.2.4-4. Changes in annual primary energy consumption using CO₂ HPs at various modes

4.3 Perspectives of developing design guidelines for heat pump systems in Annex 88

The characteristics of existing guidelines presented in this chapter are summarised in Table 4.3.1-1. It reveals significant gaps in the ages of guidelines presented, highlighting a divergence of approximately 10 to 15 years between certain recommendations. This highlights the ongoing evolution of sizing guidelines within the industry. It emphasises the necessity for regular updates to align with technological advancements and methodological refinements. Such updates are crucial for ensuring that sizing practices remain effective in accurately determining the

capacity of heat pump (HP) systems relative to actual maximum loads. This continuous evolution not only reflects industry progress but also reinforces the importance of adapting guidelines to optimise system efficiency and energy conservation efforts.

Efficient operation under varying load conditions is pivotal for HP systems in maintaining energy efficiency. To address low partial load conditions effectively, several countermeasures can be employed. These include adopting HP models designed for higher efficiency under partial loads, integrating multiple staged HP systems for larger total loads, and utilising heat/cold thermal storage solutions. By implementing these strategies, energy wastage during periods of reduced demand can be minimised, enhancing overall system performance. This approach not only optimises energy use but also aligns with sustainability objectives by reducing environmental impact through improved energy management practices.

Effective control of HP systems is essential for maximising their performance and energy efficiency. Clear and logically prescribed technical documentation detailing control strategies is required. Quantitative examples play a crucial role in illustrating the impact of these controls on system efficiency. By demonstrating the energy use dynamics and efficiency variations of HP systems under different operational scenarios, these examples provide actionable insights for HVAC designers and stakeholders. They facilitate informed decision-making in system design and optimisation, ensuring that HP systems operate at peak efficiency while meeting performance criteria outlined in technical standards and guidelines.

Identifying targeted HP system types early in guideline development is foundational. Hydronic HP systems for space heating and domestic hot water, alongside air conditioners like variable refrigerant flow systems, are prioritised because of their widespread applicability and energy efficiency potential. Manufacturers play a pivotal role in supporting HVAC designers with consistent, concrete, and quantitative technical information. This information is crucial for navigating the complexities of integrating HP systems into buildings. Clear, step-by-step procedures provided by manufacturers enable designers to make informed decisions that optimise system performance and energy efficiency based on reliable data and industry best practices.

While comprehensive, the guideline under development in Subtask D acknowledges its limitations in covering all types of HP systems. Air-source heat pumps (ASHP) are the primary focus because of their extensive global application, whereas air-to-water systems dominate in European contexts. Proposals for including both air-to-air and air-to-water HP systems in Annex 88's design guidelines recognise their relevance across diverse geographical and climatic conditions. This inclusive approach ensures that the guidelines cater to a broad spectrum of HP applications, fostering standardised practices that promote energy efficiency and sustainability in HVAC systems worldwide.

The development and refinement of guidelines for HP systems are instrumental in advancing energy-efficient practices within the HVAC industry. By addressing sizing methodologies, efficiency considerations, control strategies, and including diverse HP system types, these guidelines pave the way for standardised approaches that enhance system performance while reducing environmental impact. As technologies continue to evolve and global energy demands grow, the ongoing adaptation and implementation of these guidelines will play a pivotal role in shaping the future of sustainable building practices and energy management strategies.

The structured approach provides a comprehensive overview of the topics outlined previously, ensuring each aspect is sufficiently explored within a coherent framework.

Representative monitoring results for those HP systems to be included to show exemplified monitoring data of HP systems to readers (need contribution by Subtask B2). With the

explanation of characteristics of current testing standards for HP systems, guidance on which metrics, based on which testing standards, should be highlighted should be included (need contribution by Subtask B1). Also, a reliable energy calculation method should be introduced and utilised to provide quantitative information on influences of design parameters on the system energy performance (need contribution by Subtask C). Finally, easily understood educational materials on how they can design energy efficient HP systems should be provided with the data based on the calculation methods. These materials should be tailored to specific segments: e.g., mechanical engineers designing large facilities will have a different level of knowledge, and need very different type of details, then residential HVAC contractors for single-family or larger multifamily housing; required concerns and knowledge vary with different climates, etc.

Table 4.3.1-1. Characteristics of current guidelines

Guideline	HP Type	Applications	Year	Note
EN 15450:2007	Air-to-air, air-to-water, water-to-water, water-to-air, geothermal water-to-air, geothermal water-to-water, geothermal refrigerant-to-water, geothermal refrigerant-to-refrigerant	Space heating, DHW	2007	Capacity less than 1 MW
VDI 4645:2023-04	Air-to-water	Space heating and DHW	2023	-
CSA SPE-17:23	Air-to-air, air-to-water, geothermal water-to-air, geothermal water-to-water, gas-fired HP	HVAC	2023	-
ACCA Manual J	Air to air and ground-source air-to-water	Heating and cooling building load calculation	2016	-
ACCA Manual S	Almost all types of residential HVAC equipment	To select appropriate heating and cooling equipment at design conditions.	2014 (new version 2023)	New version is recently published. It will better support heat pump space heating.
NEEP	Air source heat pumps - guidance	Residential homes are targeted. Air-to-air ductless and ducted	2017 and 2018	Not detailed. Pointing readers to Manual J and S by ACCA
ISO 13153:2012	Air-to-air, air-to-water	Space heating and cooling, DHW	2012	A framework of guidelines for energy efficient housing is prescribed.
LEHVE	Air-to-air, air-to-water	Space heating and cooling, DHW	Mild climate: 2005, 2015 (2 nd edition) Hot humid climate: 2010, 2012 (English edition) Cold climate: 2012	-
<p>Note that the scope of this list is limited to determining building loads (e.g., heating and cooling design and necessary operating conditions) and selecting appropriate equipment to meet those loads. In reality, whenever possible good design practice should include, or may be required to include further items that are outside the scope of this list. Integrated design that accounts for mechanical system and building enclosure design (for example, thermal properties of insulation and windows, comfort requirements) and other systems (for example, solar PV array) together with the heat pump(s) to better optimise the entire system and increase energy efficiency and indoor environmental quality as well as reduce capital cost. In addition, there may be further design requirements for heat pumps defined by (for example) indoor air quality and fire safety requirements in case of mass refrigerant leakage, or other similar statutory or best practice design guidelines.</p>				

4.4 References

- ACCA - Air Conditioning Contractors of America. (2016). Manual J Residential Load Calculation (8th Edn - Full).
- ACCA - Air Conditioning Contractors of America. (2023). Manual S - Residential Equipment Selection (3rd Edn, Version 1.01).
- BRI - Building Research Institute Incorporated Administrative Agency Japan. (2010). Design Guidelines for Low Energy Housing with Validated Effectiveness (LEHVE).
- BRI - Building Research Institute, Japan. (2010). Design Guidelines for Low Energy Housing with Validated Effectiveness: Hot Humid Region Edition, 397 pages <https://www.kenken.go.jp/english/contents/publications/paper/149/index.html>.
- BSI – British Standard Institution (2022). BS EN 14825:2022: Air conditioners, liquid chilling packages and heat pumps, with electrically driven compressors, for space heating and cooling, commercial and process cooling. Testing and rating at part load conditions and calculation of seasonal performance.
- BRI/NILIM -Building Research Institute/National Institute for Land and Infrastructure Management. (2013). Technical Information regarding energy consumption performance of buildings, since 2013, <https://www.kenken.go.jp/becc/index.html>.
- Canadians for Properly Built Homes (2024) <https://canadiansforproperlybuilt homes.com/>
- CEN - Comité Européen de Normalisation. (2014). EN 12828:2012+A1:2014 Heating systems in buildings. Design for water-based heating systems.
- CEN - Comité Européen de Normalisation. (2017a). EN 12831-1:2017 Energy performance of buildings. Method for calculation of the design heat load Space heating load, Module M3-3.
- CEN - Comité Européen de Normalisation. (2017b). EN 12831-3:2017 Energy performance of buildings. Method for calculation of the design heat load Domestic hot water systems heat load and characterisation of needs, Module M8-2, M8-3.
- CEN - Comité Européen de Normalisation. (2017c). EN ISO 52016-1:2017 Energy performance of buildings. Energy needs for heating and cooling, internal temperatures and sensible and latent heat loads Calculation procedures.
- CEN - Comité Européen de Normalisation. (2017d). CEN/TC 228/WG 4 - Calculation methods and system performance and evaluation.
- CEN - Comité Européen de Normalisation. (2018). EN 14511-2:2018 - Test methods and standards for air conditioners, liquid chilling packages and heat pumps.
- CEN - Comité Européen de Normalisation. (2020). EN 12102-2:2020 Air conditioners, liquid chilling packages, heat pumps, process chillers and dehumidifiers with electrically driven compressors - Determination of the sound power level - Part 2: Heat pump water heaters.
- CEN - Comité Européen de Normalisation. (2022). EN 16147:2017+A1:2022 Heat pumps with electrically driven compressors. Testing, performance rating and requirements for marking of domestic hot water units.
- CSA - Canadian Standards Association Group. (2023). CSA SPE-17:23 HVAC guide for Part 9 homes.
- CSA Group (2024a). Canadian Electrical Code Products, <https://www.csagroup.org/store/canadian-electrical-code-products/>
- CSA Group (2024b). <https://www.csagroup.org/store/>, Tel: 1-800-463-6727, 178 Rexdale Blvd., Toronto, ON, M9W 1R3.
- Danish Energy Agency, Danish building regulations - codes (BR23). (2023).
- Energy StepCode, (2018). How the BC Energy Step Code works, <https://energystepcode.ca/how-it-works/>
- Energy StepCode, (2021). Zero Carbon Step Code, <https://energystepcode.ca/zero-carbon/>

- Government of Canada (2020a). National Building Code of Canada 2020, <https://nrc.canada.ca/en/certifications-evaluations-standards/codes-canada/codes-canada-publications/national-building-code-canada-2020>
- Government of Canada (2020b). National Energy Code of Canada for Buildings 2020, <https://nrc.canada.ca/en/certifications-evaluations-standards/codes-canada/codes-canada-publications/national-energy-code-canada-buildings-2020>
- Government of Canada (2024a). Local Energy Efficiency Partnerships (LEEP), <https://natural-resources.canada.ca/energy-efficiency/homes/local-energy-efficiency-partnerships-leep/17338>
- Government of Canada (2024b). Toolkit for air source heat pump sizing and selection, <https://natural-resources.canada.ca/maps-tools-and-publications/tools/modelling-tools/toolkit-for-air-source-heat-pump-sizing-and-selection/23558>
- IBECs - The Housing and Building SDGs Promotion Center, Institute for Built Environment and Carbon Neutral for SDGs. (2024). Home page for LEHVE design guidelines, Design guidelines for self-reliant and recycling-oriented housing. <https://www.jjj-design.org/jjj/jjj-guideline.html>
- ISO - International Organization for Standardization. (2012). ISO 13153:2012 Framework of the design process for energy-saving single-family residential and small commercial buildings.
- JSA Group - Japanese Standards Association Group. (2018). JIS C 9220:2018 Residential heat pump water heaters.
- Mowris, R., & Jones, E. (2008, August 17-22). Peak Demand and Energy Savings from Properly Sized and Matched Air Conditioners the 14th biennial ACEEE conference on Energy Efficiency in Buildings, Asilomar Conference Center, Pacific Grove CA.
- NEEP - Northeast Energy Efficiency Partnerships. (2020a). Guide to Installing Air-Source Heat Pumps in Cold Climates.
- NEEP - Northeast Energy Efficiency Partnerships. (2020b). Guide To Sizing & Selecting Air-Source Heat Pumps in Cold Climates.
- Red Seal Program (2024). Refrigeration and Air Conditioning Mechanic, <https://www.red-seal.ca/eng/trades/r.1cm.shtml>
- Sawachi, T. (2013). Towards the ultra-efficient home – ISO standard supports the development of energy efficient homes. ISO Focus+, 4(1), 19-22.
- VDI - Verein Deutscher Ingenieure. (2023). VDI 4645 Berichtigung:2023-07 Heating systems with heat pumps in single and multi-family houses - Planning, construction, operation.